



CHRYSLER 45RFE

[PREVIOUS](#)
[MENU](#)

INDEX

GO TO PAGE

CLUTCH APPLICATION CHART	4
SOLENOID ON/OFF CHART	5
CASE CONNECTOR AND TCM PIN CAVITY IDENTIFICATION	11
WIRING SCHEMATIC	13
CONTROL RELAY AND FUSE LOCATIONS	14
TRS/SOLENOID BODY TESTS	18
OBDII DIAGNOSTIC TROUBLE CODE IDENTIFICATION	20
OIL PASSAGE IDENTIFICATION	22
LINE PRESSURE TESTING	30
GENERAL OPERATION INFORMATION	31
TRANSMISSION DISASSEMBLY PROCEDURE	32
COMPONENT REBUILD PROCESS	
TRANSMISSION CASE ASSEMBLY	42
LOW/REVERSE CLUTCH HOUSING ASSEMBLY	44
2-4 CLUTCH RETAINER ASSEMBLY	50
GEAR TRAIN COMPONENTS	53
INPUT CLUTCH HOUSING ASSEMBLY	54
INPUT CLUTCH HOUSING SNAP RING IDENTIFICATION	56
OIL PUMP ASSEMBLY INCLUDING VALVES	65
VALVE BODY ASSEMBLY	73
TRANSMISSION FINAL ASSEMBLY	83
CHECKING FRONT AND REAR END-PLAY	89
AIR PRESSURE TESTS	91
END-PLAY SPECIFICATIONS	96
FLUID SPECIFICATIONS	96
TORQUE SPECIFICATIONS AND BOLT IDENTIFICATION	97
EXPLODED ILLUSTRATIONS OF INTERNAL PARTS	98
THRUST BEARING CHART	108
SPECIAL TOOLS	109
IDENTIFICATION TAG LOCATION	112

CAUTION: ATSG service manuals are intended for use by professional, qualified technicians. Attempting repairs or service without the proper training, tools and equipment could cause injury to you or others and damage to the vehicle that may cause it not to operate properly.

**AUTOMATIC TRANSMISSION SERVICE GROUP
9200 S. DADELAND BLVD. SUITE 720
MIAMI, FLORIDA 33156
(305) 670-4161**

Copyright © ATSG 1999

September, 1999



INTRODUCTION

CHRYSLER 45RFE

Beginning at the start of production for the 1999 model year Chrysler Corporation has introduced a brand new rear wheel drive transmission for the 99 Jeep Grand Cherokee with the 4.7L engine, and scheduled for the Ram Pick-up for the 2000 model year. This is the first completely new rear wheel drive automatic transmission from Chrysler in more than thirty years. The 45RFE designation tells us that this new unit has 4 forward speeds, a relative torque rating of 5, is for Rear drive vehicles and is Fully Electronic controlled. Refer to Figure 1.

No part of any ATSG publication may be reproduced, stored in any retrieval system or transmitted in any form or by any means, including but not limited to electronic, mechanical, photocopying, recording or otherwise, without *written* permission of Automatic Transmission Service Group. This includes all text illustrations, tables and charts.

The information and part numbers contained in this booklet have been carefully compiled from industry sources known for their reliability, but ATSG does not guarantee its accuracy.

Copyright © ATSG 1999

ROBERT D. CHERRNAY
TECHNICAL DIRECTOR

WAYNE COLONNA
TECHNICAL SUPERVISOR

PETER LUBAN
TECHNICAL CONSULTANT

ARSENIO RIVERA
TECHNICAL CONSULTANT

JERRY GOTT
TECHNICAL CONSULTANT

DALE ENGLAND
FIELD SERVICE CONSULTANT

JIM DIAL
TECHNICAL CONSULTANT

ED KRUSE
TECHNICAL CONSULTANT

GREGORY LIPNICK
TECHNICAL CONSULTANT

GERALD CAMPBELL
TECHNICAL CONSULTANT

DAVID CHALKER
TECHNICAL CONSULTANT

AUTOMATIC TRANSMISSION SERVICE GROUP
9200 S. DADELAND BLVD. SUITE 720
MIAMI, FLORIDA 33156
(305) 670-4161

JEEP GRAND CHEROKEE 45RFE TRANSMISSION
FOUND BEHIND 4.7L ENGINE FOR 1999

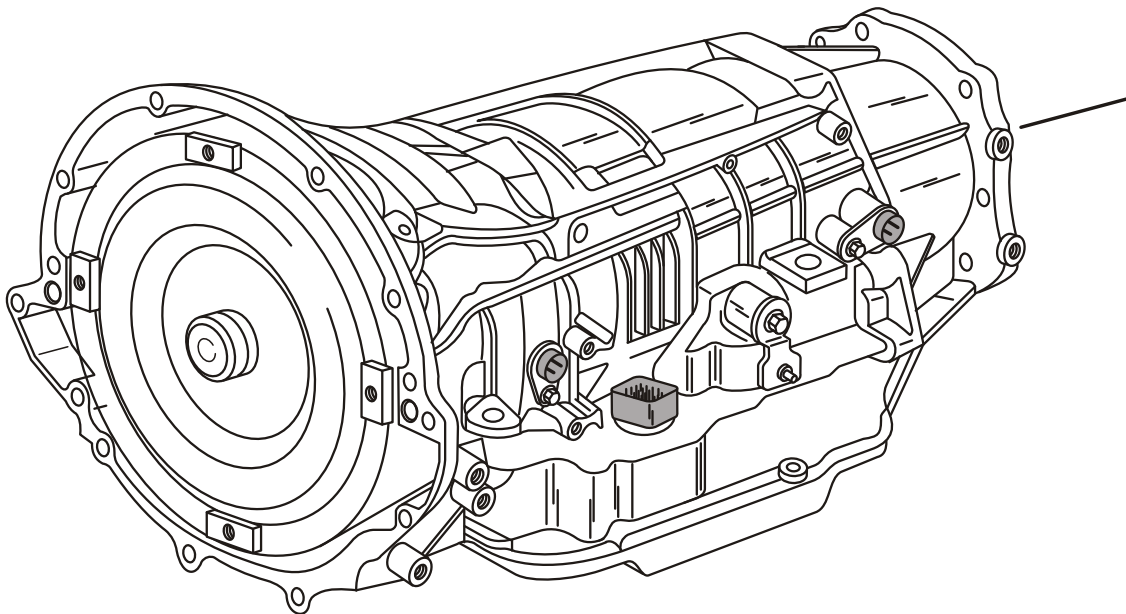

4 = Four Forward Speeds

5 = Relative Torque Capacity

R = Rear Wheel Drive

FE = Fully Electronic

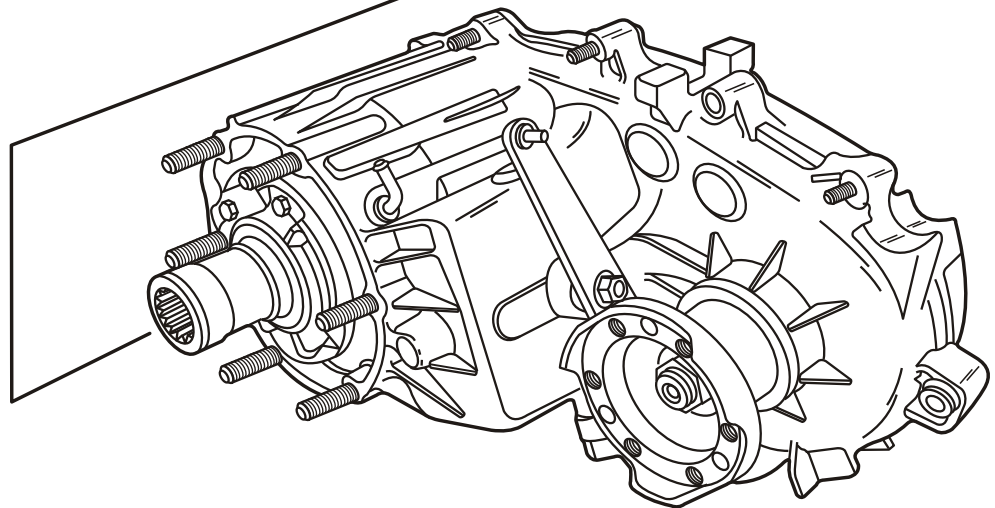

Copyright © 1999 ATSG

Figure 1

CLUTCH APPLICATION CHART

SELECTOR POSITION	LO/REV CLUTCH	UD CLUTCH	SECOND CLUTCH	OD CLUTCH	FOURTH CLUTCH	REVERSE CLUTCH	LOW OVERRUN CLUTCH	GEAR RATIO
PARK	ON							
REVERSE	ON					ON		3.00:1
NEUTRAL	ON							
OD-1ST	ON*	ON					HOLD	3.00:1
OD-2ND		ON	ON					1.67:1
2ND PRIME		ON			ON			1.50:1
OD-3RD		ON		ON				1.00:1
OD-4TH				ON	ON			0.75:1
OD-LIMP		ON		ON				1.00:1
(2)-1ST	ON*	ON					HOLD	3.00:1
(2)-2ND		ON	ON					1.67:1
(2)-LIMP		ON	ON					1.67:1
(1)-1ST	ON*	ON					HOLD	3.00:1

* L/R Clutch is on only with the output shaft speed below 150 RPM.

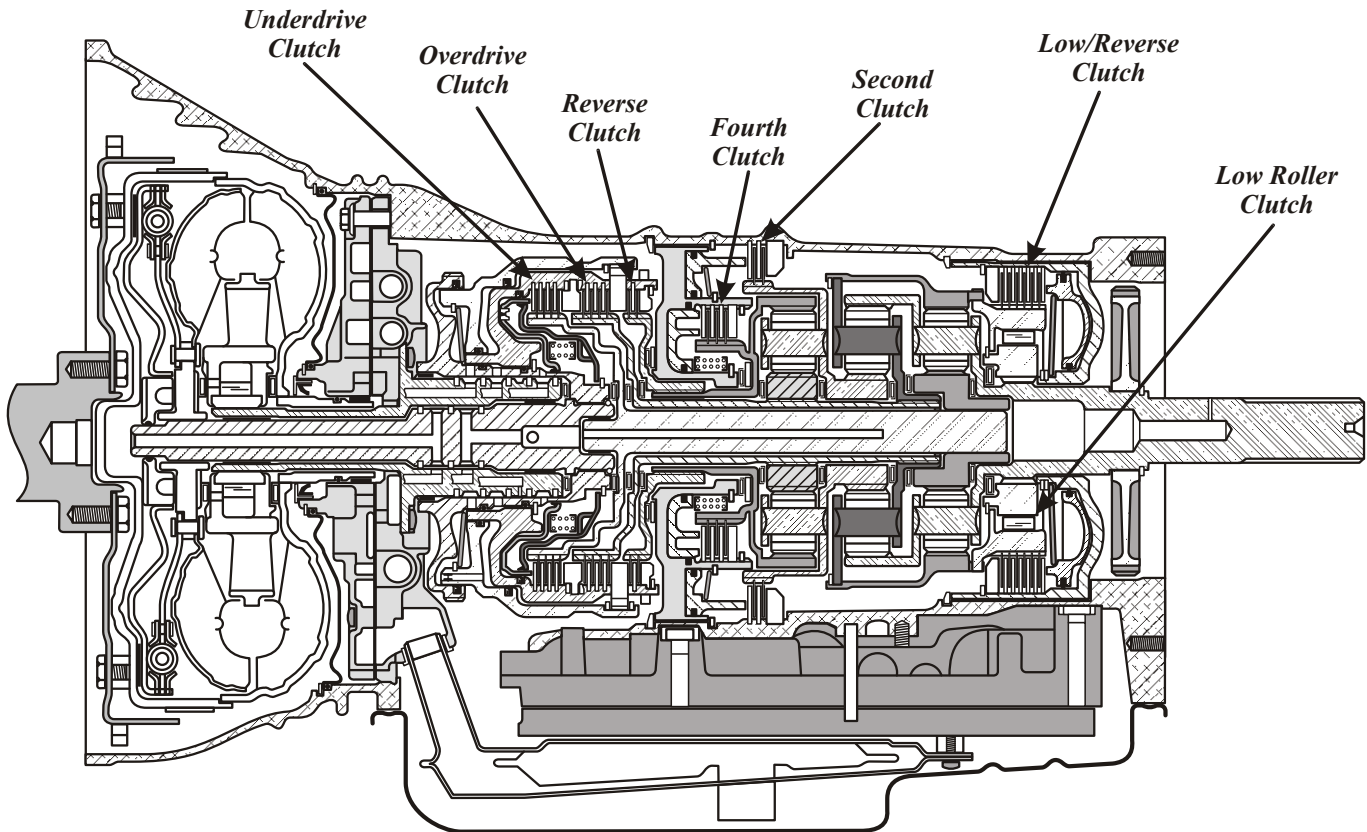

Copyright © 1999 ATSG

Figure 2



Technical Service Information

MECHANICAL OPERATION

The operation of the 45RFE is very similar to the Chrysler 41TE (A604) and 42LE (A606) transaxles that you are already familiar with. The 45RFE has no internal bands, but uses several different clutch assemblies instead. The Input Clutch Housing retains the underdrive clutch, overdrive clutch and the reverse clutch and is set up almost identical to the 41TE transaxle, except much larger. The 45RFE also contains separate holding clutches, such as the 2nd clutch, 4th clutch and the low/reverse clutch. This unit also uses one overrunning or freewheel device called the low overrun clutch.

To achieve its different gear ratios, the 45RFE applies different combinations of two clutch packs at a time, as shown in Figure 2. In Park and Neutral, only the low/reverse clutch is applied. Notice also that a unique characteristic of the 45RFE is its alternate 2nd gear ratio, or "2nd prime" as it is known. The 2nd prime is enabled only during kickdown shifts above certain speeds, that enhances vehicle performance by allowing for a higher gear ratio passing gear at highway speeds. Refer to the chart in Figure 2 for the clutches that are applied for each shift lever position.

Another feature of this unit is the three planetary gear sets, as shown in Figure 2, which is one more than you are used to seeing in a Chrysler unit. These planetary gear sets provide a deeper 1st and reverse ratio and does not need a separate overdrive unit. All gear ratios are also shown in the chart in Figure 2.

SOLENOID CHART							
	N.O.	N.C.	N.O.	N.O.	N.O.	N.C.	
SELECTOR POSITION	LR/CC SOLENOID	UD SOLENOID	OD SOLENOID	2nd CLUT SOLENOID	4th CLUT SOLENOID	Multi-Select SOLENOID	Variable Force SOLENOID
P/N Under 8	ON					OFF	Modulating
P/N Over 8						ON	Modulating
REVERSE							Modulating
REV-Block						ON	Modulating
OD-1ST	ON					ON	Modulating
OD-2ND	*			ON		ON	Modulating
2ND PRIME	*		ON		ON	ON	Modulating
OD-3RD	*		ON				Modulating
OD-4TH	*	ON	ON		ON		Modulating
(1)-1ST Or Autostick	ON					ON	Modulating
FAILSAFE	OFF	OFF	OFF	OFF	OFF	OFF	OFF
* Modulating (EMCC) if the Converter Clutch has been signaled.							
Copyright © 1999 ATSG							

Figure 3



Technical Service Information

ELECTRICAL OPERATION

The Transmission Control Module (TCM) controls *all* of the transmission functions and is located in the engine compartment, as shown in Figure 5. The Powertrain Control Module (PCM) *does not* control the transmission. The electronic components of the 45RFE transmission consist of various sensors and switches as input information to the TCM, that the TCM uses to determine the appropriate gear ratio and shift schedule points. There is also the associated wiring, fuses, relays, connectors, splices and grounds for the transmission to function as designed. A complete transmission wiring schematic has been provided for you in Figure 9.

The final output from the TCM is to the six shift solenoids and the line pressure control solenoid located in the Solenoid Pack/Transmission Range Sensor assembly and bolted on the valve body as shown in Figure 4. The solenoids in this transmission are unique in that some are normally vented and some are normally applied and is illustrated in Figure 4. The TCM also communicates with other control modules, such as the PCM, currently using the two wire CCD Bus for communication. The TCM receives power from two sources, fused battery power to pin 56 and fused ignition switch input to pin 11, both at the 60-way connector on the TCM. The TCM also has a ground to complete its electrical circuit. (See Figure 8).

INPUTS TO THE TCM

Input and Output Shaft Speed Sensors - are located on the left side of the transmission and are illustrated in Figure 11. The input shaft speed sensor reads input shaft speed off of a tone wheel. The TCM compares this reading with that of the output shaft speed sensor, which is also read off of a tone wheel. This comparison provides the TCM with gear ratio information. The crankshaft position sensor supplies the TCM with engine RPM data that is also critical to scheduling shift points.

Line Pressure Sensor - is located on the right rear of the transmission, as illustrated in Figure 11, and supplies the TCM with line pressure information. The line pressure sensor operates much like a throttle position sensor.

Transmission Fluid Temperature Sensor - is located in the Solenoid Pack/Transmission Range Sensor and is a thermister that the TCM uses to monitor transmission fluid temperature.

Overdrive Cancel Switch - located on the shift lever and cancels overdrive operation.

Solenoid Pack/Transmission Range Sensor - contains several different inputs to the TCM. The TRS contains five switches that tell the TCM, through different combinations of switch states, what position the manual gear selector has been placed. There is also a back-up lamp switch incorporated in the TRS.

In addition to the switches above, there are five pressure switches to monitor pressure in the Low/Rev, Second Clutch, Fourth Clutch, Underdrive Clutch and Overdrive Clutch hydraulic circuits. The primary function of these switches is to help the TCM detect when clutch circuit hydraulic failures occur. The TCM continuously monitors the switches for the correct states (Open or Closed) in each gear as shown in the chart in Figure 5.



Technical Service Information

ADAPTIVE LEARNING

The 45RFE transmission uses an "Adaptive Learning" feature which allows the TCM to modify the clutch apply rate to maintain consistent shift quality. This is done based on the amount of wear on the friction elements. The TCM then adjusts the duty cycle of the shift solenoids to achieve the smoothest possible upshifts and downshifts. The TCM adjusts the "Clutch Volume Index" when a shift change takes place to optimize clutch to clutch timing. Clutch Volume Index is described in Figure 6, along with proper clutch volumes and clutch clearances for the 45RFE transmission.

OUTPUTS FROM THE TCM

Transmission Control Relay - located in the Power Distribution Center (PDC), as shown in Figure 10, and receives a ground signal from terminal 15 at the TCM to close the relay. Refer to the wiring schematic in Figure 9.

Underdrive Solenoid with Pressure Switch - This solenoid is *normally applied* and controls oil to the UD clutch in all 1st, 2nd, 2nd Prime and 3rd gears of the transmission.

Overdrive Solenoid with Pressure Switch - This solenoid is *normally vented* and controls oil to the OD clutch in 3rd and 4th gears in the transmission.

Fourth Clutch Solenoid with Pressure Switch - This solenoid is *normally vented* and controls oil to the 4th clutch in all 4th and 2nd Prime gears in the transmission.

Second Clutch Solenoid with Pressure Switch - This solenoid is *normally vented* and controls oil to the 2nd clutch in all 2nd gears in the transmission.

Low/Reverse Solenoid with Pressure Switch - This solenoid is *normally vented* and is used to apply the L/R clutch in 1st from neutral, or coast down to 1st, and to control oil for converter clutch engagement.

Multi-Select Solenoid - The Multi-Select Solenoid is *normally applied* and controls the OD clutch in 3rd gear Limp-in, 2nd clutch in Manual 2, 2nd Limp-in and the Low/Reverse clutch in reverse.

LIMP-IN MODE OPERATION

The TCM has the ability to monitor all transmission related electrical components and if it detects a problem, takes appropriate action, and most of the time results in the TCM setting a Diagnostic Trouble Code (DTC). Whether this results in MIL illumination, or Limp-in Mode operation, depends on the type of DTC that was set.

If the TCM determines that transmission damage may result from the DTC type that was set, the TCM will shut off the ground signal to the transmission control relay which will shut off all power to the transmission and the vehicle will be in Limp-in Mode Operation.

When in Limp-in Mode Operation, with the shift lever in the "Drive" position the transmission will be in 3rd gear, and if the shift lever is moved to "2" or "L" position the transmission will be in 2nd gear. This will allow the driver to manually shift the transmission to Limp home.

DIAGNOSIS AND SERVICE INFORMATION

You have been provided with the 23-way case connector pin cavity identification and pin function in Figure 7, and 60-way TCM connector pin cavity identification and pin function in Figure 8. A complete transmission wiring schematic is provided in Figure 9, and transmission control relay location in the power distribution center is shown in Figure 10.

Special tools that might be needed are illustrated in Figure 12, along with the identification of the pressure taps that are available on the main valve body. Air pressure test passage identification is provided for you in Figure 13.

Copyright © 1999 ATSG

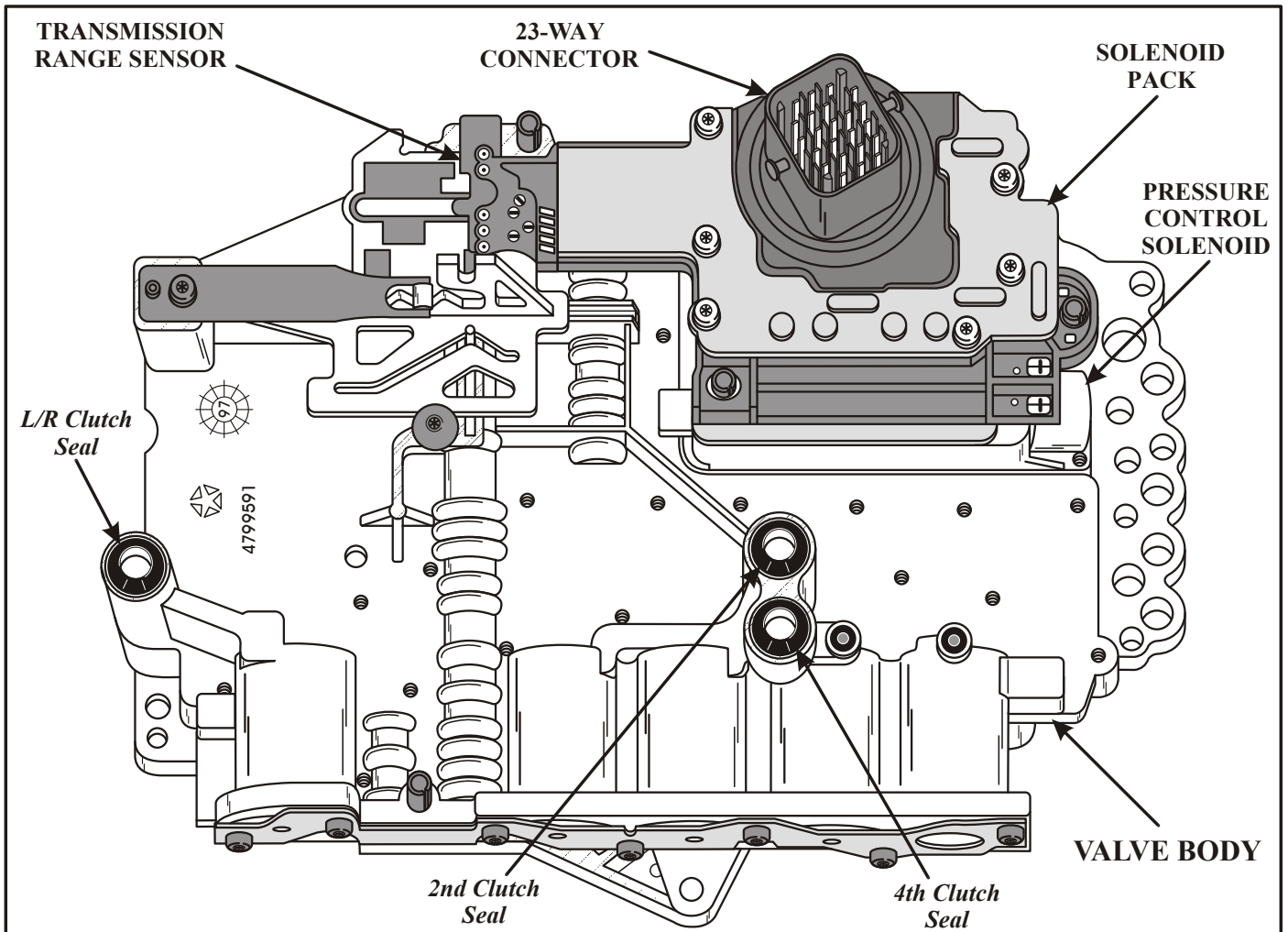

TWO DIFFERENT TYPES OF SHIFT SOLENOIDS

*Underdrive Solenoid
Multi-Select Solenoid*

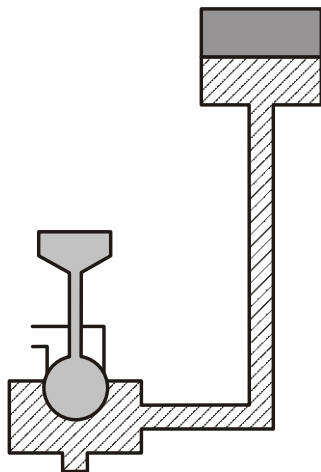

*Overdrive Solenoid
4th Clutch Solenoid
2nd Clutch Solenoid
Low/Reverse Solenoid*

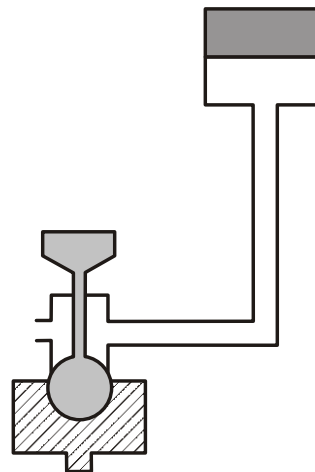

Copyright © 1999 ATSG

Figure 4

PRESSURE SWITCHES

The pressure switches are located inside the solenoid and pressure switch assembly and are only serviced by replacing the complete assembly.

The Transmission Control Module (TCM) is located as shown below and relies on five pressure switches to monitor pressure in the Low/Rev, 2nd Clutch, 4th Clutch, Underdrive, and Overdrive hydraulic circuits. The primary function of these switches is to help the TCM detect when the clutch circuit hydraulic failures occur. The switches close at 23 psi and open at 11 psi, and indicate whether or not pressure exists. The switches are continuously monitored by the TCM for the correct states (Open or Closed) in each gear as shown in the chart below.

SWITCH CHART

	<i>Low/Rev</i>	<i>2nd Clut</i>	<i>4th Clut</i>	<i>Underdrive</i>	<i>Overdrive</i>
<i>Park/Neut</i>	<i>Closed</i>	<i>Open</i>	<i>Open</i>	<i>Open</i>	<i>Open</i>
<i>Reverse</i>	<i>Open</i>	<i>Open</i>	<i>Open</i>	<i>Open</i>	<i>Open</i>
<i>First</i>	<i>Closed*</i>	<i>Open</i>	<i>Open</i>	<i>Closed</i>	<i>Open</i>
<i>Second</i>	<i>Open</i>	<i>Closed</i>	<i>Open</i>	<i>Closed</i>	<i>Open</i>
<i>2nd Prime</i>	<i>Open</i>	<i>Open</i>	<i>Closed</i>	<i>Closed</i>	<i>Open</i>
<i>Third</i>	<i>Open</i>	<i>Open</i>	<i>Open</i>	<i>Closed</i>	<i>Closed</i>
<i>Fourth</i>	<i>Open</i>	<i>Open</i>	<i>Closed</i>	<i>Open</i>	<i>Closed</i>

* *L/R is closed if output speed is below 150 RPM in Drive and Manual 2.
L/R is open in Manual 1.*

**TRANSMISSION
CONTROL MODULE**

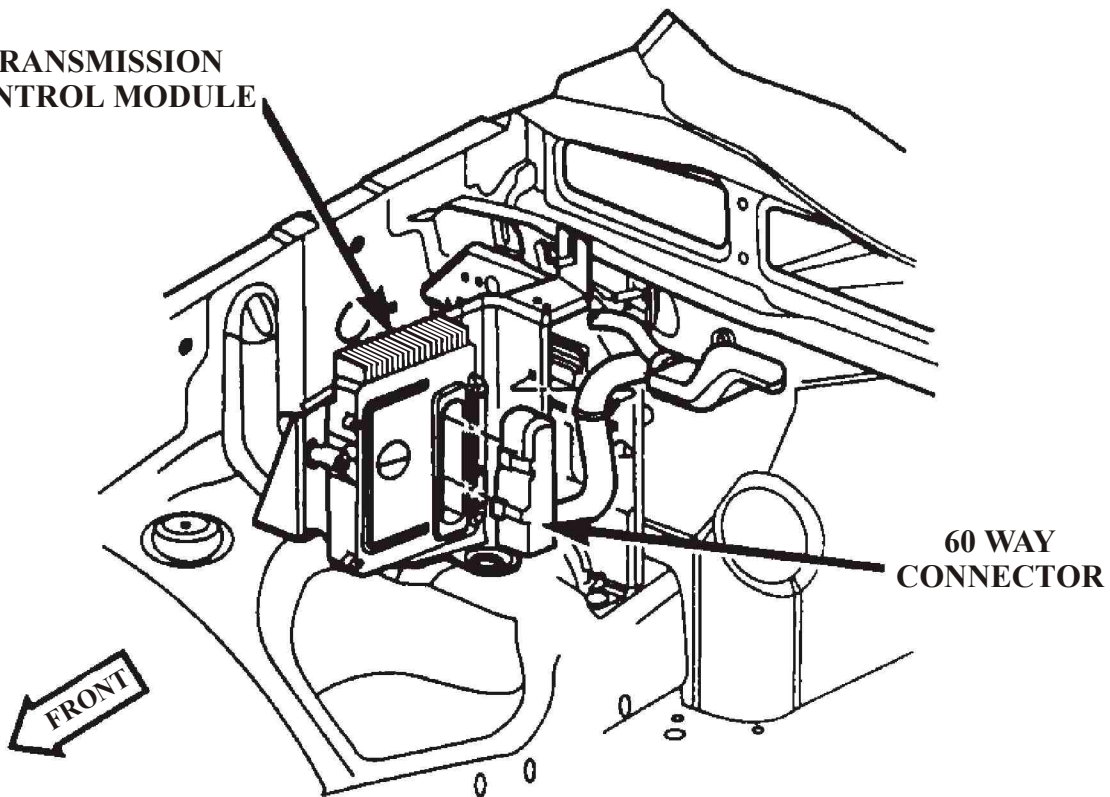

Copyright © 1999 ATSG

Figure 5



Technical Service Information

CLUTCH VOLUME INDEXES

An important function of the TCM is to monitor Clutch Volume Indexes (CVI). CVIs represent the volume of fluid needed to compress a clutch pack properly.

The TCM monitors gear ratio changes by monitoring the Input and Output Speed Sensors. The Input Speed Sensor sends an AC voltage signal to the TCM that represents input shaft rpm. The Output Speed Sensor provides the TCM with output shaft speed information.

By comparing these two inputs, the TCM can determine actual gear ratio. This is important to the CVI calculation because the TCM determines CVIs by monitoring how long it takes for a gear change to occur.

Gear ratios can be determined by using the DRB Scan Tool and reading the Input/Output Speed Sensor values in the "Monitors" display. Gear ratio can be obtained by dividing the Input Speed Sensor value by the Output Speed Sensor value.

For example, if the input shaft is turning at 1000 rpm and the output shaft is turning at 500 rpm, the TCM can determine that the gear ratio is 2:1. In 3rd gear the gear ratio changes to 1:1. The gear ratio changes as clutches are applied and released. By monitoring the length of time it takes for a gear ratio to change following a shift request, the TCM can determine the volume of fluid used to apply or release a friction element.

The volume of transmission fluid needed to apply the friction elements are continuously updated for the adaptive controls. As friction material wears, the volume of fluid needed to apply the friction element increases. Certain mechanical problems within the transmission assembly such as broken return springs, out of position snap rings, excessive clutch pack clearance, or improper assembly can cause inadequate or out-of-range CVI readings. Also defective Input/Output Speed Sensors, wiring and poor connections may cause these same conditions. The following chart identifies the proper CVIs, when they are monitored and updated and the proper clutch pack clearances.

CLUTCH VOLUMES AND CLEARANCES			
<i>CLUTCH</i>	<i>WHEN UPDATED</i>	<i>PROPER VOLUME</i>	<i>CLUTCH CLEARANCE</i>
<i>Low/Reverse</i>	<i>2-1 or 3-1 Downshift</i>	<i>82 to 134</i>	<i>1.14-1.91mm (.045"-.075")</i>
<i>2nd Clutch</i>	<i>3-2 Kickdown shift</i>	<i>25 to 64</i>	<i>0.53-1.27mm (.021"-.050")</i>
<i>Overdrive</i>	<i>2-3 Upshift</i>	<i>30 to 64</i>	<i>1.01-1.65mm (.040"-.065")</i>
<i>4th Clutch</i>	<i>3-4 Upshift</i>	<i>30 to 64</i>	<i>0.81-1.35mm (.032"-.053")</i>
<i>Underdrive</i>	<i>4-3 Kickdown shift</i>	<i>44 to 92</i>	<i>0.76-1.60mm (.030"-.063")</i>
<i>Reverse</i>	<i>Not Monitored</i>	<i>Not Monitored</i>	<i>0.81-1.24mm (.032"-.049")</i>

Figure 6

23-WAY CASE CONNECTOR PIN CAVITY IDENTIFICATION AND FUNCTION

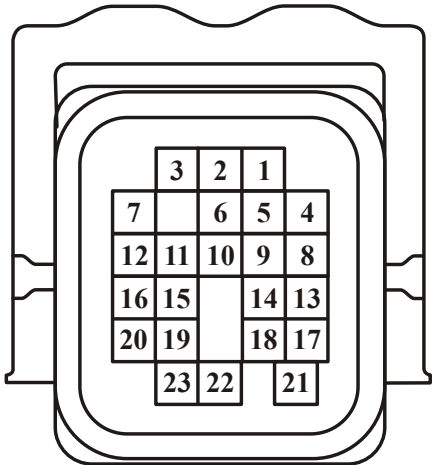

Vehicle Harness Connector

"Front"
←



Transmission Case Connector

PIN CAVITY	WIRE COLOR	FUNCTION
1	White/Tan	Fused Ignition Switch Battery Voltage
2	Lt. Green	LR/TC Clutch Solenoid Control
3	Brown/Yellow	Park/Neutral Position Switch Signal
4	White	Transmission Range Sensor (T41) Signal
5	Violet/White	Transmission Range Sensor (T42) Signal
6	Violet/Black	Back-Up Lamp Feed
7	Brown	Overdrive Clutch Solenoid Control
8	Violet	Transmission Range Sensor (T3) Signal
9	Lt. Green/Black	Transmission Range Sensor (T1) Signal
10	Red	Transmission Control Relay Output
11	Dk. Blue	4th Clutch Pressure Switch Signal
12	Yellow/Dk. Blue	Line Pressure Control Solenoid Control
13	Tan/Black	Transmission Range Sensor (T2) Signal
14	Brown/Lt. Blue	Low/Reverse Clutch Pressure Switch Signal
15	Lt. Blue	2nd Clutch Pressure Switch Signal
16	Orange/Black	Overdrive Clutch Pressure Switch Signal
17	Pink	Underdrive Clutch Solenoid Control
18	Gray	Underdrive Clutch Pressure Switch Signal
19	Dk. Green/White	4th Clutch Solenoid Control
20	White/Dk. Blue	2nd Clutch Solenoid Control
21	Violet/Lt. Green	Multi-Select Solenoid Control
22	Dk. Blue/Black	Speed Sensor Ground
23	Violet	Transmission Oil Temperature Sensor Signal

Copyright © 1999 ATSG

Figure 7

60-WAY CONNECTOR PIN CAVITY IDENTIFICATION AND FUNCTION

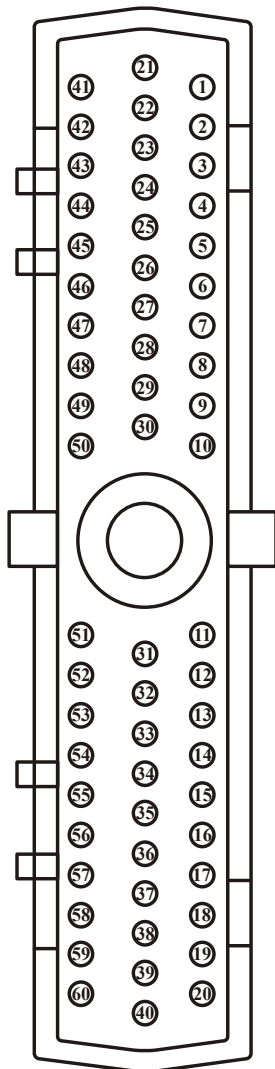

PIN CAVITY	WIRE COLOR	FUNCTION
1	<i>Lt. Green/Black</i>	<i>Transmission Range Sensor T1 Signal</i>
2	<i>Tan/Black</i>	<i>Back-up Lamp Relay Control</i>
3	<i>Violet</i>	<i>Transmission Range Sensor T3 Signal</i>
6	<i>Gray/Black</i>	<i>Crankshaft Position Sensor Signal</i>
7	<i>Pink</i>	<i>SCI Transmit</i>
8	<i>Red</i>	<i>Fused Ignition Switch Output (Start)</i>
9	<i>Orange/Black</i>	<i>Overdrive Clutch Pressure Switch Signal</i>
10	<i>Yellow/Dk. Green</i>	<i>Torque Management Request</i>
11	<i>Orange/Dk. Blue</i>	<i>Fused Ignition Switch Output (Start-Run)</i>
12	<i>Brown</i>	<i>Overdrive Clutch Solenoid Control</i>
13	<i>Dk. Blue/Black</i>	<i>Speed Sensor Ground</i>
14	<i>Lt. Green/White</i>	<i>Output Speed Sensor Signal</i>
15	<i>Pink/Yellow</i>	<i>Transmission Control Relay Control</i>
16	<i>Red</i>	<i>Transmission Control Relay Output</i>
17	<i>Red</i>	<i>Transmission Control Relay Output</i>
18	<i>Yellow/Dk. Blue</i>	<i>Line Pressure Control Solenoid Control</i>
19	<i>White/Dk. Blue</i>	<i>2nd Clutch Solenoid Control</i>
20	<i>Lt. Green</i>	<i>L/R-TCC Clutch Solenoid Control</i>
28	<i>White/Orange</i>	<i>Vehicle Speed Sensor Signal</i>
29	<i>Gray</i>	<i>Underdrive Clutch Pressure Switch Signal</i>
30	<i>Violet/Tan</i>	<i>Line Pressure Sensor Signal</i>
36	<i>Red</i>	<i>Transmission Control Relay Output</i>
37	<i>Black/Yellow</i>	<i>Ground</i>
38	<i>Gray/Lt. Blue</i>	<i>5 Volt Supply</i>
39	<i>Black/Yellow</i>	<i>Ground</i>
40	<i>Violet/Lt. Green</i>	<i>Multi-Select Solenoid Control</i>
41	<i>White</i>	<i>Transmission Range Sensor (T41) Signal</i>
42	<i>Violet/White</i>	<i>Transmission Range Sensor (T42) Signal</i>
43	<i>Yellow/Violet</i>	<i>PCI Bus</i>
46	<i>Lt. Green</i>	<i>SCI Recieve</i>
47	<i>Lt. Blue</i>	<i>2nd Clutch Pressure Switch Signal</i>
48	<i>Dk. Blue</i>	<i>4th Clutch Pressure Switch Signal</i>
49	<i>Violet/White</i>	<i>Overdrive Off Switch Signal</i>
50	<i>Brown/Lt. Blue</i>	<i>Low/Reverse Clutch Pressure Switch Signal</i>
51	<i>Black/Lt. Blue</i>	<i>Sensor Ground</i>
52	<i>Red/Black</i>	<i>Input Speed Sensor Signal</i>
53	<i>Black/Red</i>	<i>Ground</i>
54	<i>Violet</i>	<i>Transmission Oil Temperature Sensor Signal</i>
55	<i>Pink</i>	<i>Underdrive Clutch Solenoid Control</i>
56	<i>Red/White</i>	<i>Fused Battery Voltage</i>
57	<i>Black/Yellow</i>	<i>Ground</i>
59	<i>Dk. Green/White</i>	<i>4th Clutch Solenoid Control</i>
60	<i>Brown</i>	<i>Overdrive Clutch Solenoid Control</i>

Copyright © 1999 ATSG

Figure 8

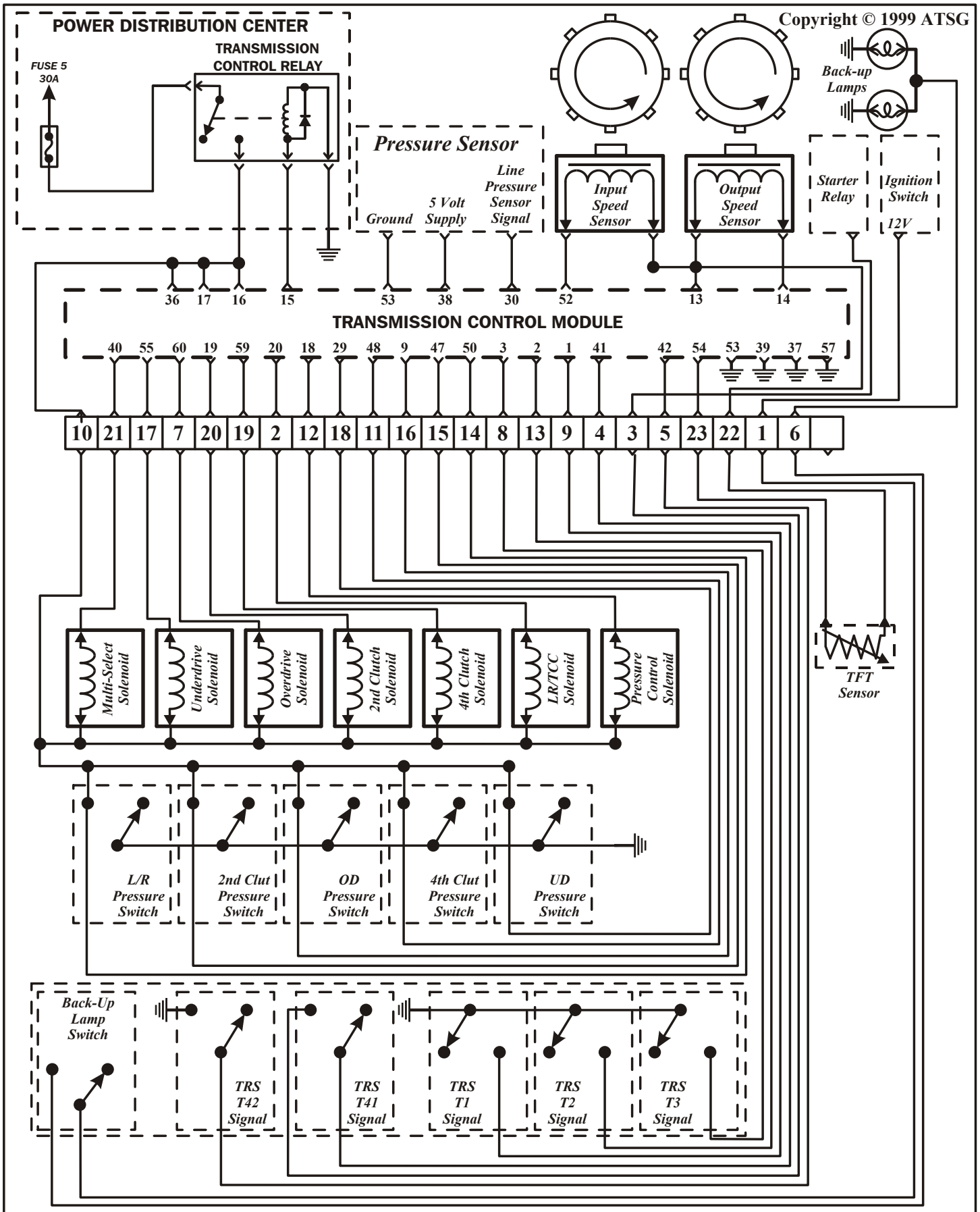
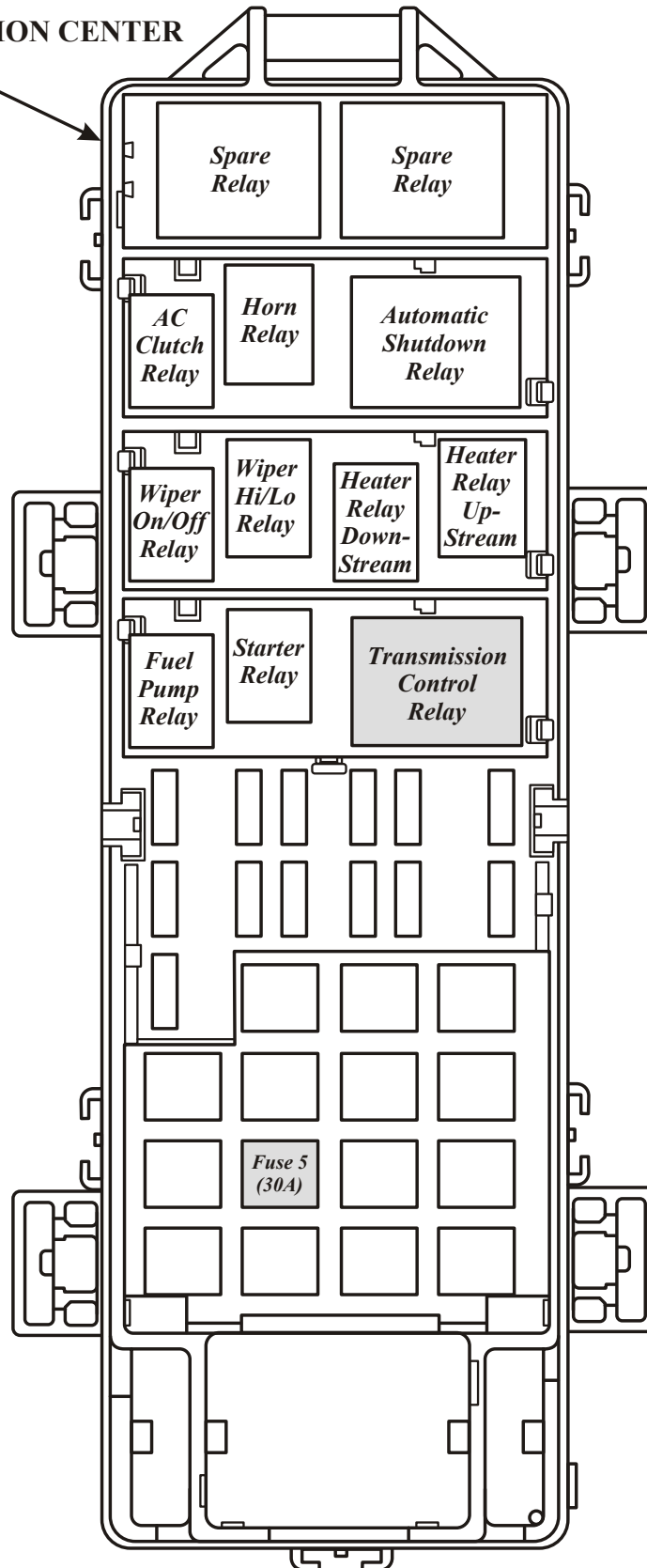

Figure 9

TRANSMISSION CONTROL RELAY AND FUSE LOCATIONS

POWER DISTRIBUTION CENTER



Copyright © 1999 ATSG

Figure 10

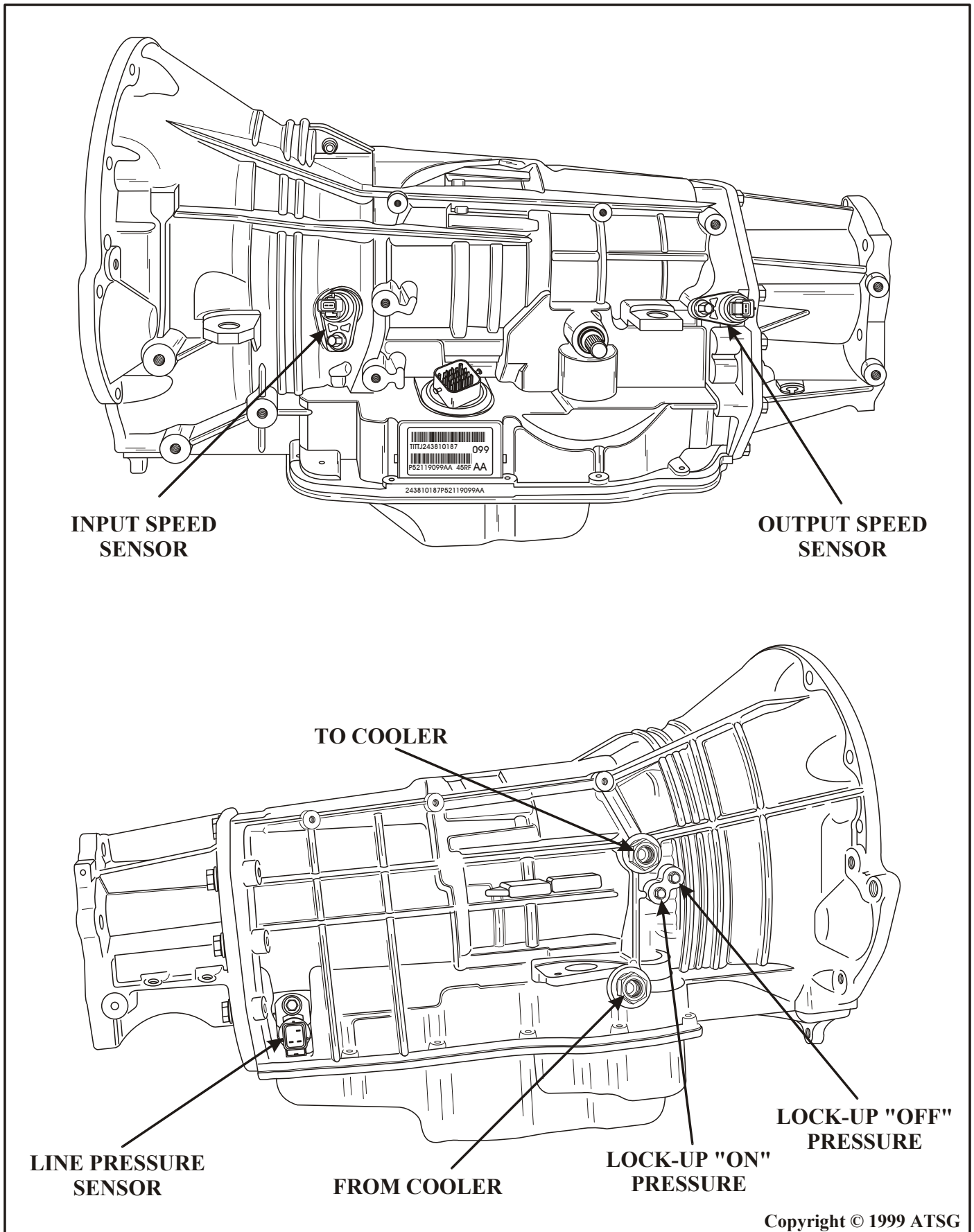

Copyright © 1999 ATSG

Figure 11

MANDATORY TOOLS NEEDED FOR CHECKING PRESSURES ON 45RFE

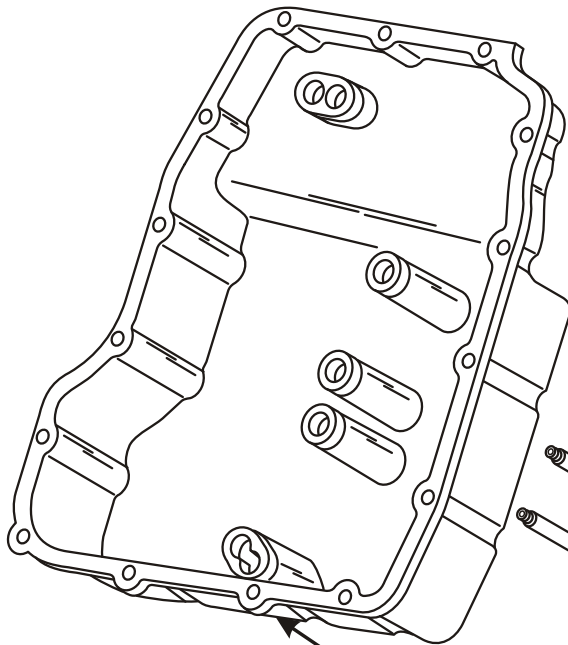

Pressure Tap Adapter Tool No. 8258, to check oil pressures through the valve body taps.

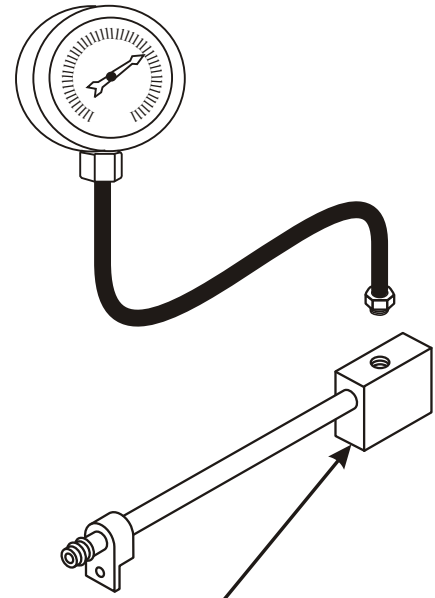

Line Pressure Adapter Tool No. 8259, to install into the line pressure sensor circuit, and then reinstall the sensor and pressure gage.

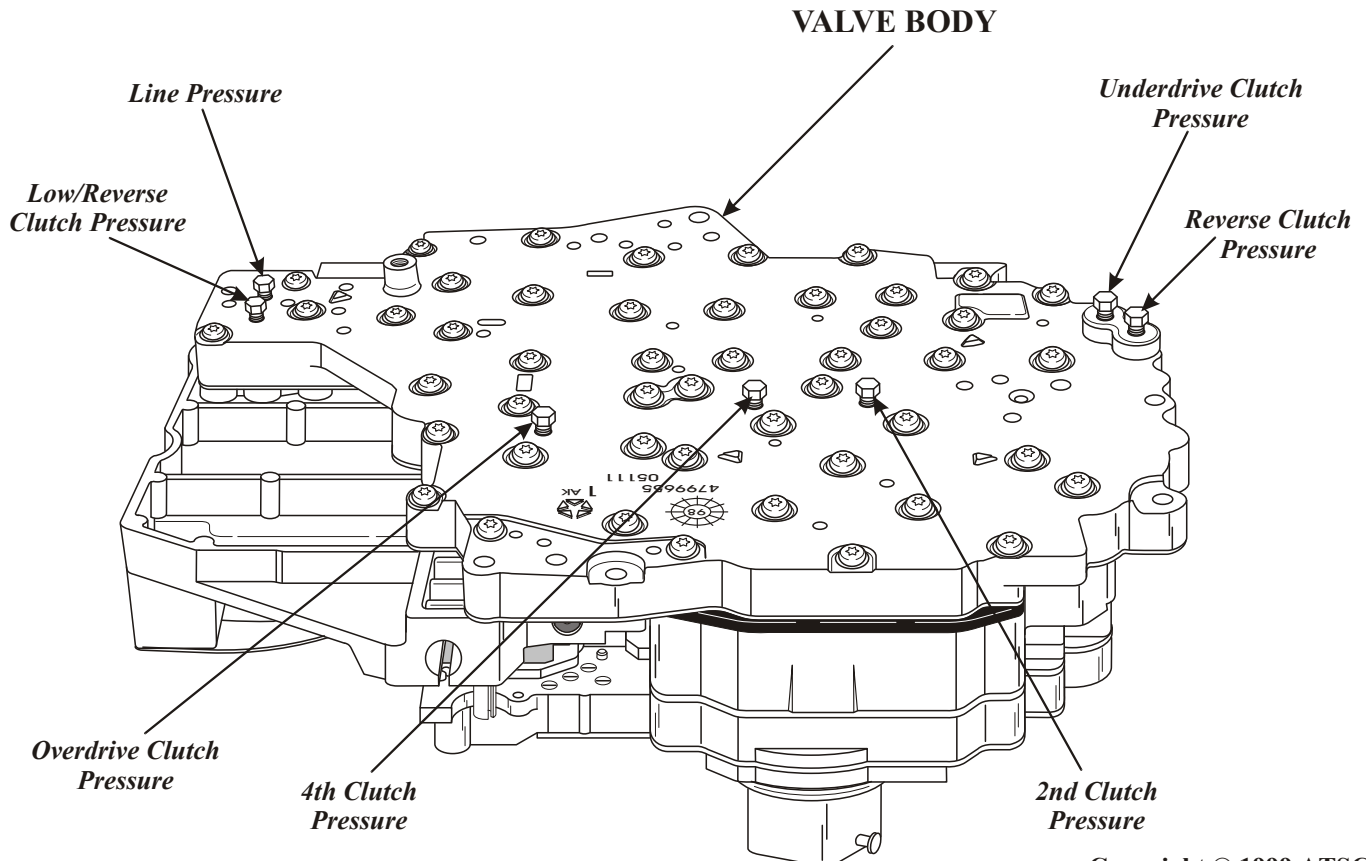

Copyright © 1999 ATSG

Figure 12

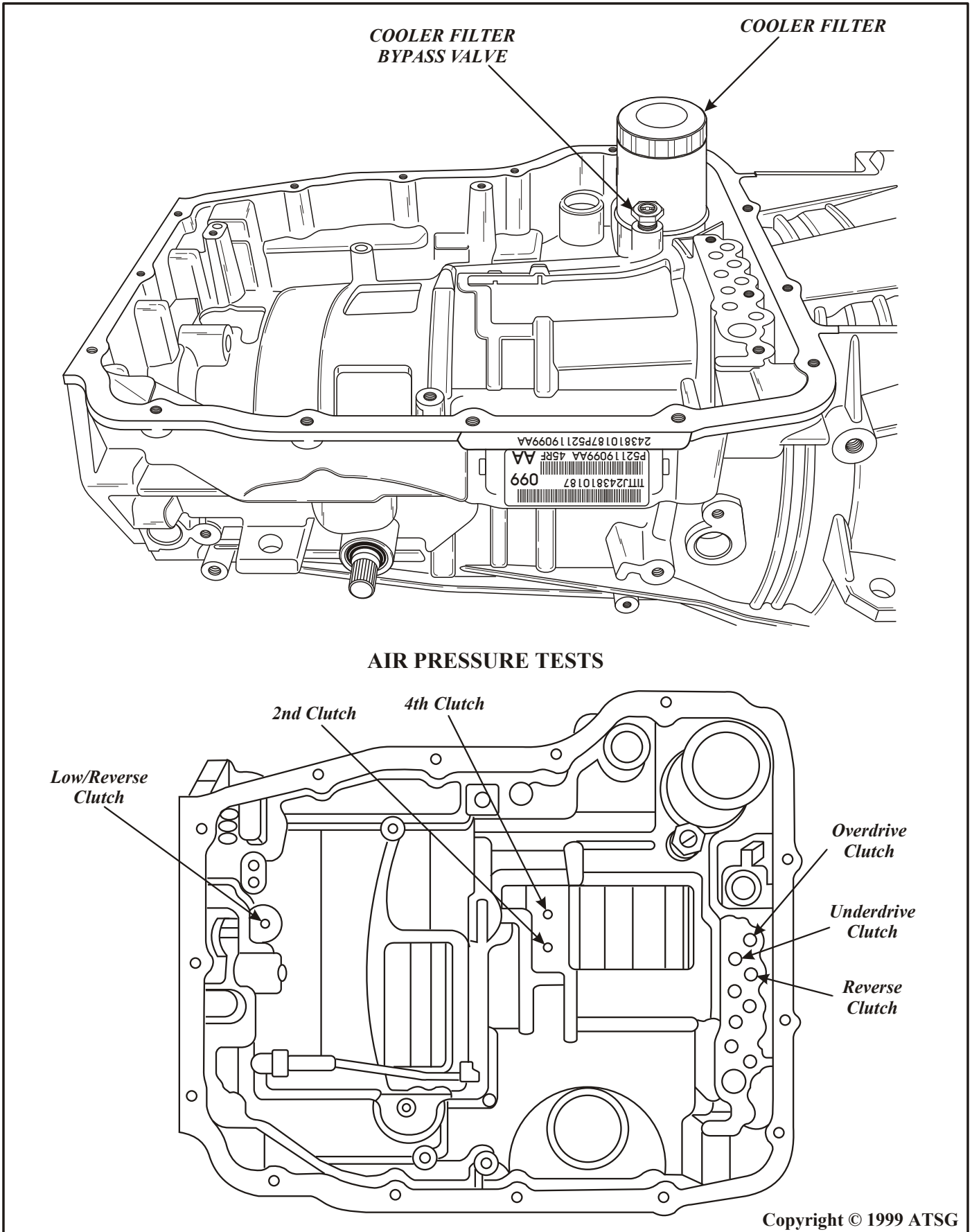
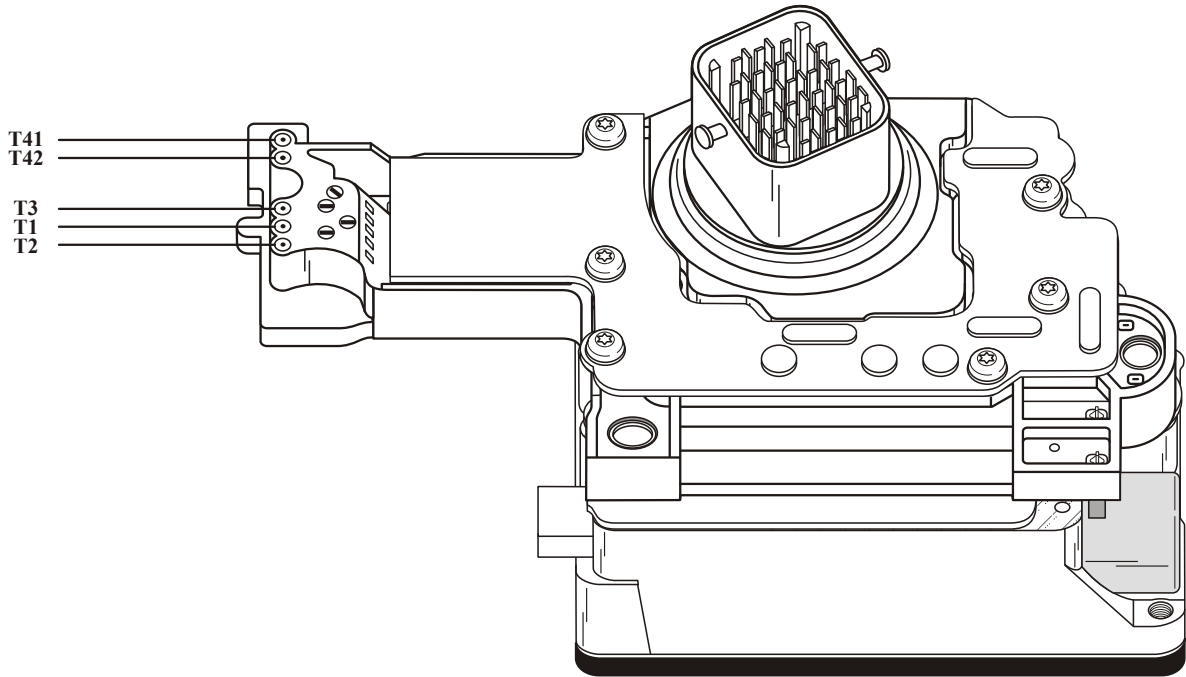

Figure 13

TRS/SOLENOID BODY TESTS



TRANSMISSION RANGE SENSOR CHART

CIRCUIT	METER	P	R	N	OD	2	1
T41	T41 & GRD OR CONNECTOR PIN 4 & GRD	C	O	C	O	O	O
T42	T42 & GRD OR CONNECTOR PIN 5 & GRD	C	C	C	O	O	O
T3	T3 & GRD OR CONNECTOR PIN 8 & GRD	O	O	C	C	O	C
T1	T1 & GRD OR CONNECTOR PIN 9 & GRD	O	O	O	C	C	O
T2	T2 & GRD OR CONNECTOR PIN 13 & GRD	C	O	O	O	C	C

C = Closed O = Open

SOLENOID RESISTANCE CHART

SOLENOID	CONNECTOR PINS	RESISTANCE
LR/TCC	10 AND 2	1.9 W @ 72°F
OVERDRIVE	10 AND 7	1.9 W @ 72°F
UNDERDRIVE	10 AND 17	1.9 W @ 72°F
2ND CLUTCH	10 AND 20	1.9 W @ 72°F
4TH CLUTCH	10 AND 19	1.9 W @ 72°F
MULTI-SELECT	10 AND 21	1.9 W @ 72°F
LINE PRESSURE	10 AND 12	4.3 W @ 72°F
TOT SENSOR	22 AND 23	9.37k W @ 72°F

Copyright © 1999 ATSG

Figure 14

Meter shown checking T41 Circuit and should correspond with chart in Figure 14. Solenoid tests must be made thru case connector pins.

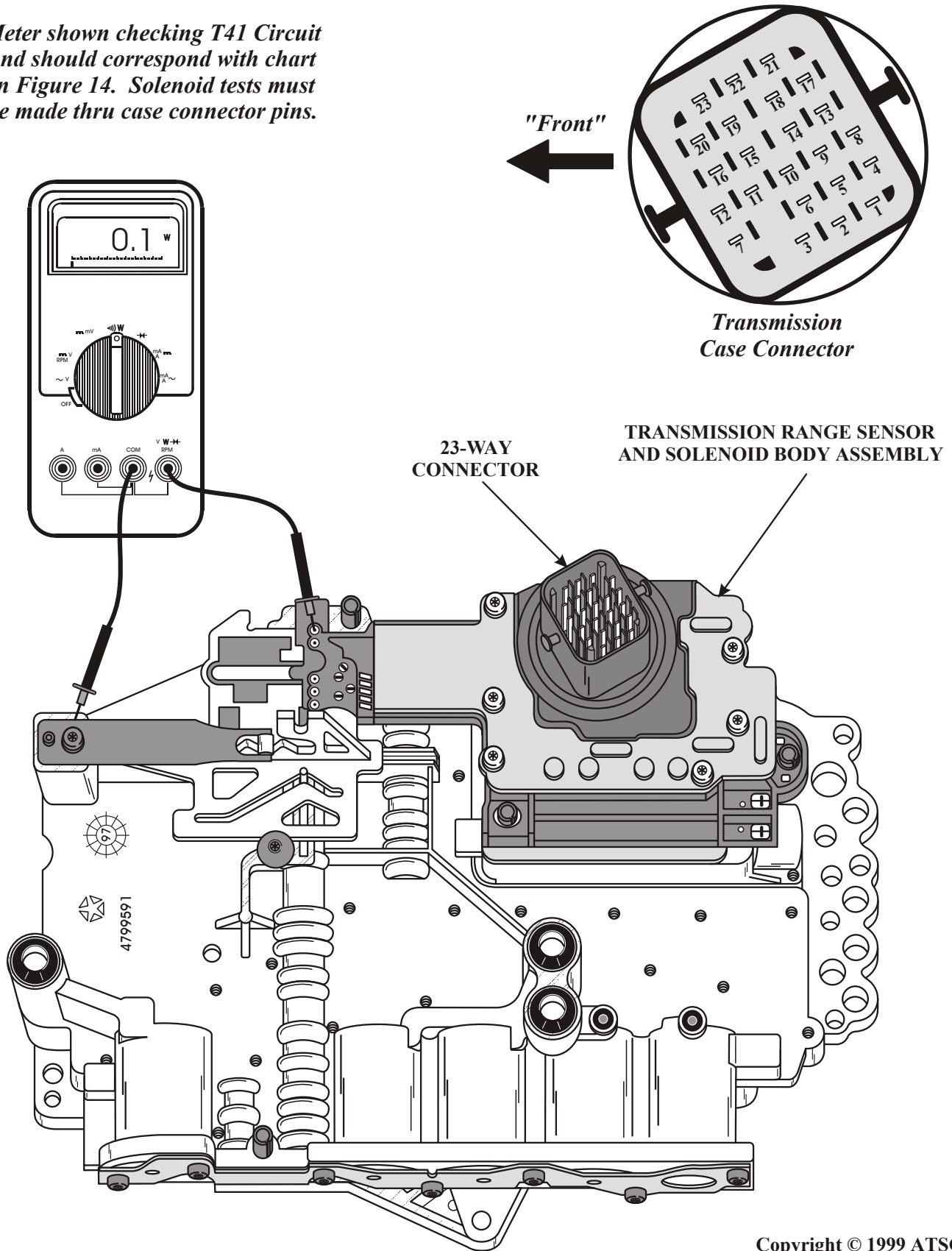

Copyright © 1999 ATSG

Figure 15



Technical Service Information

45RFE OBDII DIAGNOSTIC TROUBLE CODE LIST

OBDII Codes	Description	Limp-in	MIL Illumination
P0120	Throttle Position Signal Out Of Range (29)	NO	NO
P0600	Bus Communication (19)	NO	NO
P0604	Internal TCM (17)	YES	YES
P0605	Internal TCM (16)	YES	YES
P0700	Internal TCM (11, 13)	YES	YES
P0705	Check Shifter Signal (28)	NO	NO
P0715	Input Speed Sensor Error (56)	YES	YES**
P0720	Output Speed Sensor Error (57)	YES	YES**
P0725	Engine Speed Sensor Circuit Error (18)	YES	YES
P0731	Gear Ratio Error In 1st Gear (51)	YES	YES**
P0732	Gear Ratio Error In 2nd Gear (52)	YES	YES**
P0733	Gear Ratio Error In 3rd Gear (53)	YES	YES**
P0734	Gear Ratio Error In 4th Gear (54)	YES	YES**
P0736	Gear Ratio Error In Reverse (50)	YES	YES**
P0740	Torque Converter Clutch Control Circuit (38)	NO	YES**
P0750	Low/Reverse Solenoid Circuit Error (C1)	YES	YES
P0755	2nd Clutch Solenoid Circuit Error (C2)	YES	YES
P0760	Overdrive Solenoid Circuit Error (C3)	YES	YES
P0765	Underdrive Solenoid Circuit Error (C5)	YES	YES
P0770	4th Clutch Solenoid Circuit Error (C4)	YES	YES
P1715	Restricted Port In T3 Range (65)	NO	NO
P1720	Line Pressure Out Of Range (C8)	NO	NO
P1721	Line Pressure Sensor Voltage Out Of Range (CA)	NO	NO
P1722	Line Pressure Low (C9)	NO	NO
P1724	Line Pressure High (CB)	NO	NO
P1726	Underdrive Hydraulic Pressure Test Failure (BO)	YES	YES
P1727	4th Clutch Hydraulic Pressure Test Failure (A8)	YES	YES
P1728	2nd Clutch Hydraulic Pressure Test Failure (A2)	YES	YES
P1732	Underdrive Pressure Switch Sense Circuit (90)	YES	YES
P1733	4th Clutch Pressure Switch Sense Circuit (88)	YES*	YES
P1734	2nd Clutch Pressure Switch Sense Circuit (82)	YES*	YES
P1735	Inadequate Element Volume 4th Clutch (64)	NO	NO
P1736	Speed Ratio Error 2nd Prime (55)	YES	YES**
P1737	Multi-Select Solenoid Circuit Error (C6)	YES	YES

Copyright © 1999 ATSG

Figure 16



Technical Service Information

45RFE OBDII DIAGNOSTIC TROUBLE CODE LIST

OBDII Codes	Description	Limp-in	MIL Illumination
P1738	High Temperature Operation Activated (75)	NO	NO
P1739	Power-Up At Speed (76)	NO	NO
P1765	Switched Battery (80)	YES	YES
P1767	Transmission Control Relay Always ON (14)	YES	YES
P1768	Transmission Control Relay Always OFF (15)	YES	YES
P1770	Inadequate Element Volume Low/Reverse (60)	NO	NO
P1771	Inadequate Element Volume 2nd Clutch (61)	NO	NO
P1772	Inadequate Element Volume Overdrive (62)	NO	NO
P1773	Inadequate Element Volume Underdrive (63)	NO	NO
P1775	Solenoid Switch Valve Stuck In TCC Position (37)	NO	NO
P1776	Solenoid Switch Valve Stuck In L/R Position (47)	YES	YES**
P1781	Overdrive Pressure Switch Sense Circuit (84)	YES*	YES
P1784	Low/Reverse Pressure Switch Sense Circuit (81)	YES*	YES
P1787	Overdrive Hydraulic Pressure Test Failure (A4)	YES	YES
P1790	Fault Immediately After Shift (36)	NO	NO
P1791	Loss Of Prime (35)	NO	NO
P1792	Battery Was Disconnected (12)	NO	NO
P1793	Torque Management Request (TRD) Sense Circuit (48)	NO	NO
P1794	Speed Sensor Ground Error (58)	YES	YES**
P1795	Internal TCM (45)	NO	NO
P1799	Calculated Oil Temperature In Use (74)	NO	NO

Interchange List From DTC to OBDII

11 = P0700	50 = P0736	80 = P1765	A2 = P1728
12 = P1792	51 = P0731	81 = P1784	A4 = P1787
13 = P0700	52 = P0732	82 = P1734	A8 = P1727
14 = P1767	53 = P0733	84 = P1781	B0 = P1726
15 = P1768	54 = P0734	88 = P1733	C1 = P0750
16 = P0605	55 = P1736	90 = P1732	C2 = P0755
17 = P0604	56 = P0715		C3 = P0760
18 = P0725	57 = P0720		C4 = P0770
19 = P0600	58 = P1794		C5 = P0765
28 = P0705	60 = P1770		C8 = P1720
29 = P0120	61 = P1771		CA = P1721
35 = P1791	62 = P1772		CB = P1724
36 = P1790	63 = P1773		
37 = P1775	64 = P1735		
38 = P0740	65 = P1715		
45 = P1795	74 = P1799		
47 = P1776	75 = P1738		
48 = P1793	76 = P1739		

Copyright © 1999 ATSG

Figure 17

45RFE TRANSFER PLATE

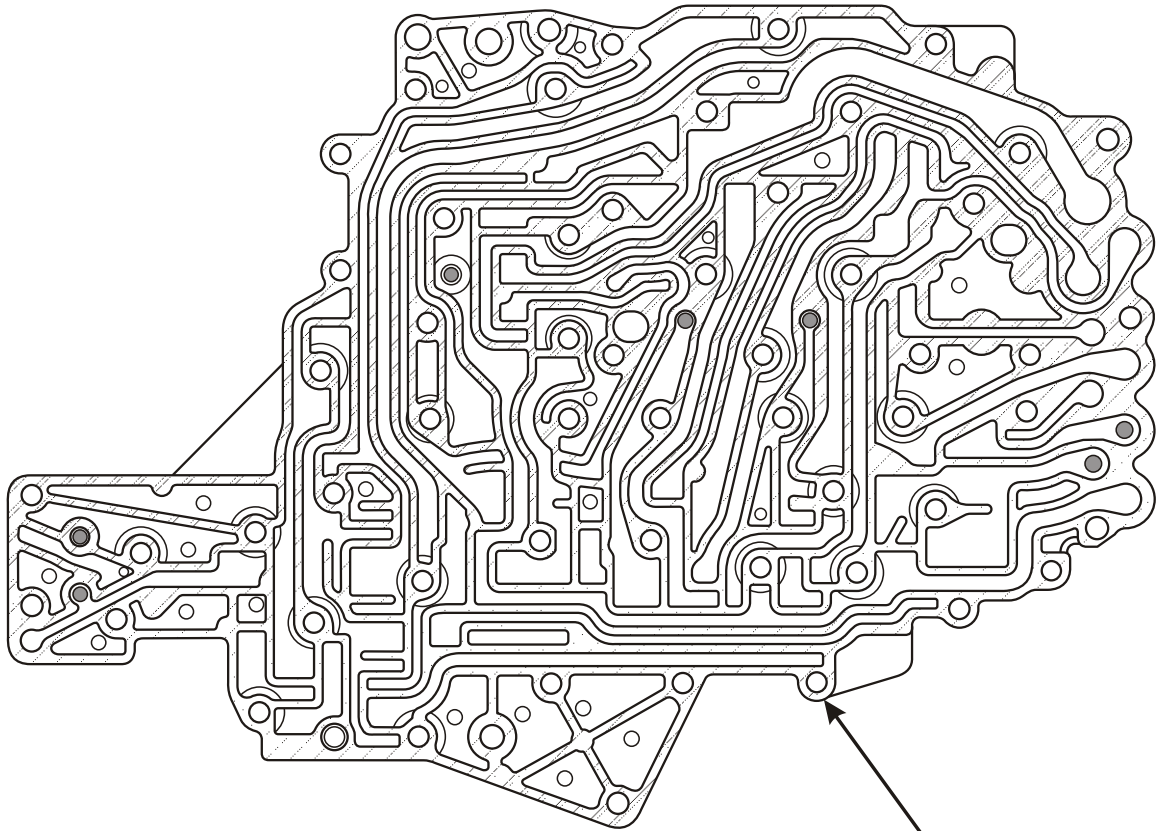

TRANSFER PLATE

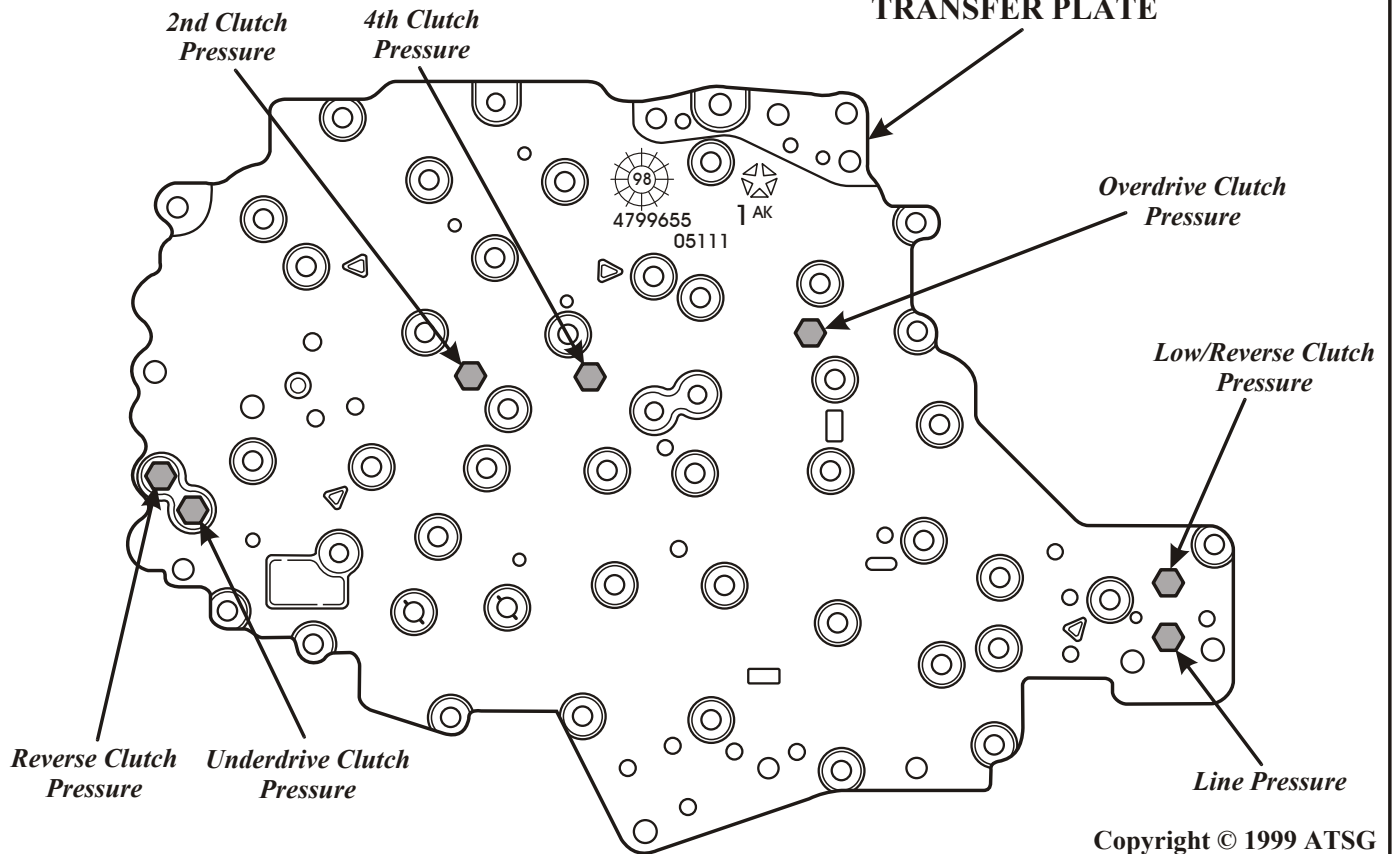

Copyright © 1999 ATSG

Figure 18

45RFE VALVE BODY SPACER PLATE

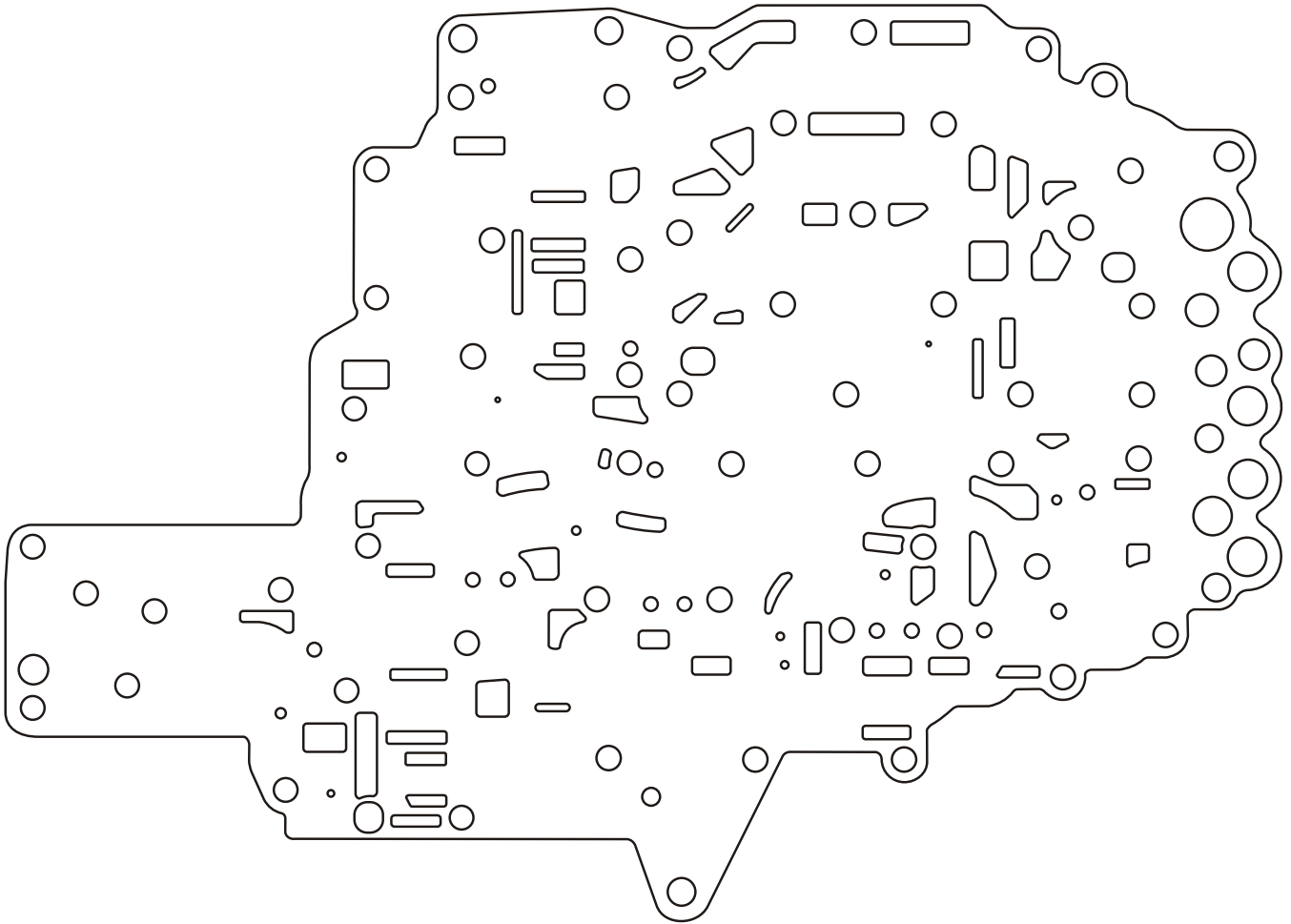

Copyright © 1999 ATSG

Figure 19

45RFE ACCUMULATOR AND CHECKBALL LOCATIONS

*SEVEN CHECKBALL LOCATIONS
ARE SHOWN BELOW*

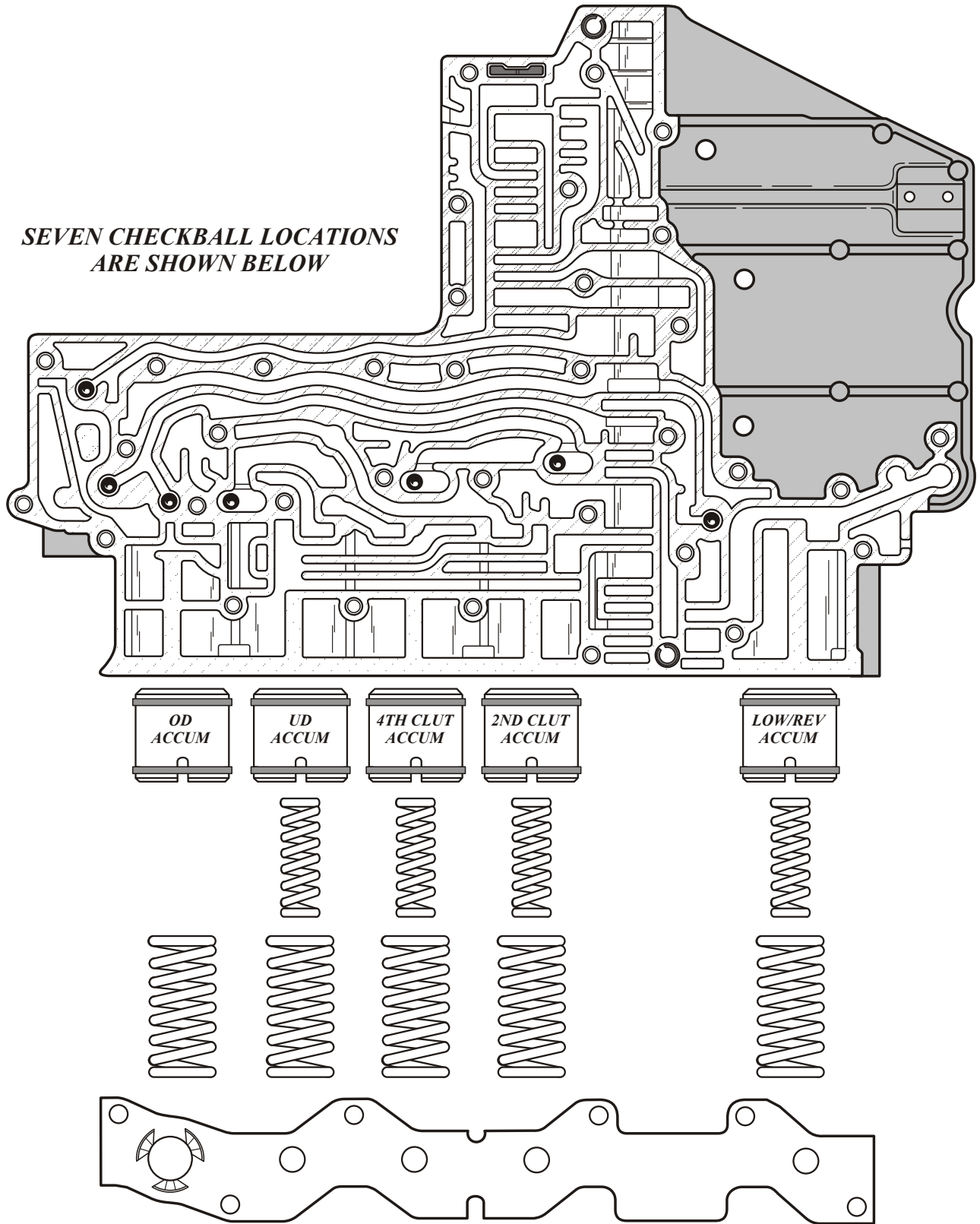

Copyright © 1999 ATSG

Figure 19

45RFE OIL PUMP BODY AND GEARS

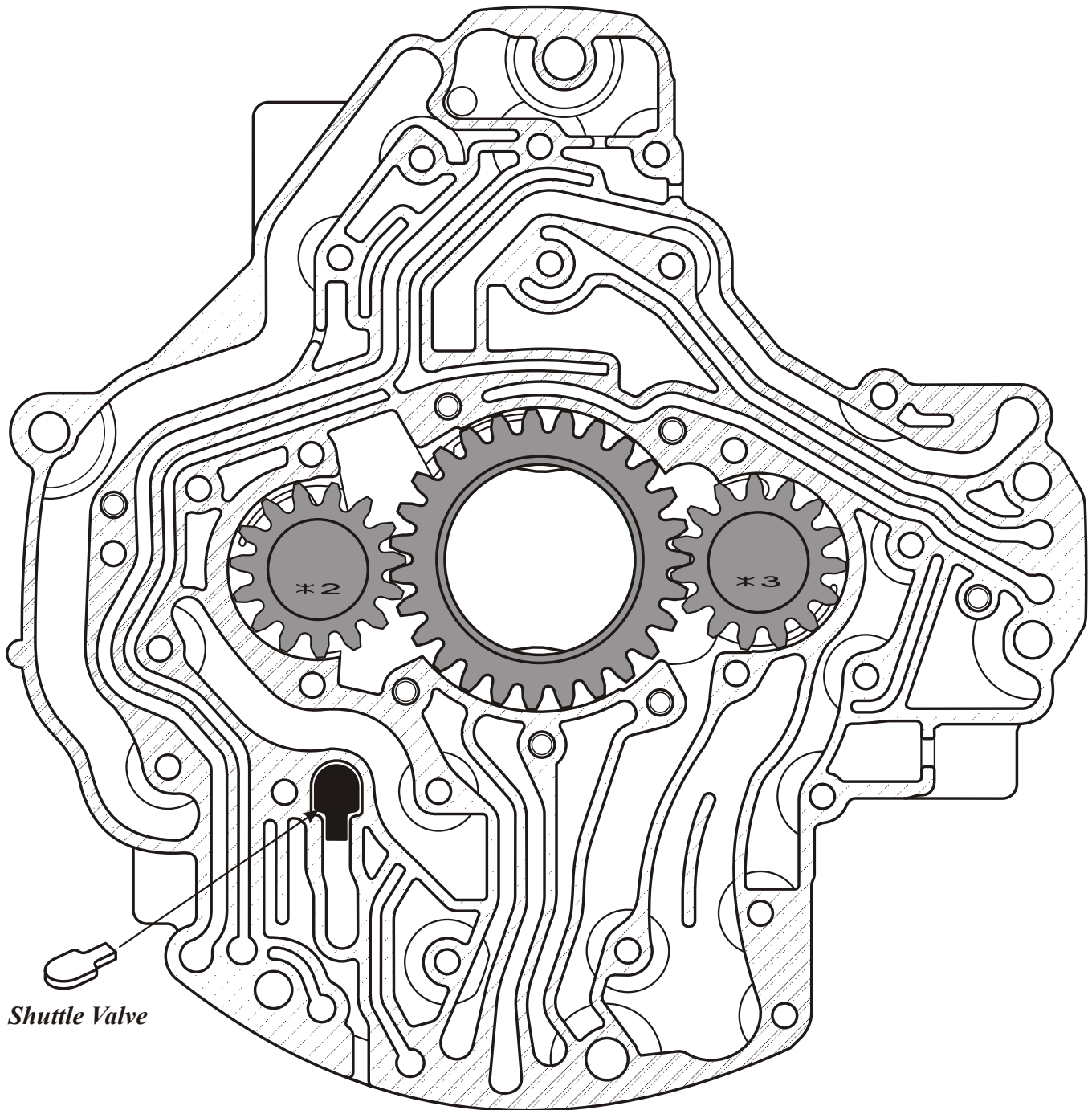

Shuttle Valve

A dual stage oil pump is also new for the 45RFE. The pump has three gears, one drive gear and two driven gears as shown above. Both stages of the pump supply fluid during idle and at low engine speeds. Under these conditions there is not enough pressure from the primary stage to close the shuttle valve. As engine speed increases, so does the output from the primary stage. Once the pressure from the primary stage builds up, the shuttle valve is forced closed and in this condition the secondary stage has no effect and the primary side supplies all of the pressure needed for proper transmission operation.

Copyright © 1999 ATSG

Figure 20

45RFE PUMP SPACER PLATE

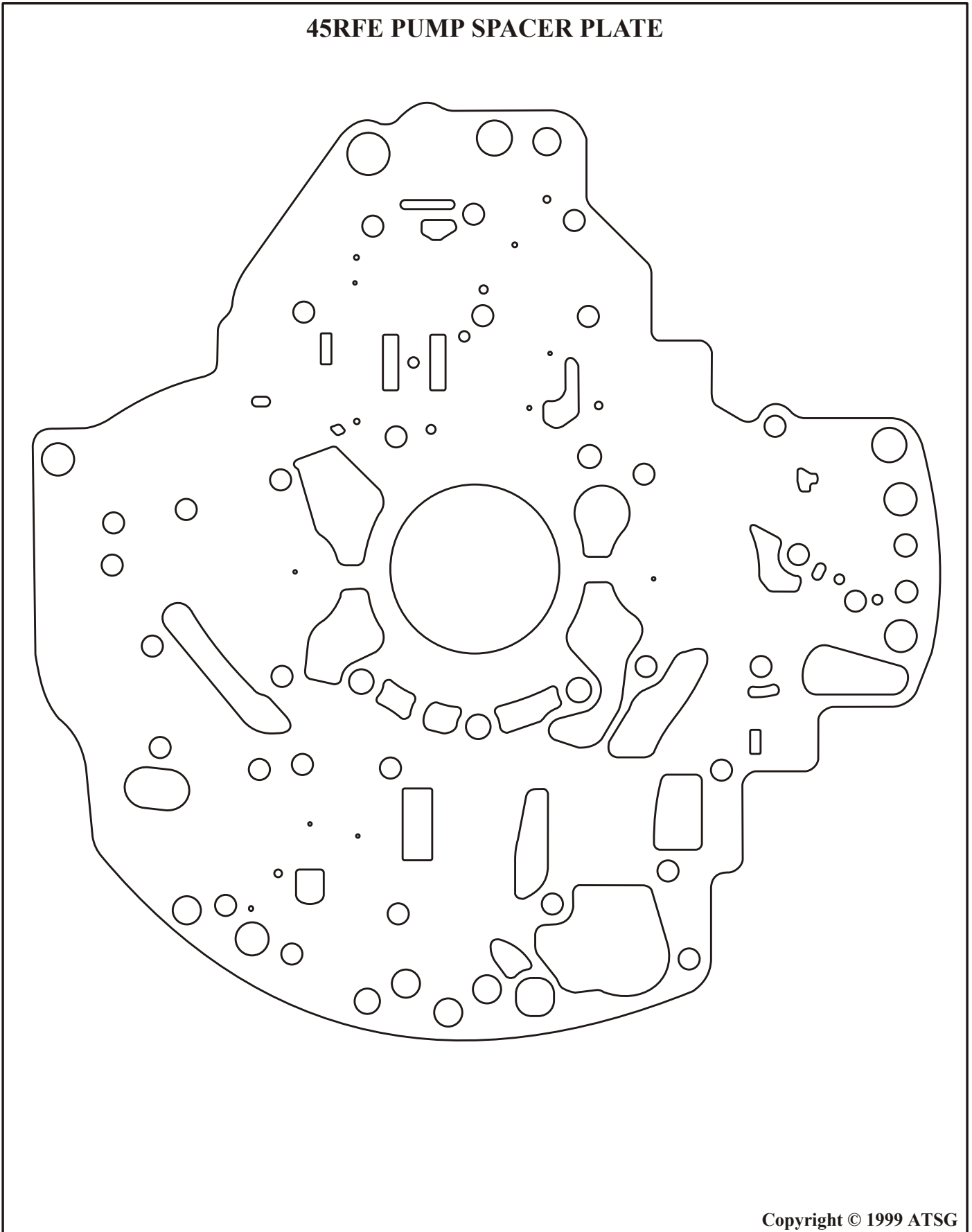

Copyright © 1999 ATSG

Figure 21

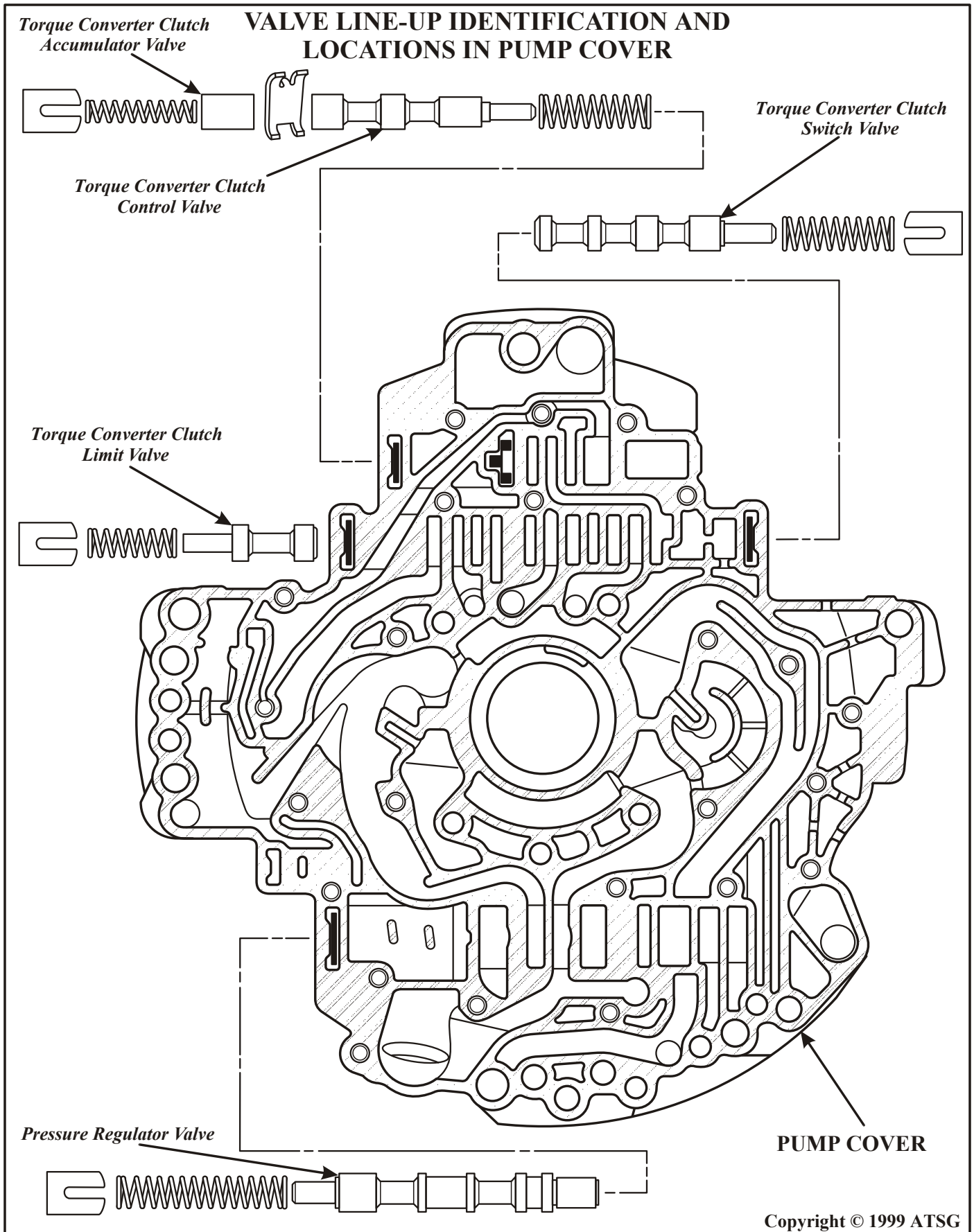
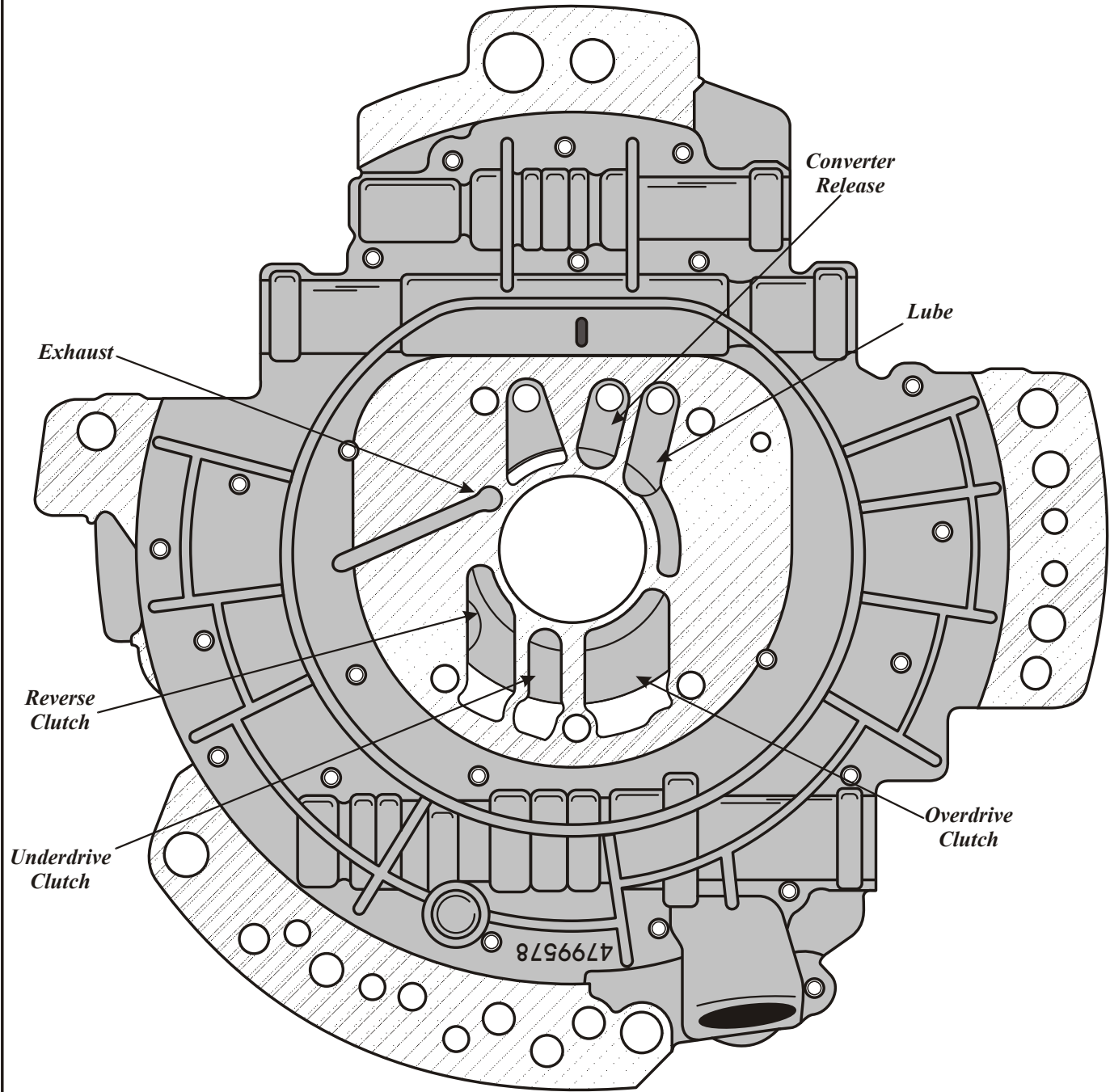

Figure 22

45RFE OIL PUMP COVER PASSAGE AND FEED HOLE IDENTIFICATION



Copyright © 1999 ATSG

Figure 23

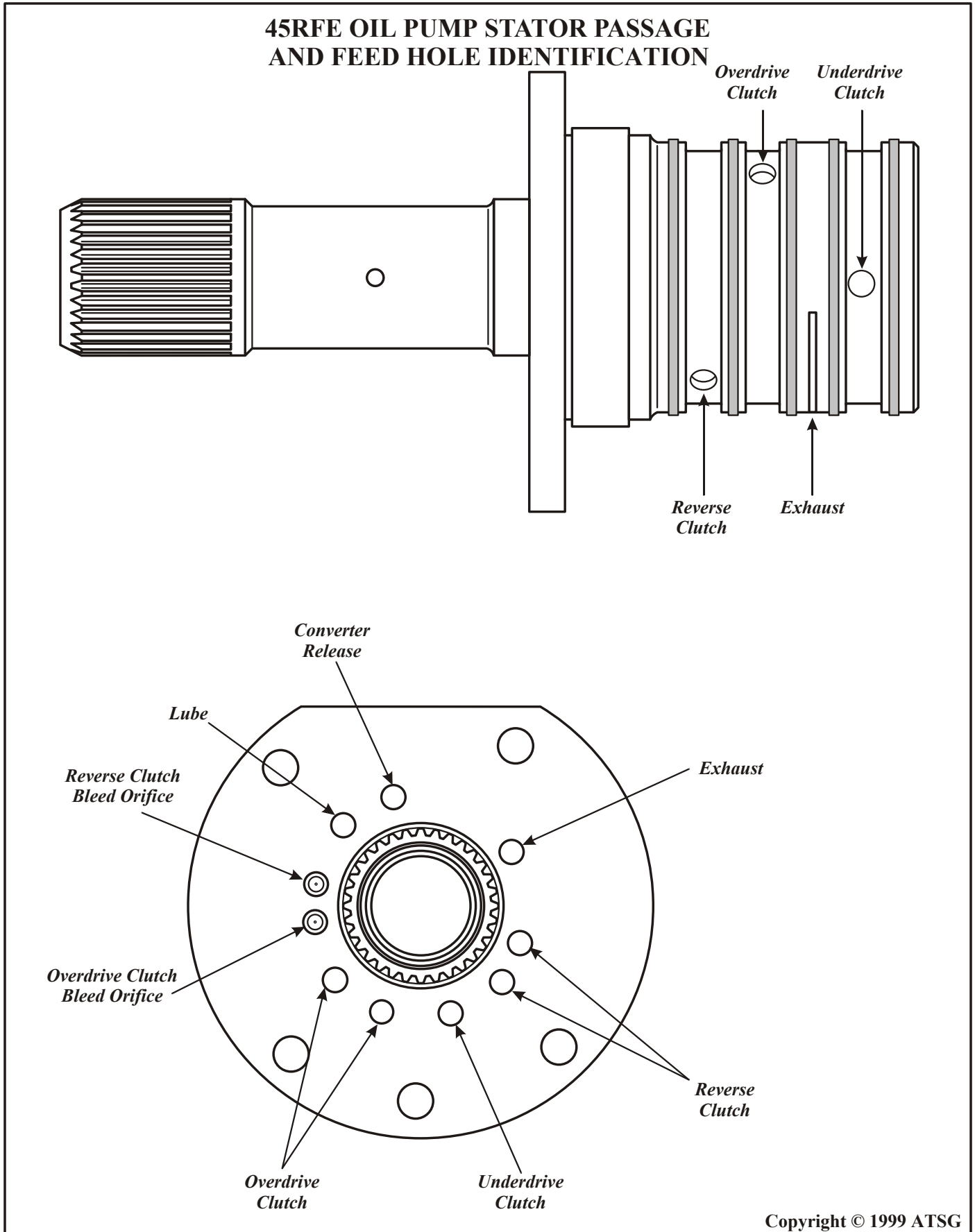

Copyright © 1999 ATSG

Figure 24

OIL PRESSURE TESTS

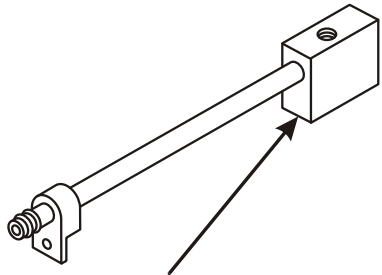

Line Pressure Adapter Tool No. 8259, to install into the line pressure sensor circuit, and then reinstall the sensor and pressure gage.

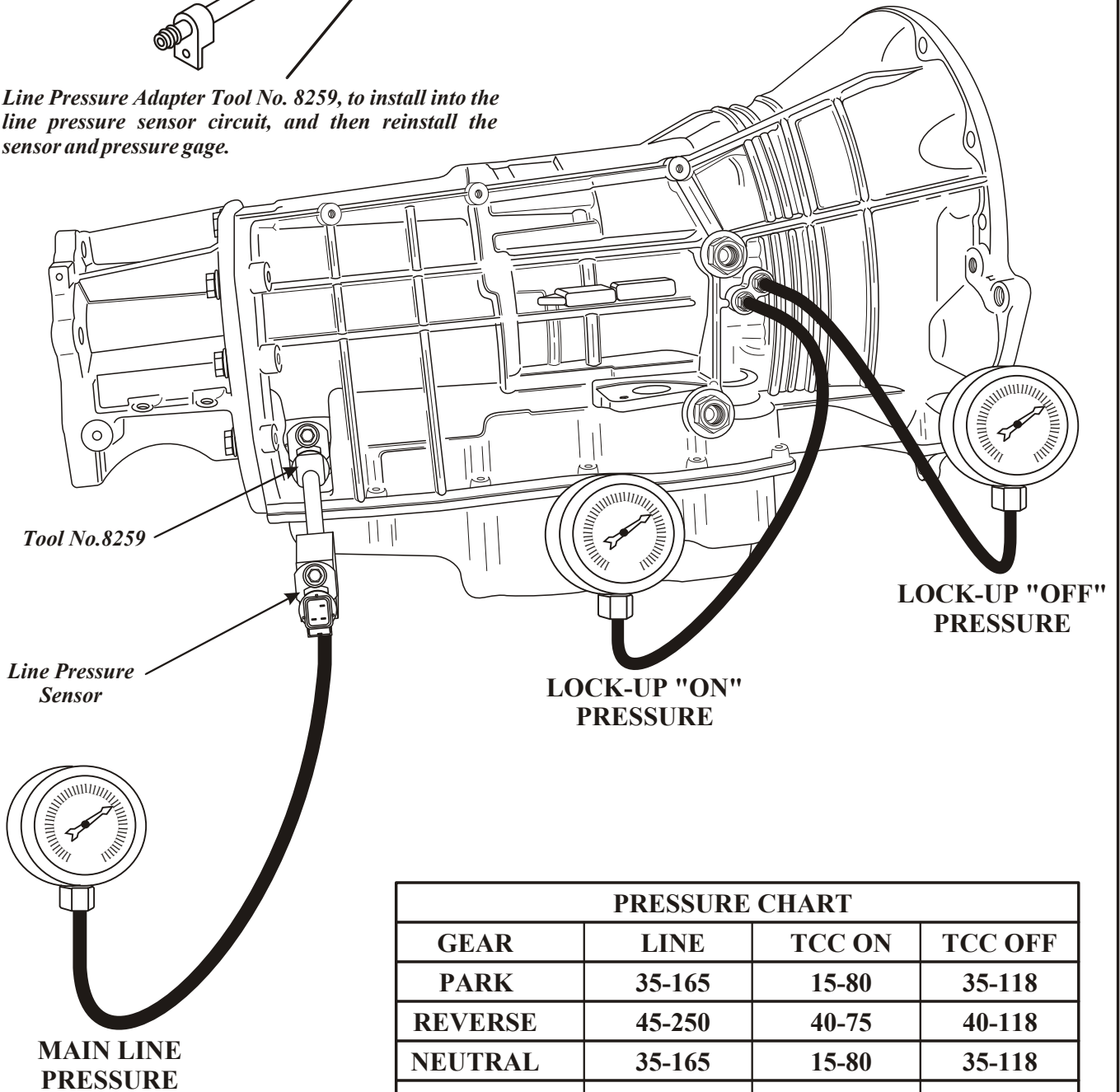

PRESSURE CHART			
GEAR	LINE	TCC ON	TCC OFF
PARK	35-165	15-80	35-118
REVERSE	45-250	40-75	40-118
NEUTRAL	35-165	15-80	35-118
OD-1ST	35-165	15-80	35-118
TCC OFF	35-165	15-80	35-118
TCC ON	35-165	35-80	0

Copyright © 1999 ATSG

Figure 25



FLUID LEVEL CHECK PROCEDURE

- (1) Transmission fluid level must be checked before performing the pressure tests and must be at normal operating temperature for accurate check. Drive vehicle if necessary to bring fluid temperature up to normal operating temperature of 82°C (180°F).
- (2) Position vehicle on flat level surface.
- (3) Start and run engine at curb idle speed.
- (4) **Apply Parking Brakes.**
- (5) Shift transmission through all gear ranges and then back to the Neutral position.
- (6) Remove dipstick and check fluid level.
 - (A) Correct level is in crosshatch area.
 - (B) Correct maximum level is to MAX arrow.
 - (C) Incorrect level is at or below MIN line.
- (7) If fluid level is low, add only enough of the Mopar® ATF Plus 3, Type 7176 to restore correct fluid level. Do not overfill (See Figure 26).

Dexron II fluid is NOT recommended. Clutch chatter can result from the use of improper fluid.

PRESSURE TEST LOCATIONS AND PROCEDURE

There are only two pressure taps supplied on the transmission case. The torque converter ON and torque converter OFF taps are located on the right side of the transmission case, shown in Figure 25.

There are two available methods to determine main line pressure. The DRB Scan Tool can be used to read main line pressure from the line pressure sensor. The 2nd method is to install Line Pressure Adapter 8259 into the transmission case, and re-install the line pressure sensor and the pressure gauge into the adapter, shown in Figure 25. This will allow a comparison of the DRB readings and the pressure gauge to determine the accuracy of the feedback to the controller. Refer to the chart in Figure 25 for proper pressure readings.

To access any of the other pressure tap locations, the transmission oil pan must be removed, the pressure taps removed from the valve body and the Valve Body Pressure Tap Adapter 8258 installed. Refer to Figure 12 on Page 16. The extensions supplied with Adapter 8258 will allow the installation of pressure gauges to the valve body to test individual clutch pack pressures. Refer to Figure 12 on Page 16 for pressure tap identification.

GENERAL OPERATION INFORMATION

The 45RFE transmission is a sophisticated, multi-range, electronically controlled transmission which combines optimized gear ratios for very responsive performance and state of the art efficiency. Features include driver adaptive shifting and three planetary gear sets to provide wide ratio capability with precise ratio steps to optimize driveability. The three planetary gear sets also make available a unique alternate 2nd gear ratio. The primary 2nd gear ratio falls between 1st and 3rd gears for normal upshifts on acceleration. The alternate 2nd gear ratio (2nd Prime) allows for a smoother 4-2 kickdown at high speeds to provide 2nd gear passing performance over a wider hi-way cruising range.

The 45RFE offers full electronic control of all automatic up and downshifts, and features real-time adaptive closed-loop shift and pressure control. Electronic shift and converter clutch controls help protect the transmission from damage due to high temperatures, which can occur under severe operating conditions.

The 45RFE also features a unique dual stage oil pump with electronic output pressure control. Under most driving conditions, pump output pressure greatly exceeds that which is needed to keep the clutches applied. The 45RFE pump pressure control system monitors input torque and adjusts the pump pressure accordingly. The primary stage of the pump works continuously. The second stage is by-passed when demand is low. The control system also monitors input and output speed and, if clutch slippage is observed, the pressure control solenoid duty cycle is varied, increasing pressure in proportion to demand.

PRIMARY MECHANICAL COMPONENTS

- **3 MULTIPLE DISC INPUT CLUTCHES**
- **3 MULTIPLE DISC HOLDING CLUTCHES**
- **3 PLANETARY GEAR SETS**
- **5 HYDRAULIC ACCUMULATORS**
- **DUAL STAGE HYDRAULIC OIL PUMP**
- **VALVE BODY**
- **TRANSMISSION RANGE SENSOR/SOLENOID PACK**

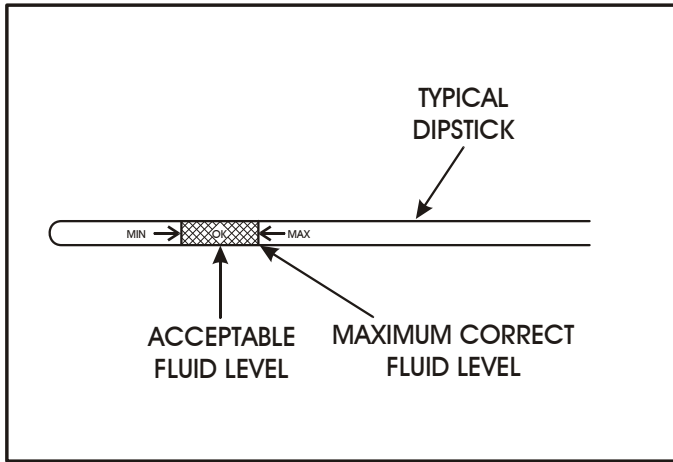

Figure 26

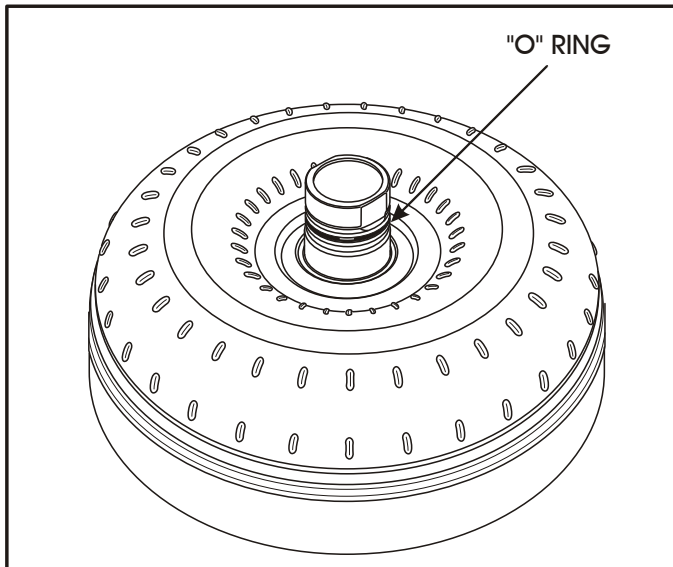

Figure 27

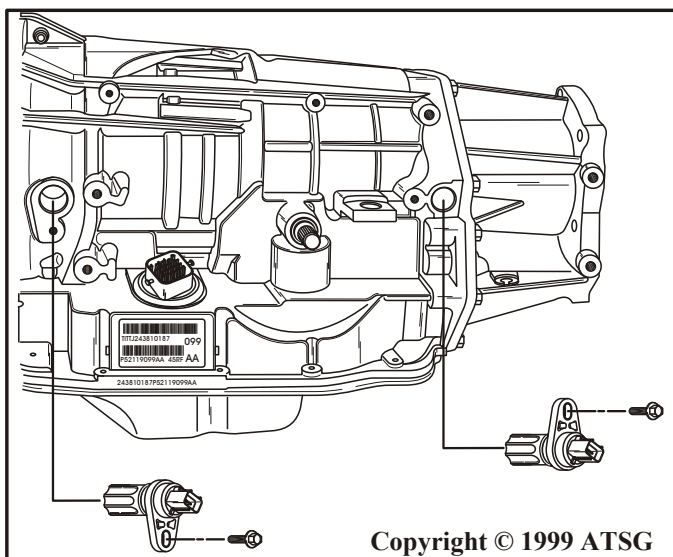

Figure 28

TRANSMISSION DISASSEMBLY

1. Drain fluid from the transmission.
2. Clean exterior of the transmission thoroughly with a suitable solvent or pressure washer.
3. Remove the torque converter from the transmission, remove and discard the "O" ring from the converter hub (See Figure 27).
4. Remove the manual shift lever.
5. Remove both input and output speed sensors from the case, as shown in Figure 28, remove and discard both "O" rings.
6. Remove the line pressure sensor from the case, as shown in Figure 29, remove and discard the "O" rings.
7. Remove the 12 extension housing to case retaining bolts using a 15mm socket and then remove extension housing (See Figure 30).
8. Remove the park gear snap ring from output shaft and remove park gear (See Figure 30).
9. Using a dial indicator, measure and record the output shaft end-play reading.
10. Using a dial indicator, measure and record the input shaft end-play reading.

NOTE: When measuring the input shaft end-play, two "stops" will be felt. When the input shaft is pushed inward and the indicator zeroed, the first stop felt when the input shaft is pulled outward is the movement of the input shaft in the input clutch hub. This value should not be included in the end-play measurement and therefore must be recorded and subtracted from the total dial indicator reading.

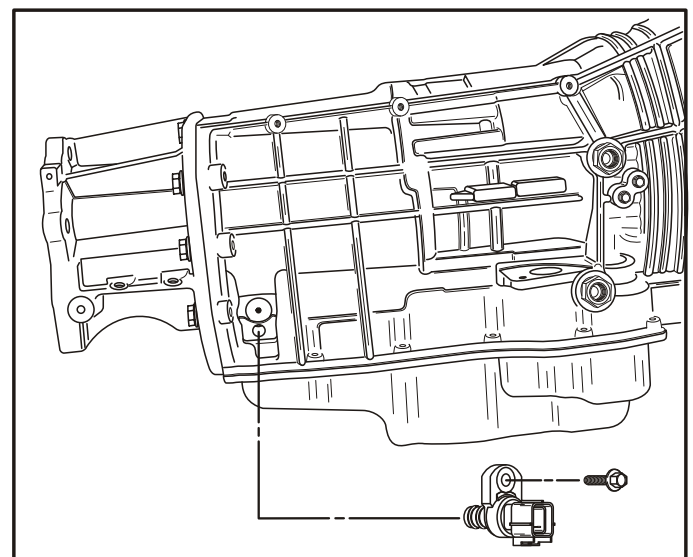

Figure 29

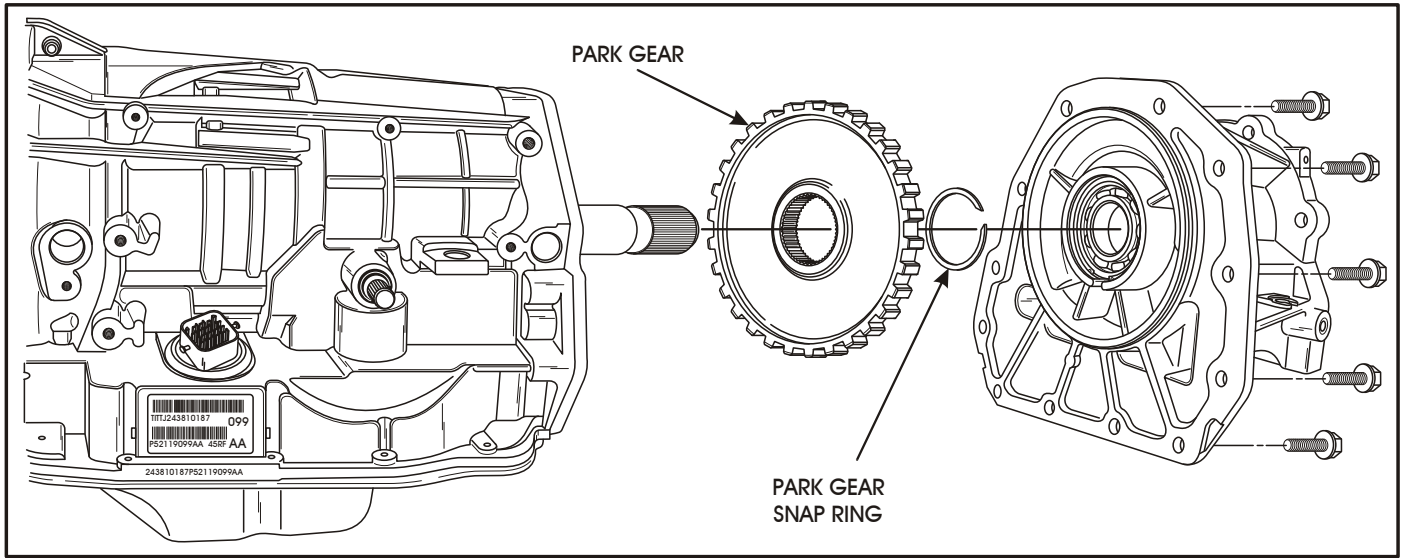

Figure 30

10. Remove the 15 bottom pan bolts, using an 8mm socket, as shown in Figure 31.
11. Remove bottom oil pan as shown in Figure 31.

NOTE: This unit uses no gaskets anywhere. The extension housing and bottom pan are sealed with RTV.

12. Remove the bottom pan filter retaining screw, using a 25 Torx bit (See Figure 32).
13. Remove and discard the bottom pan oil filter, as shown in Figure 32.

Continued on next Page.

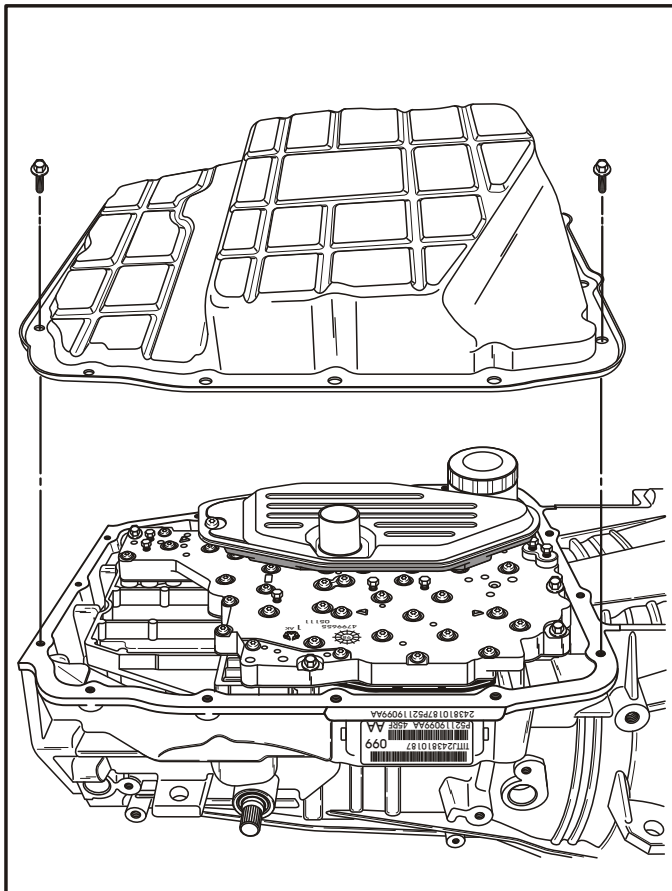

Figure 31

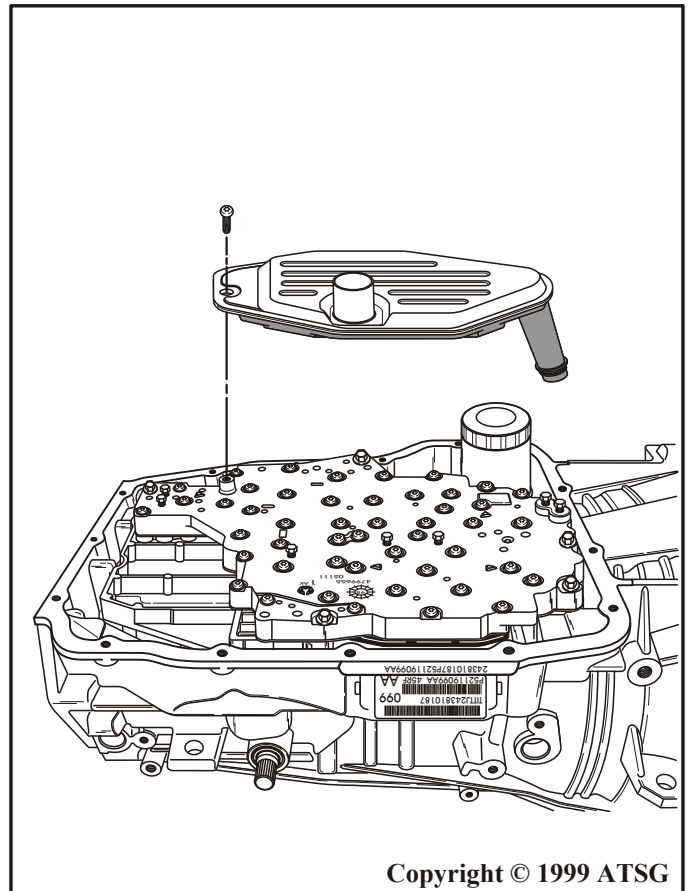

Figure 32

Copyright © 1999 ATSG

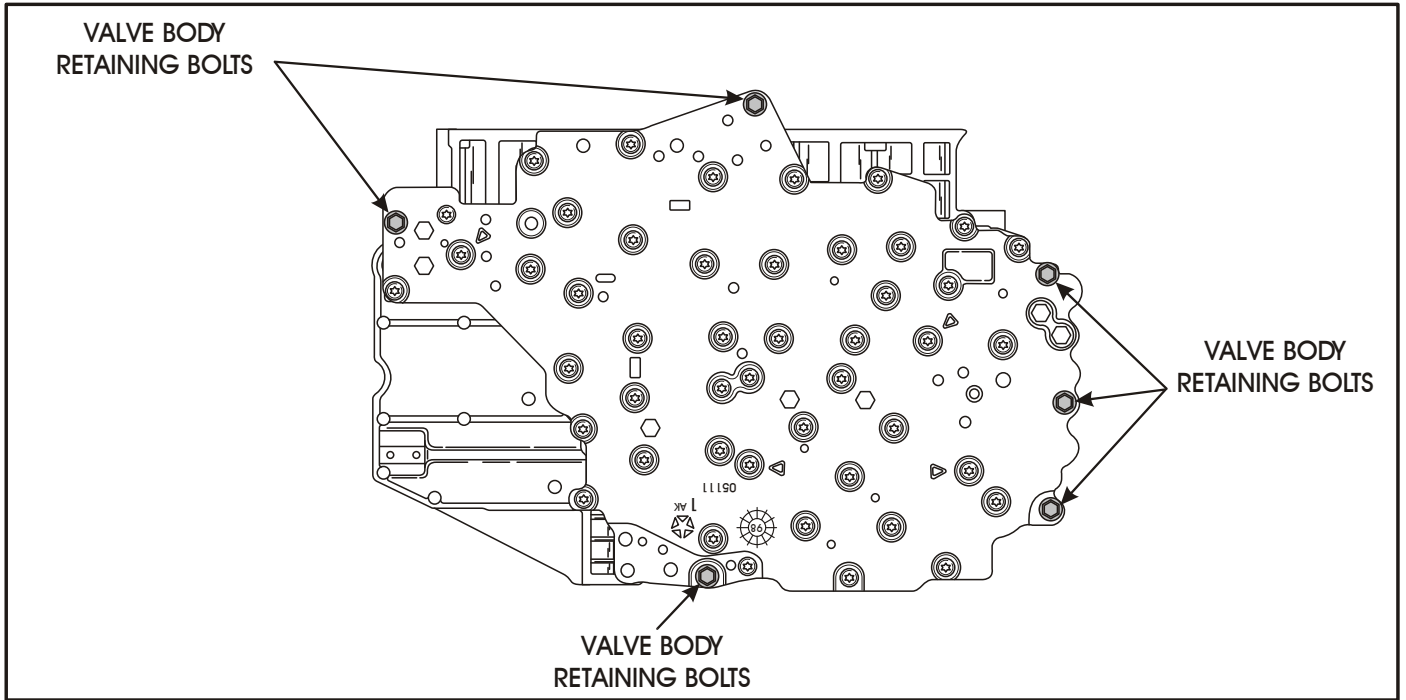

Figure 33

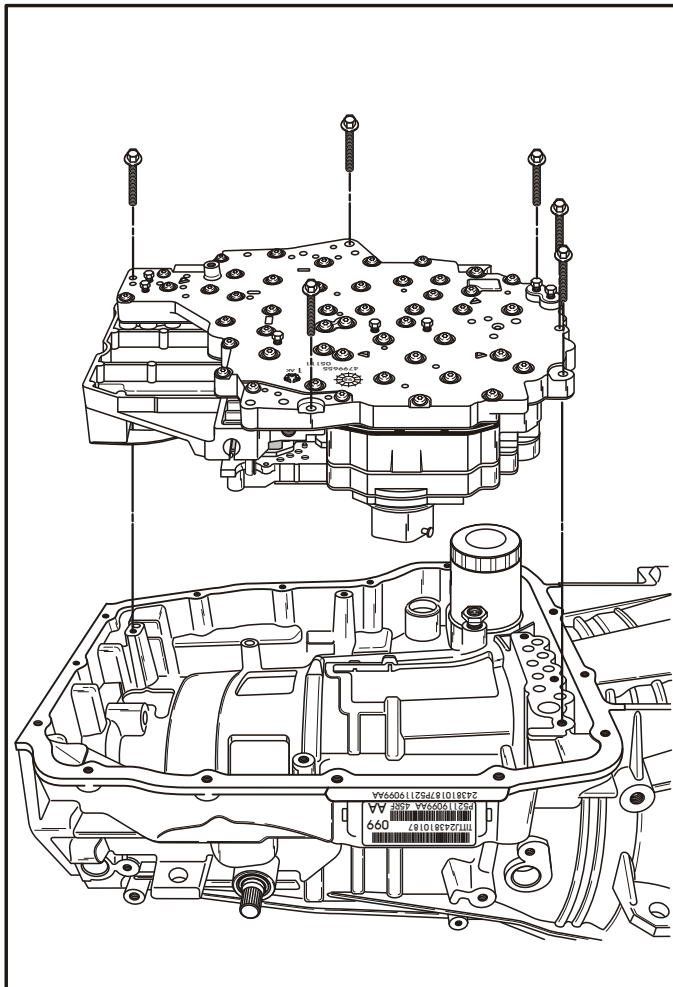

Figure 34

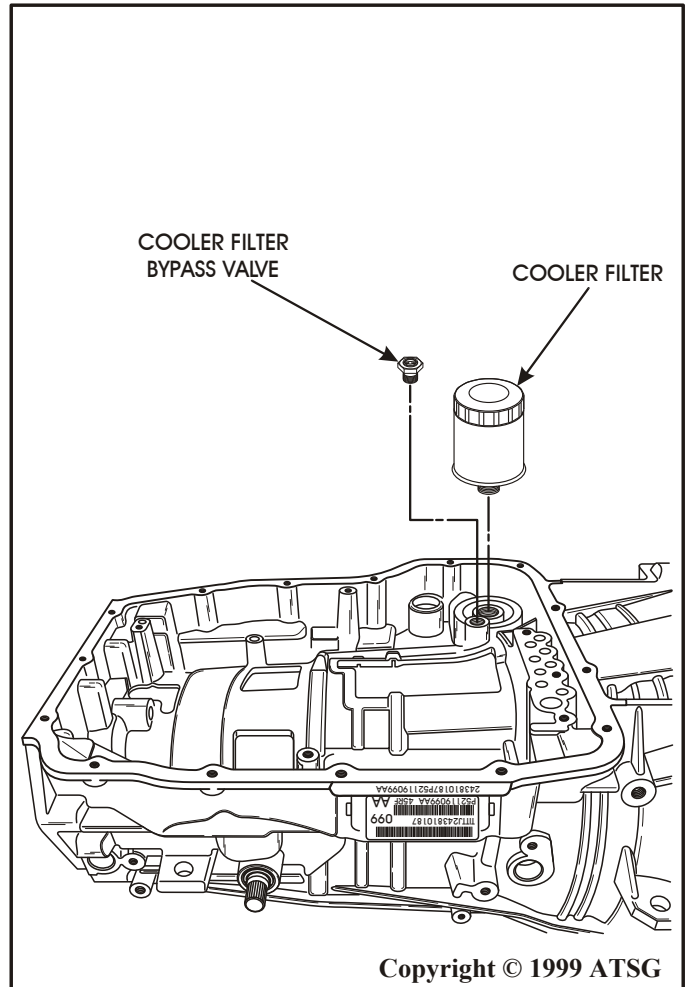

Figure 35

Copyright © 1999 ATSG

14. Remove the six valve body retaining bolts that are illustrated in Figure 33, using 8mm socket.
15. Remove the complete valve body and the TRS/Solenoid body as an assembly as shown in Figure 34, and set aside for component disassembly.
16. Remove and discard the cooler oil filter from the transmission case as shown in Figure 35.
17. Remove the cooler by-pass valve from case, as shown in Figure 35.
18. Remove the outer snap ring retaining the transmission front cover in the transmission case as shown in Figure 36.
19. Remove the inner snap ring retaining the front cover to the oil pump as shown in Figure 36.
20. Reach through one of the case openings in the valve body area with a long blunted tool, and tap the transmission front cover from the case. Refer to Figure 36.
21. Remove the six bolts retaining the oil pump in the transmission case (See Figure 36).
22. Remove the oil pump from the transmission. Hold down on the input shaft to prevent the input clutch housing assembly from coming out with the oil pump (See Figure 36).
23. Set the oil pump assembly aside for component disassembly.

Continued on next Page.

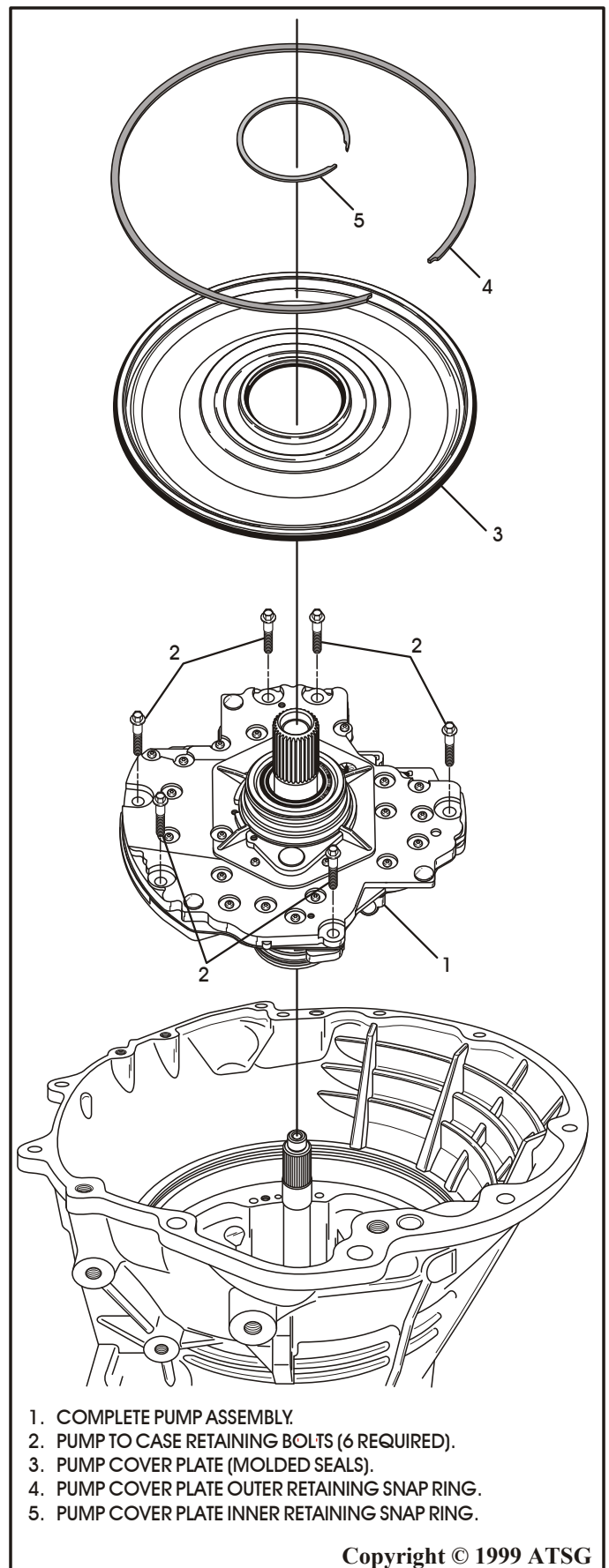
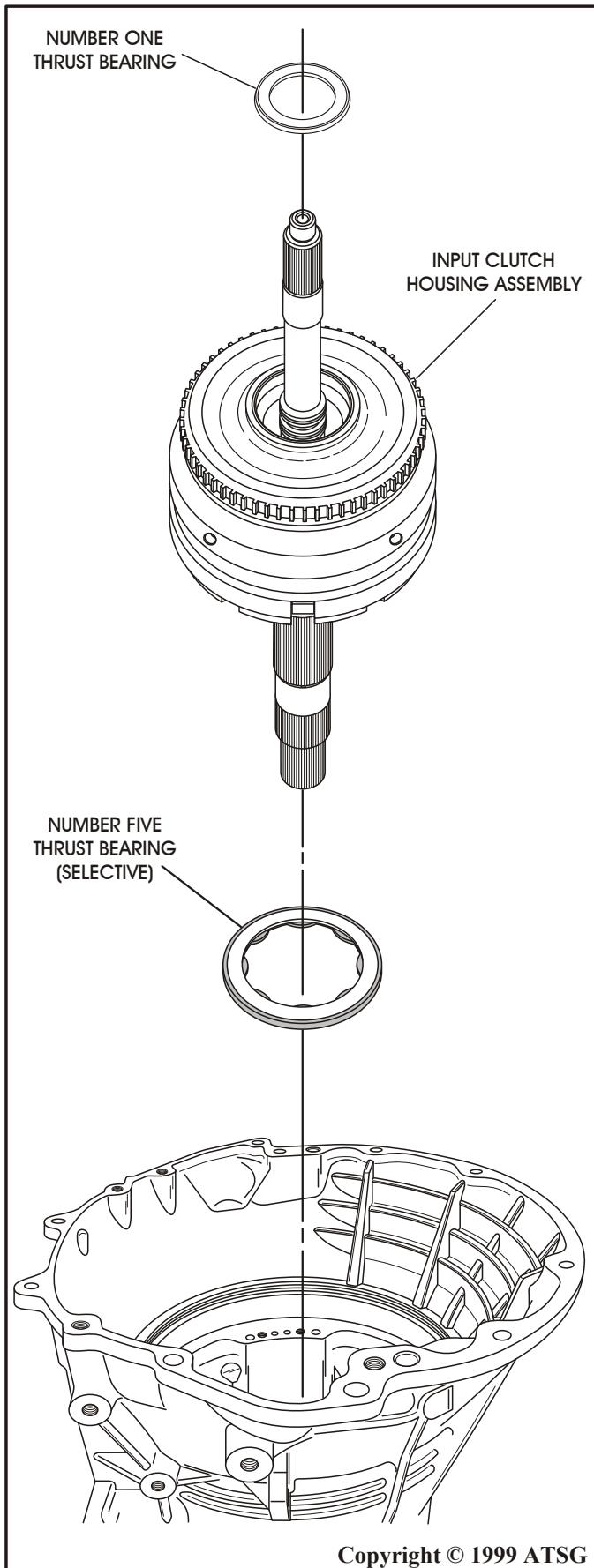

Figure 36



Copyright © 1999 ATSG

Figure 37

24. Remove the input clutch housing assembly by lifting straight up as shown in Figure 37.
25. Remove the number one thrust bearing from inside the input housing as shown in Figure 37.
26. Remove the number 5 *selective* thrust bearing from back side of the input housing, or from the 2-4 support in transmission (See Figure 37).
27. Set the input clutch housing assembly aside for component disassembly.
28. Remove the 2-4 clutch retainer front snap ring, which is a *tapered* snap ring, from transmission case as shown in Figure 38.
29. Remove the 2-4 clutch retainer from the transmission case, as shown in Figure 38, and set aside for component disassembly.
30. Remove the 2-4 clutch retainer rear snap ring, which is a *flat* snap ring, from the transmission case as shown in Figure 38.
31. Remove the 2nd clutch pack, 2 steel plates and 2 friction plates, from the transmission case as shown in Figure 39.
32. Remove the 2nd clutch pressure plate from the transmission case as shown in Figure 39.

Continued on Page 38.

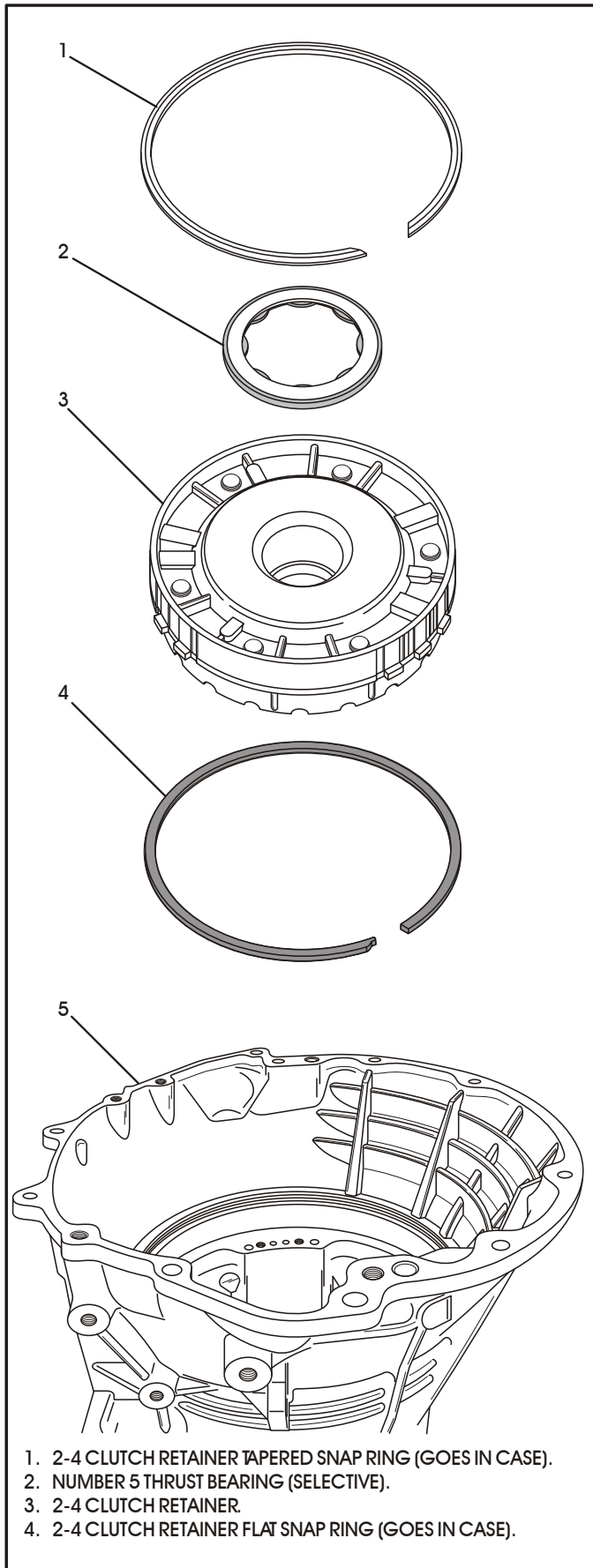

Figure 38

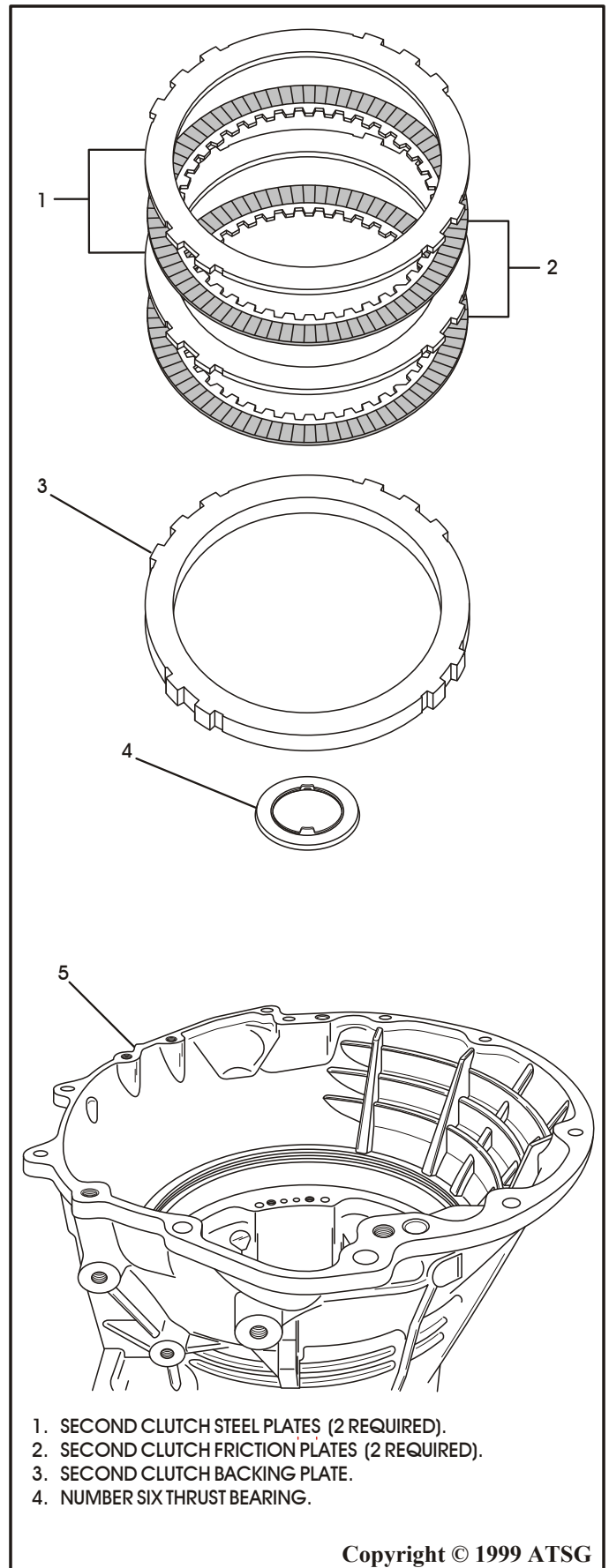

Figure 39

Copyright © 1999 ATSG

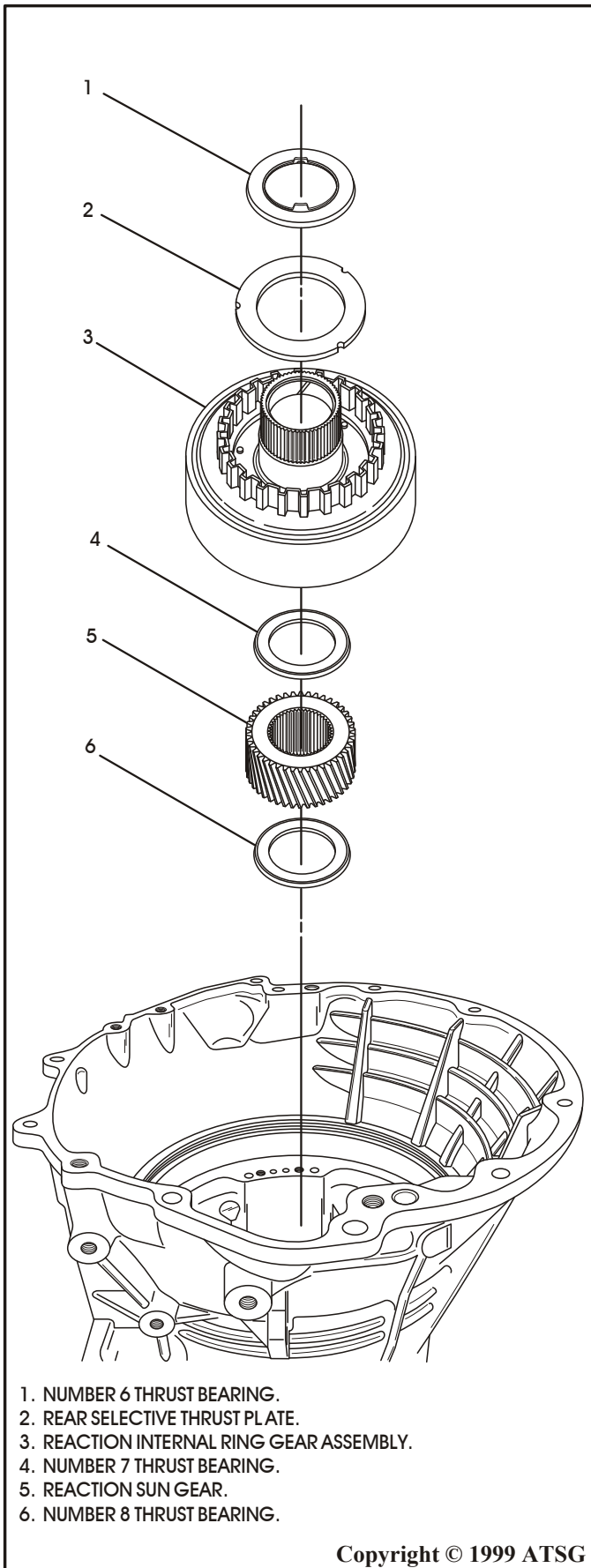

Figure 40

33. Remove the number 6 thrust bearing if it is present. It may have been stuck to the 2-4 retainer (See Figure 40).
34. Remove the rear selective plate as shown in Figure 40.
35. Remove reaction internal ring gear assembly as shown in Figure 40.
36. Remove the number 7 thrust bearing as shown in Figure 40.
37. Remove the reaction sun gear as shown in Figure 40.
38. Remove the number 8 thrust bearing as shown in Figure 40.
39. Remove the reaction carrier/reverse sun gear assembly as shown in Figure 41.
40. Remove the number 9 thrust bearing as shown in Figure 41.

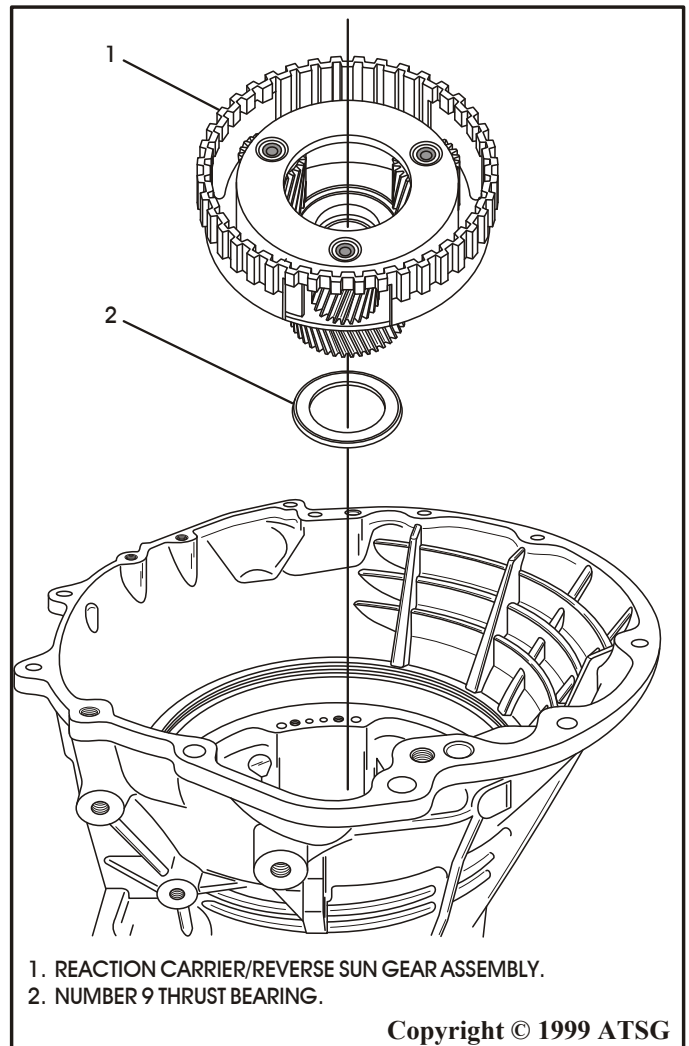

Figure 41

41. Remove reverse carrier/input ring gear "flat" snap ring from the input internal ring gear as shown in Figure 42.
42. Remove the reverse carrier/input ring gear assembly as shown in Figure 42.
43. Remove the number 10 thrust bearing assembly as shown in Figure 42.
44. Remove the input sun gear assembly as shown in Figure 43.
45. Remove the number 11 thrust bearing as shown in Figure 43.
46. Remove the input planetary carrier/reverse internal ring gear as shown in Figure 43.

Continued on Page 40.

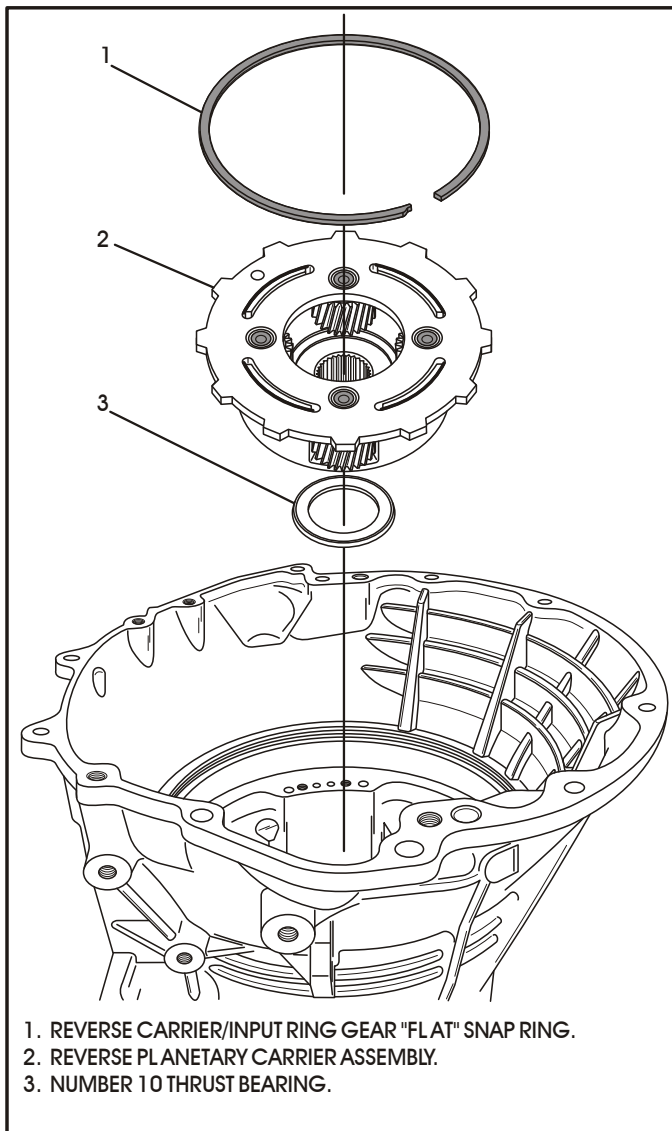

Figure 42

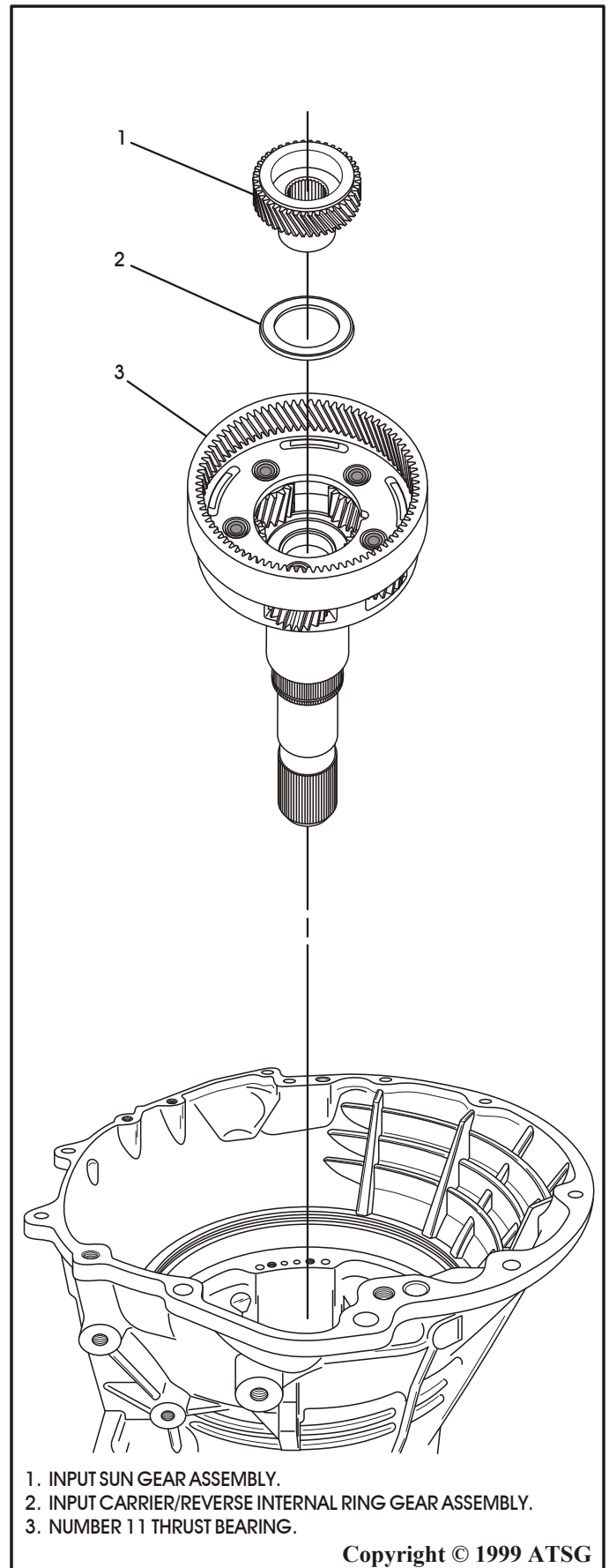

Figure 43

47. Remove the input internal ring gear assembly from the transmission case (See Figure 44).
48. Remove the number 12 thrust bearing from the low/reverse clutch housing assembly as shown in Figure 44.
49. Remove the "Tapered" snap ring from the case that retains the low/reverse clutch housing in transmission case (See Figure 45).
50. Remove low/reverse clutch housing assembly from the transmission case by lifting straight up, as shown in Figure 45, and set aside for component disassembly.

51. Remove the park rod retaining "E" clip from the manual lever as shown in Figures 46 & 47.
52. Remove the park rod from the transmission as shown in Figures 46 and 47.
53. Remove the manual shaft and lever assembly retaining pin bolt using a 30 Torx bit as shown in Figures 46 and 47.
54. Remove the manual shaft and lever assembly through the inside of the case. Refer to Figures 46 and 47.
55. Remove and discard the manual shaft seal as shown in Figure 47.

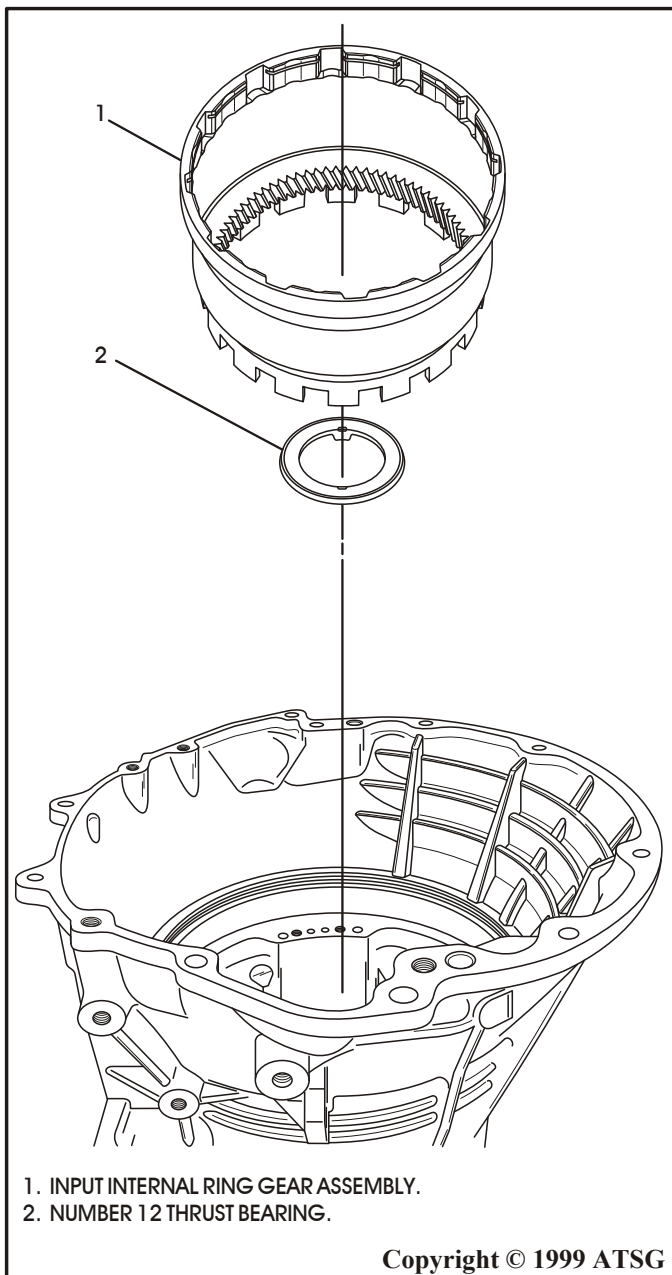

Figure 44

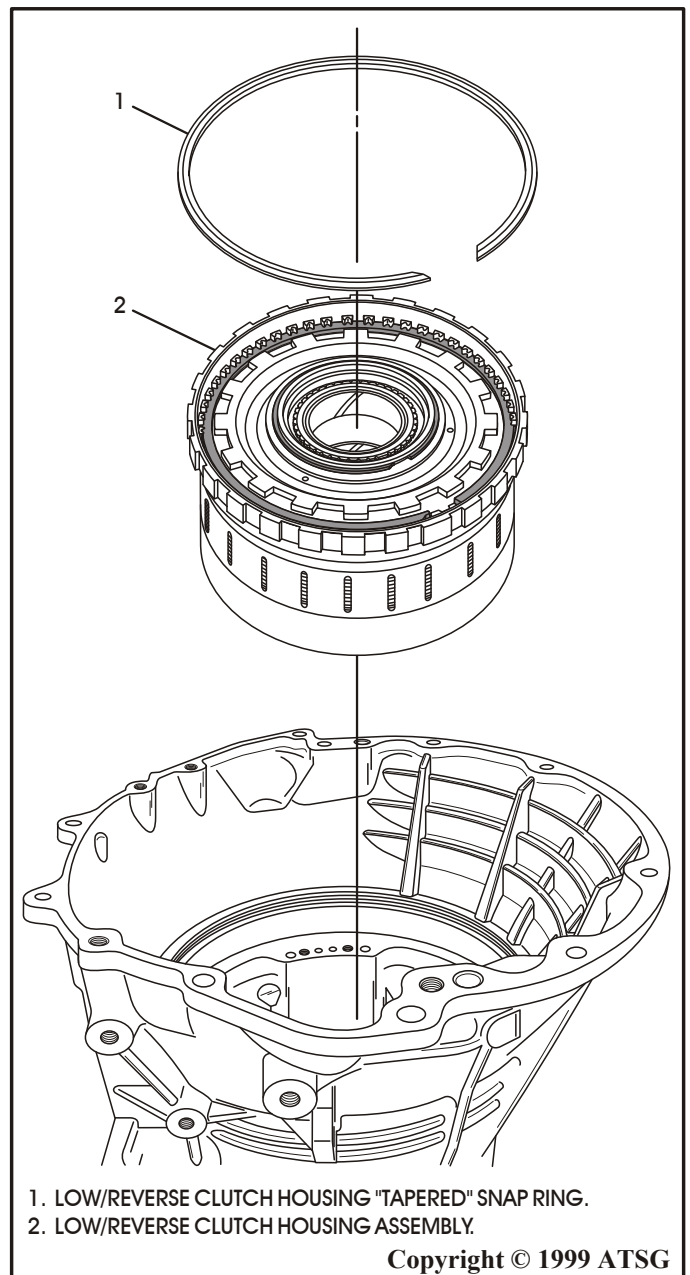

Figure 45

56. Remove the park rod guide retaining snap ring from the case as shown in Figure 47.
57. Remove the park rod guide from the case, as shown in Figure 47.

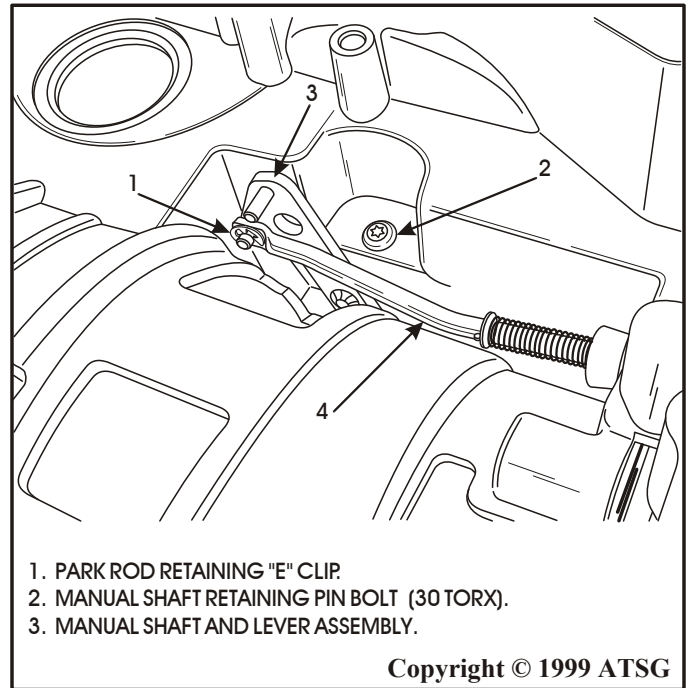

Figure 46

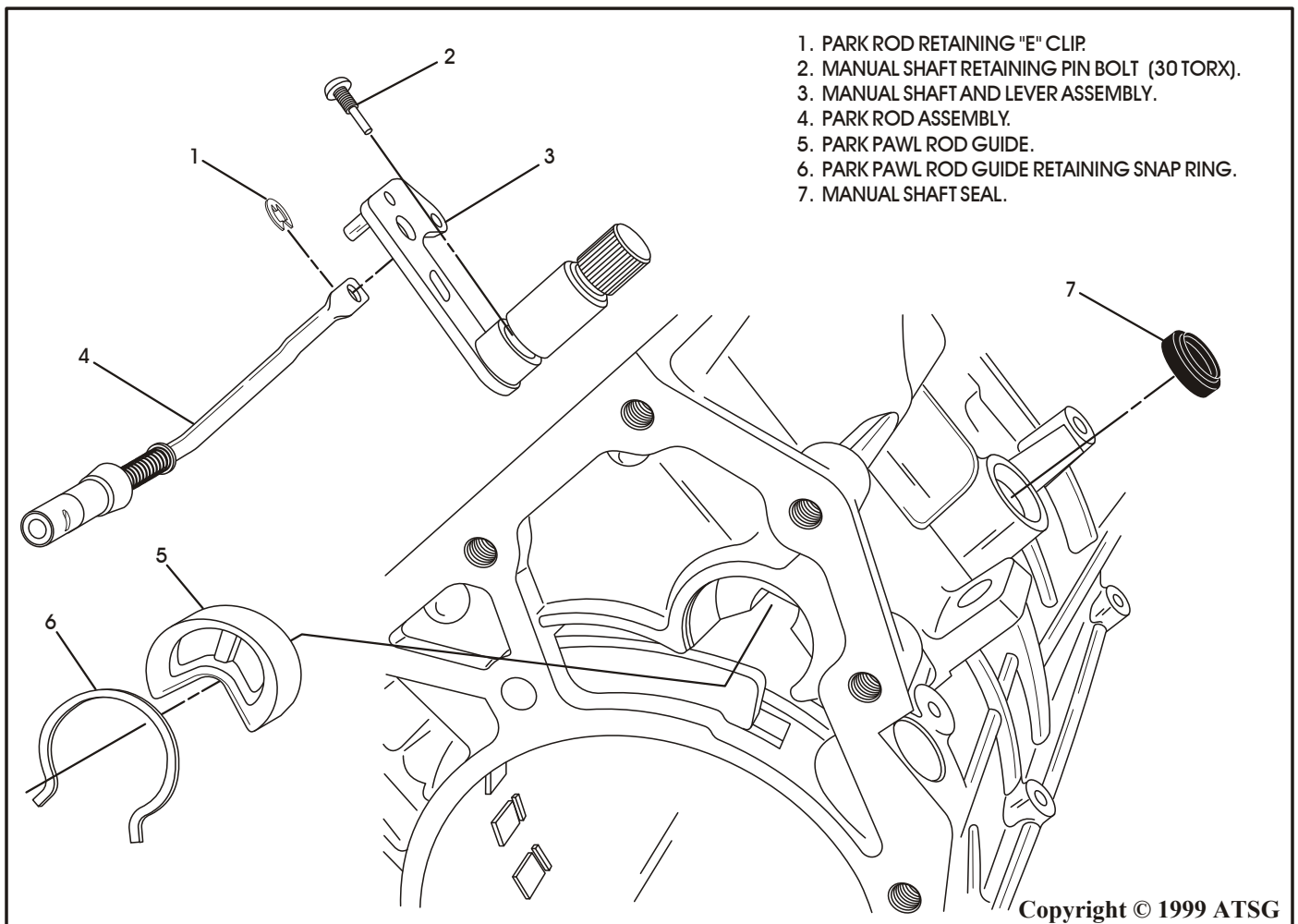

Figure 47

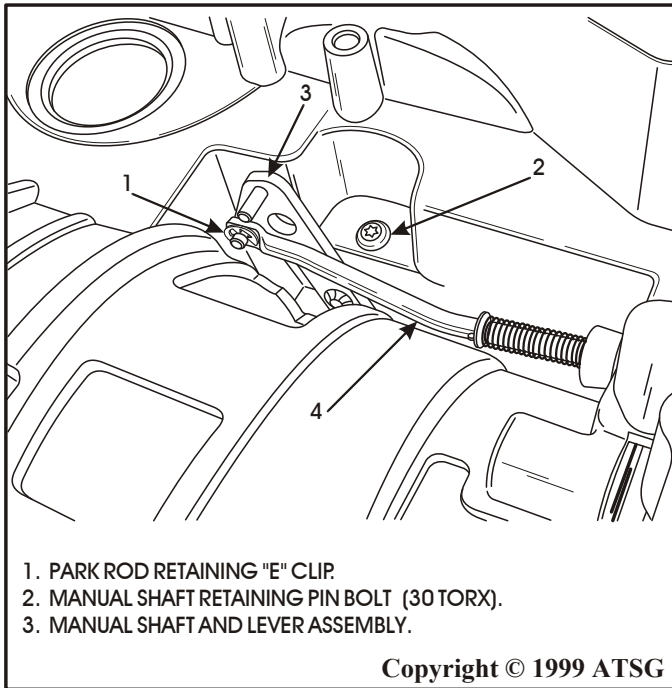

Figure 48

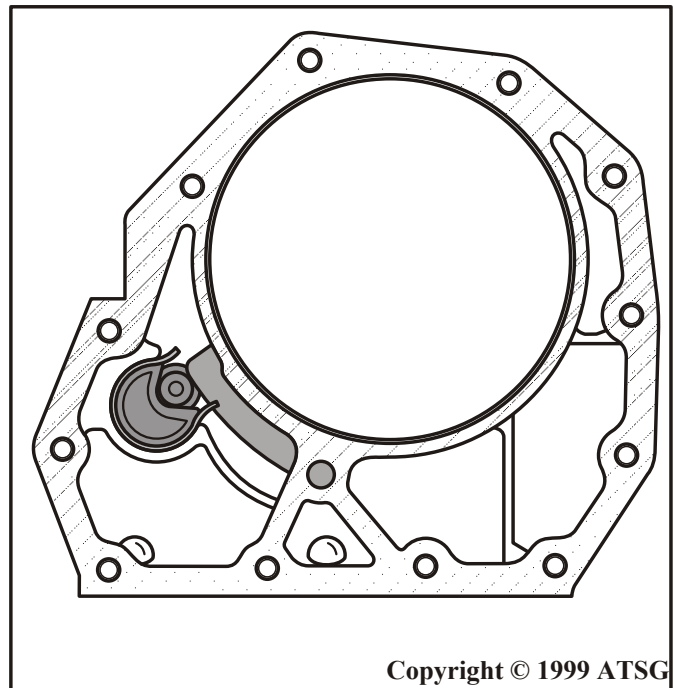

Figure 49

COMPONENT REBUILD

TRANSMISSION CASE ASSEMBLY

1. Clean and inspect all components. Replace any parts which show evidence of damage or wear.
2. Install the park rod guide into the transmission case, as shown in Figure 47.
3. Install the park rod guide retaining snap ring into the case using a pair of pliers and insure that it is seated in the groove (See Figure 49).
4. Install a new manual shaft seal into the case using the proper size seal driver and insure that it is fully seated in bore (See Figure 47).
5. Lubricate the manual shaft lever seal with a small amount of TransJel®.
6. Install the manual shaft and lever assembly through the inside of case and into the manual shaft case bore as shown in Figure 47.
7. Install the manual shaft and lever assembly retaining pin bolt, using a 30 Torx bit, torque to 28.2 Nm (250 in lbs). (See Figure 48)
8. Install park rod through park rod guide and the parking pawl, and onto the pin on manual lever. Refer to Figures 48 and 49.
9. Install the retaining "E" clip and insure that it is fully seated as shown in Figure 48.
10. Ensure that the parking linkage works freely and set case aside for final assembly.

LOW/REVERSE CLUTCH HOUSING ASSEMBLY

1. Remove the inner overrunning clutch snap ring from the low/reverse clutch housing. This snap ring is item 16 in Figure 50.
2. Remove the outer low/reverse backing plate snap ring from the low/reverse clutch housing. This snap ring is item 11 in Figure 50.
3. Remove the low/reverse clutch pack and the low overrun clutch assembly together as an assembly (See Figure 50).
4. Separate the low/reverse clutch pack from the low overrun clutch assembly.
5. Remove the overrun clutch snap ring from the inner race. This snap ring is item 15 in Figure 50.
6. Remove the spacer washer from the overrun clutch assembly, item 16 in Figure 50.
7. Separate the inner and outer races of overrun clutch assembly.
8. Remove the lower overrun clutch snap ring from the low/reverse clutch housing, item 7 in Figure 50.
9. Using a suitable shop press, compress the low reverse bellville plate and remove the "split" retaining ring, remove the bellville plate and the piston from housing (See Figure 50).
10. Remove and discard both piston seals.

Continued on Page 44.

LOW/REVERSE CLUTCH HOUSING EXPLODED VIEW

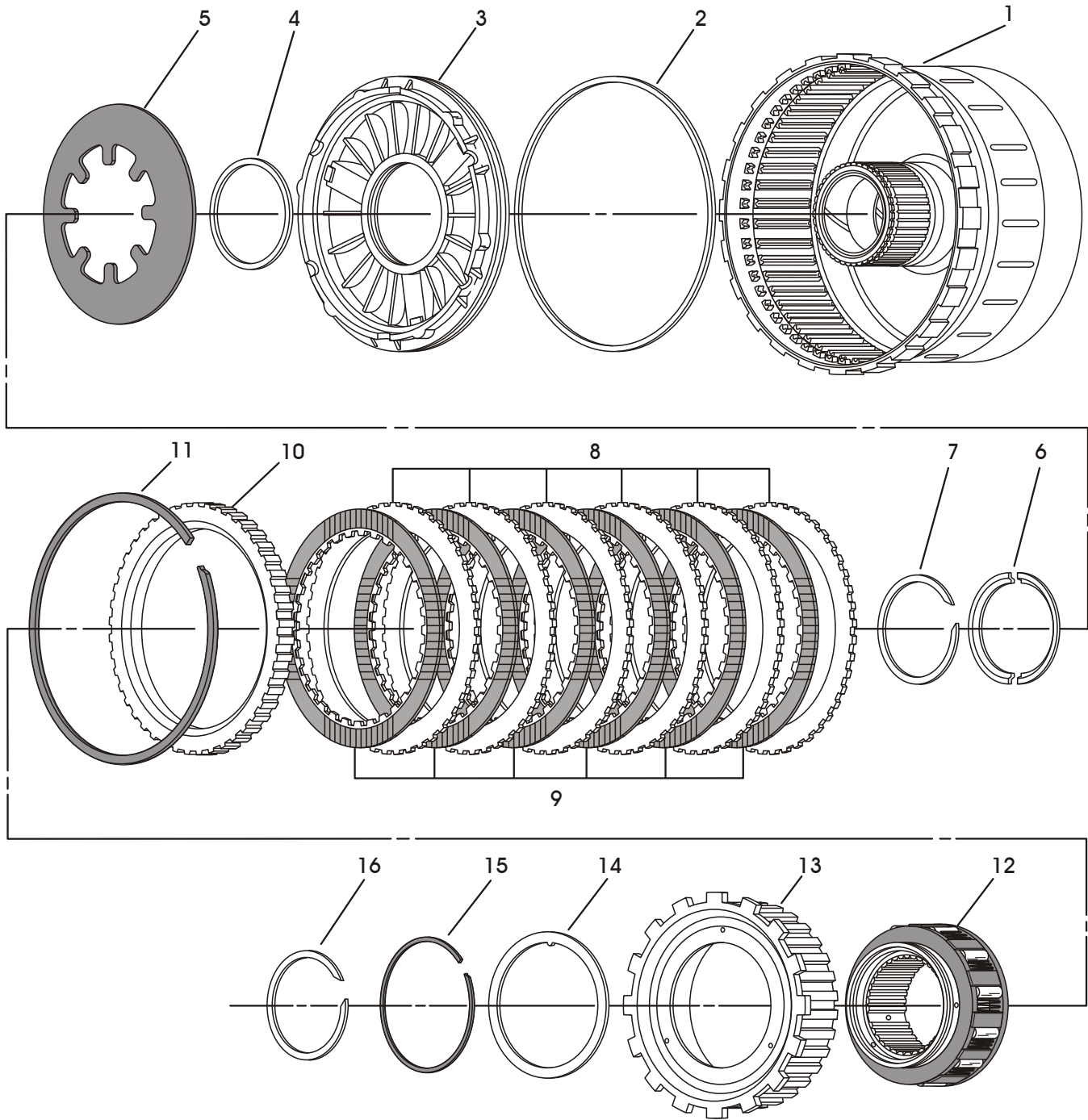

- | | |
|--|--|
| <ul style="list-style-type: none"> 1. LOW/REVERSE CLUTCH HOUSING 2. LOW/REVERSE CLUTCH PISTON OUTER "D" RING 3. LOW/REVERSE CLUTCH PISTON 4. LOW/REVERSE CLUTCH PISTON INNER "D" RING 5. LOW/REVERSE CLUTCH BELLVILLE PLATE 6. LOW/REVERSE BELLVILLE PLATE "SPLIT" RETAINING RING 7. LOW ROLLER CLUTCH LOWER SNAP RING 8. LOW/REVERSE CLUTCH STEEL PLATES (6 REQUIRED) | <ul style="list-style-type: none"> 9. LOW/REVERSE CLUTCH FRICTION PLATES (6 REQUIRED) 10. LOW/REVERSE CLUTCH BACKING PLATE 11. LOW/REVERSE CLUTCH BACKING PLATE SNAP RING 12. LOW ROLLER CLUTCH AND INNER RACE ASSEMBLY 13. LOW ROLLER CLUTCH OUTER RACE 14. SPACER WASHER 15. LOW ROLLER INNER RACE RETAINING SNAP RING 16. LOW ROLLER CLUTCH UPPER SNAP RING |
|--|--|

Copyright © 1999 ATSG

Figure 50

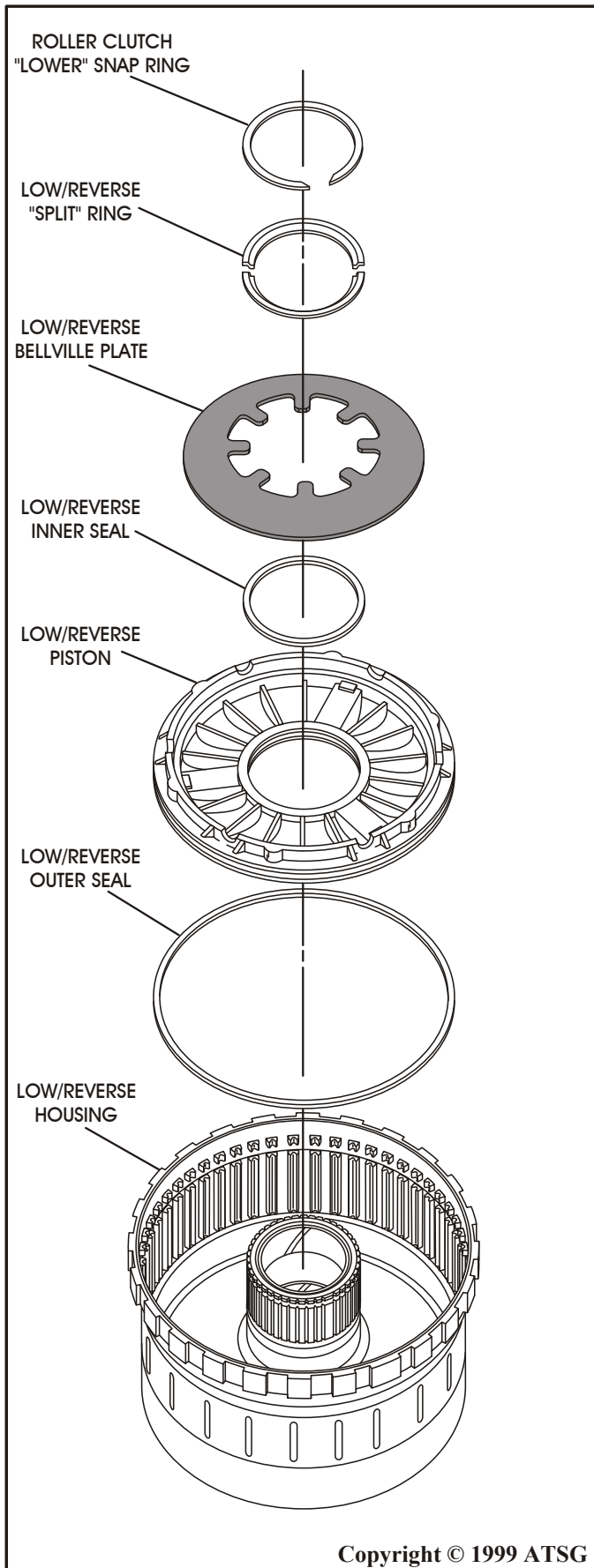

Figure 51

LOW/REVERSE CLUTCH HOUSING ASSEMBLY (Cont'd)

1. Clean and inspect all low/reverse clutch parts. Replace any components that show evidence of wear or damage.
2. Check the bleed orifice in the bottom of the low/reverse clutch housing to ensure that it is not plugged or restricted (See Figure 52).
3. Install new inner and outer seals onto the low reverse piston and lubricate with small amount of TransJel® (See Figure 51).
4. Install the low/reverse piston assembly into the low/reverse clutch housing (See Figure 51).
5. Install the bellville plate on top of the piston as shown in Figure 51.
6. Compress the low/reverse piston bellville plate and install the split retaining ring to hold the bellville spring in the clutch housing. Refer to Figures 51 and 53.
7. Install the "lower" overrunning clutch snap ring into the groove directly above the split ring in the low/reverse clutch housing.
8. Install the inner race into the outer race. While holding the inner race, rotate the outer race in a clockwise direction to install (See Figure 55).
9. Install the spacer washer on top of the outer race as shown in Figure 55.
10. Install the low roller clutch inner race retaining snap ring into the groove above the spacer as shown in Figure 54 and 55.

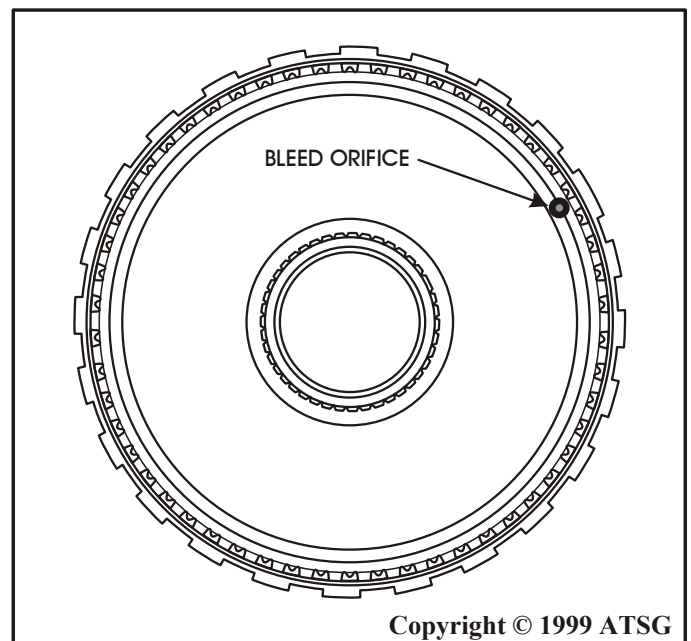

Figure 52

11. Check for proper low roller clutch operation, and set aside for installation after clutch plates are installed.

NOTE: When the low roller clutch is properly assembled the outer race should freewheel in a clock-wise direction while holding the inner race.

We have provided you with a snap ring chart with demensions to identify all snap rings in the Low/Reverse clutch housing in Figure 58.

Continued on Page 46.

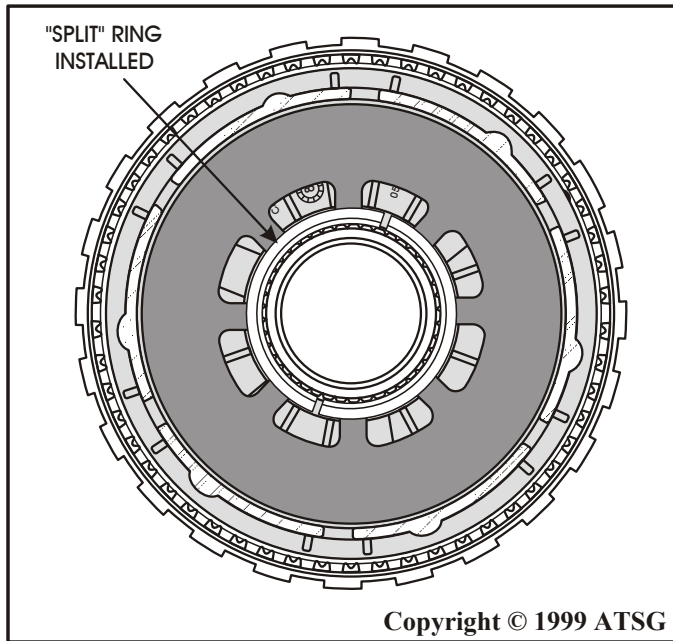

Figure 53

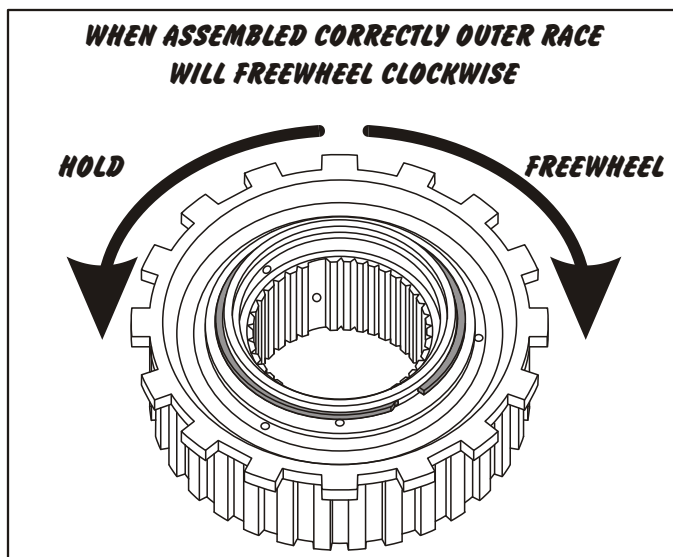

Figure 54

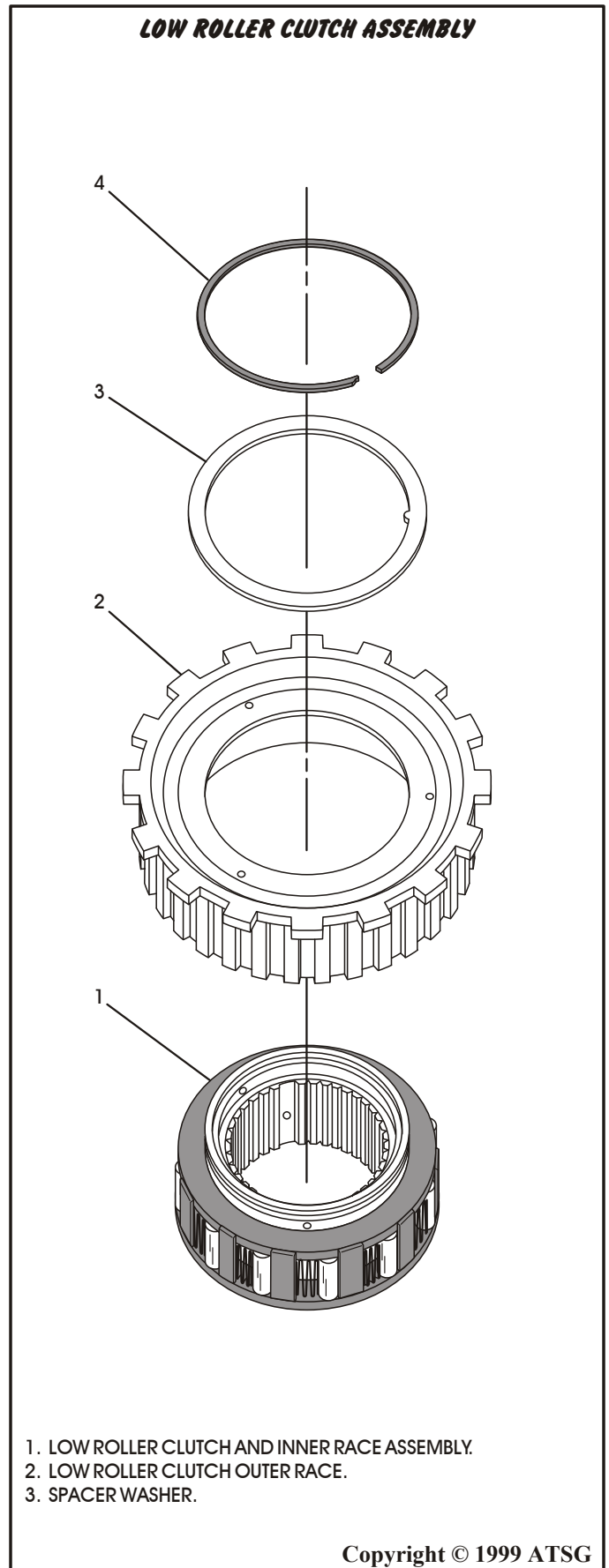

Figure 55

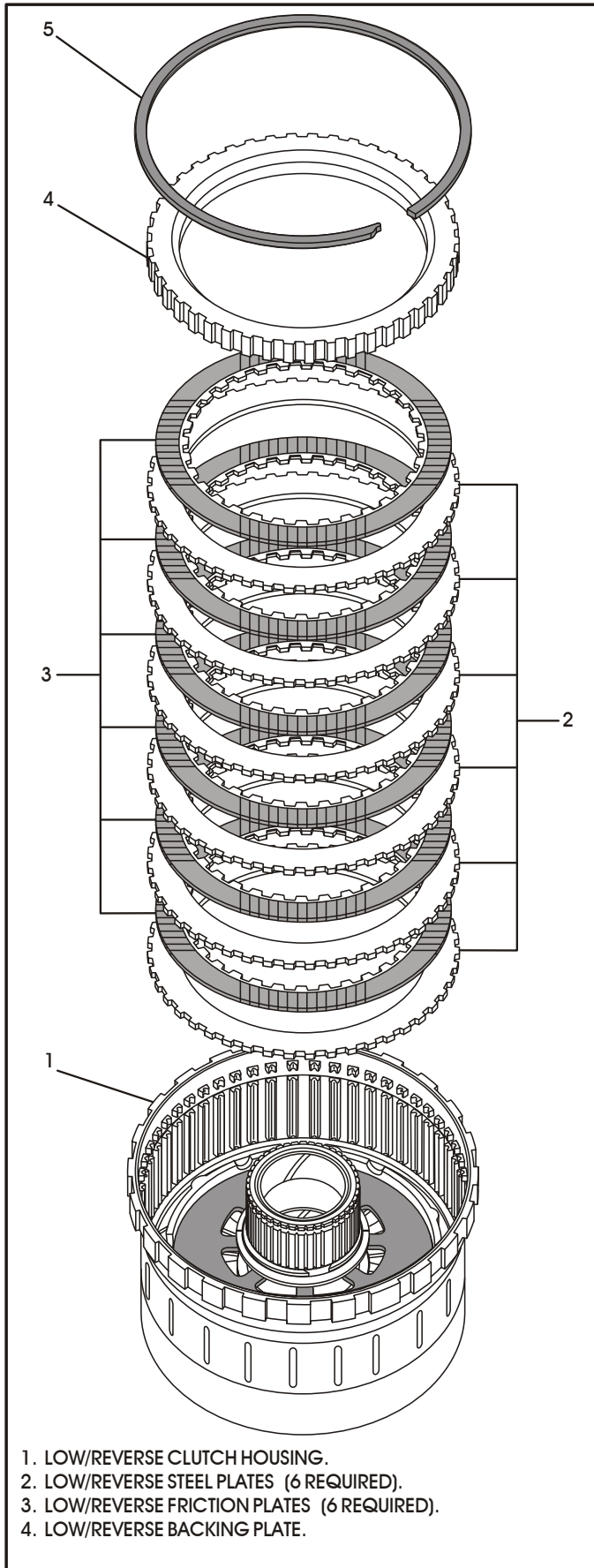

Figure 56

LOW/REVERSE CLUTCH HOUSING ASSEMBLY (Cont'd)

12. Install the low/reverse clutch pack beginning with a steel plate and alternating with a friction plate, until you have installed six of each, as shown in Figure 56.
13. Install the low/reverse backing plate with the inside bevel facing up as shown in Figure 56.
14. Install the low/reverse backing plate snap ring as shown in Figure 56. This is a selective snap ring to adjust clutch clearance.
15. Low/reverse clutch clearance should measure 1.14-1.91 mm (.045"-.075").

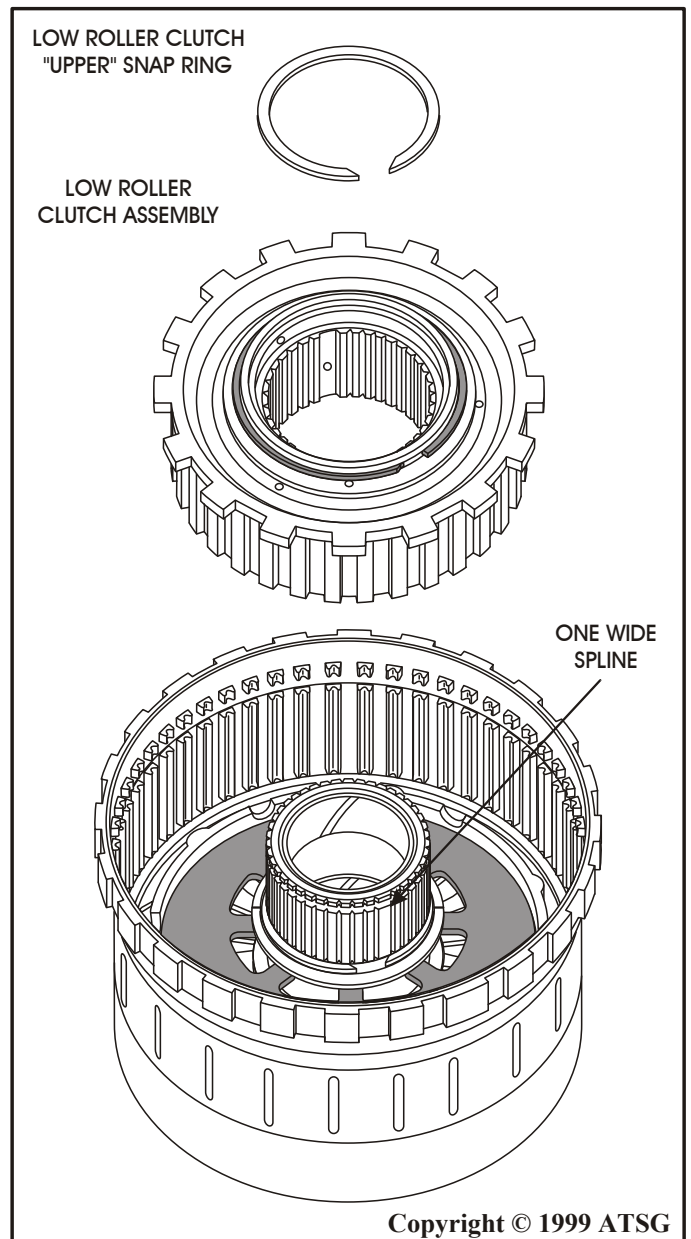
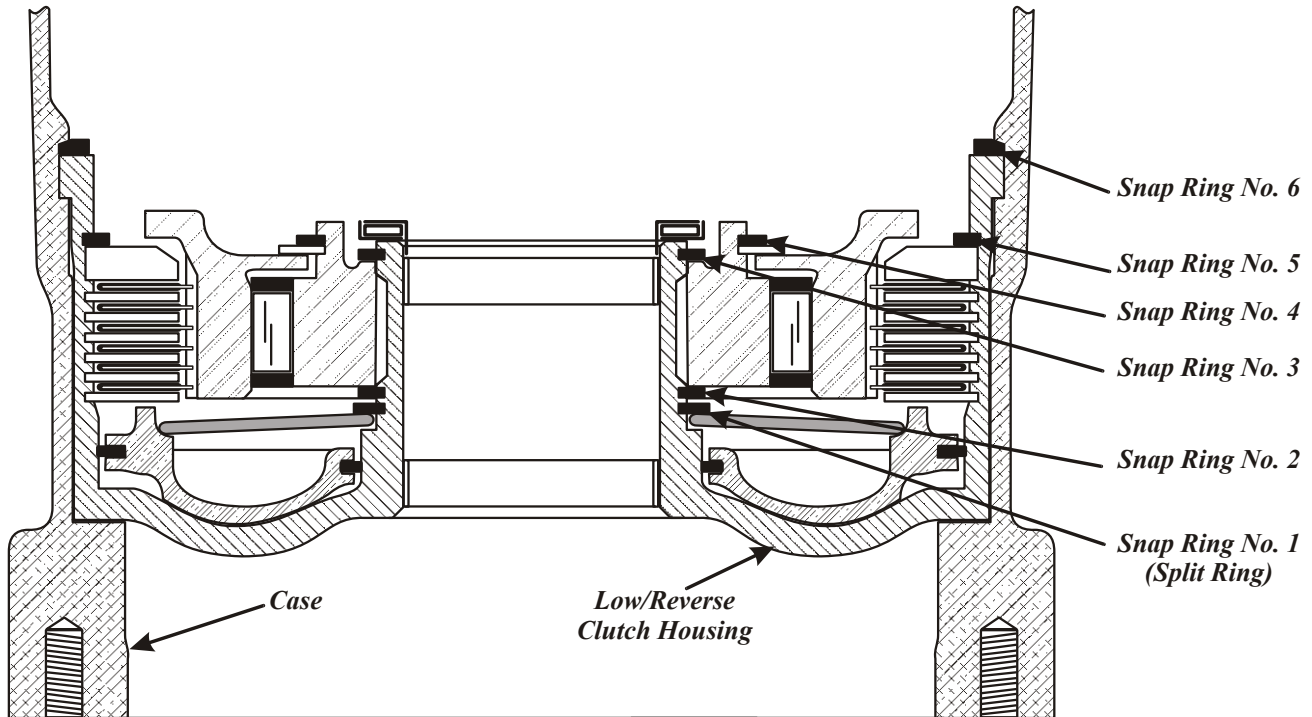

Figure 57

LOW/REVERSE CLUTCH HOUSING SNAP RING IDENTIFICATION

	Thickness	I.D. to O.D.	Notes:
Snap Ring No. 1	"Split" Ring		
Snap Ring No. 2	Flat .061"	.154"	
Snap Ring No. 3	Flat .061"	.154"	Same as Ring No. 2.
Snap Ring No. 4	Flat .038"	.187"	
Snap Ring No. 5	Flat .080"	.186"	
Snap Ring No. 6	Tapered .080"	.188"	Retains the housing in case.



Copyright © 1999 ATSG

Figure 58

16. Install the low roller clutch assembly into the low/reverse clutch housing by rotating outer race clockwise to engage each of the friction plates until it is fully seated.
17. The low/reverse clutch housing has one wider spline on the inner hub where the inner race splines to it, and the inner race must be turned to engage the splines (See Figure 57). This is done to ensure alignment of the lube holes.
18. After the low roller clutch assembly is fully seated, install the "upper" overrun clutch snap ring into the groove (See Figure 57).
19. Set the completed low/reverse clutch housing aside for final assembly (See Figure 59).

COMPLETED LOW/REVERSE CLUTCH HOUSING

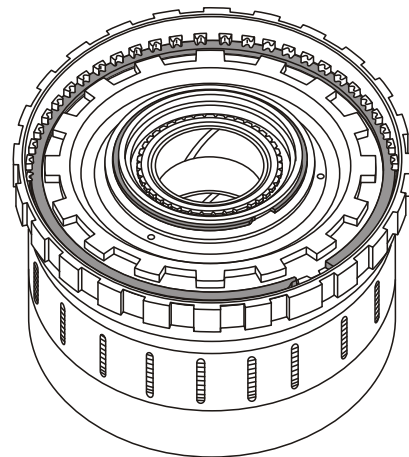

Copyright © 1999 ATSG

Figure 59

2-4 CLUTCH RETAINER EXPLODED VIEW

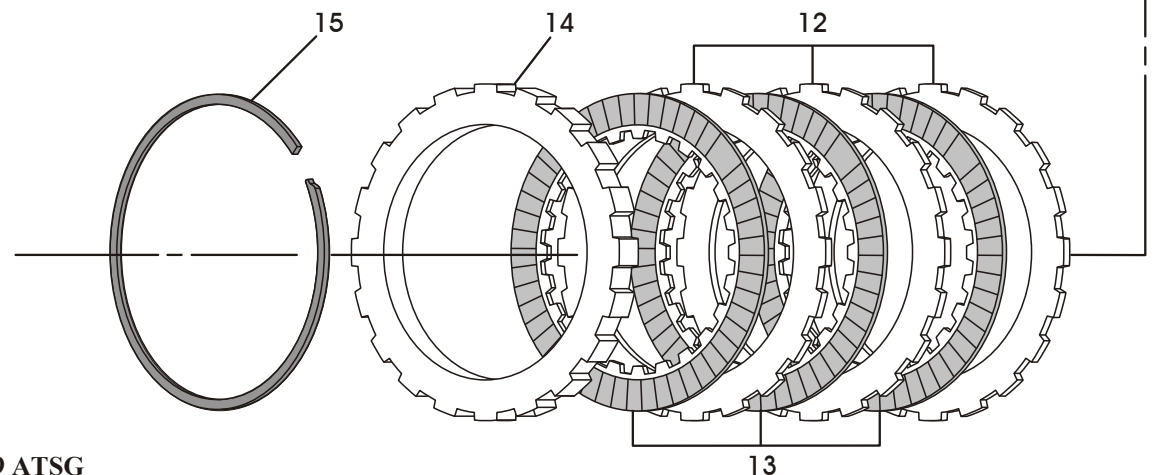
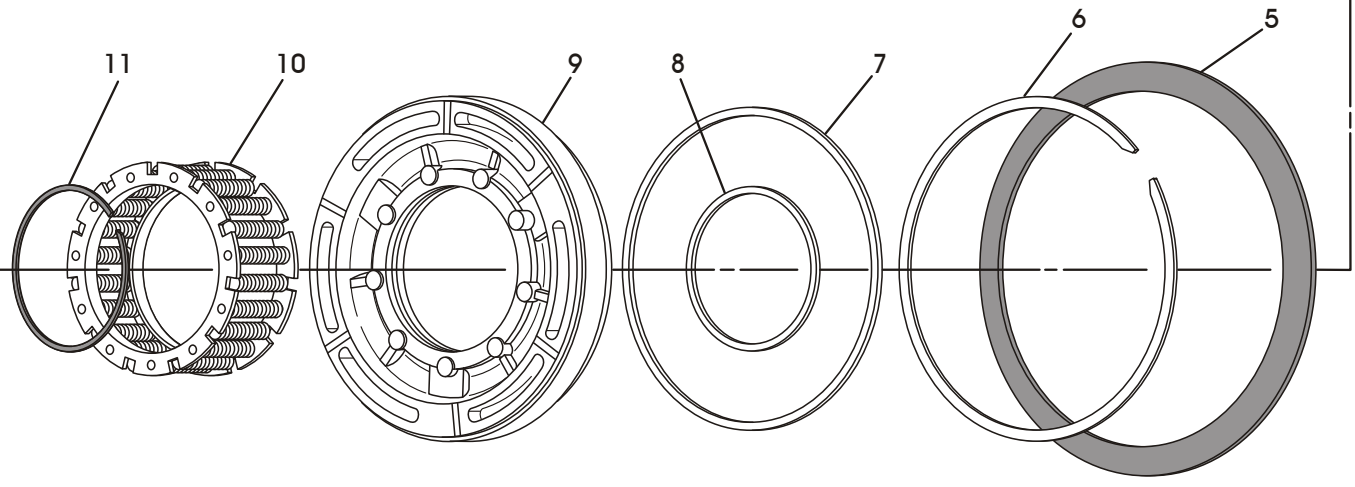
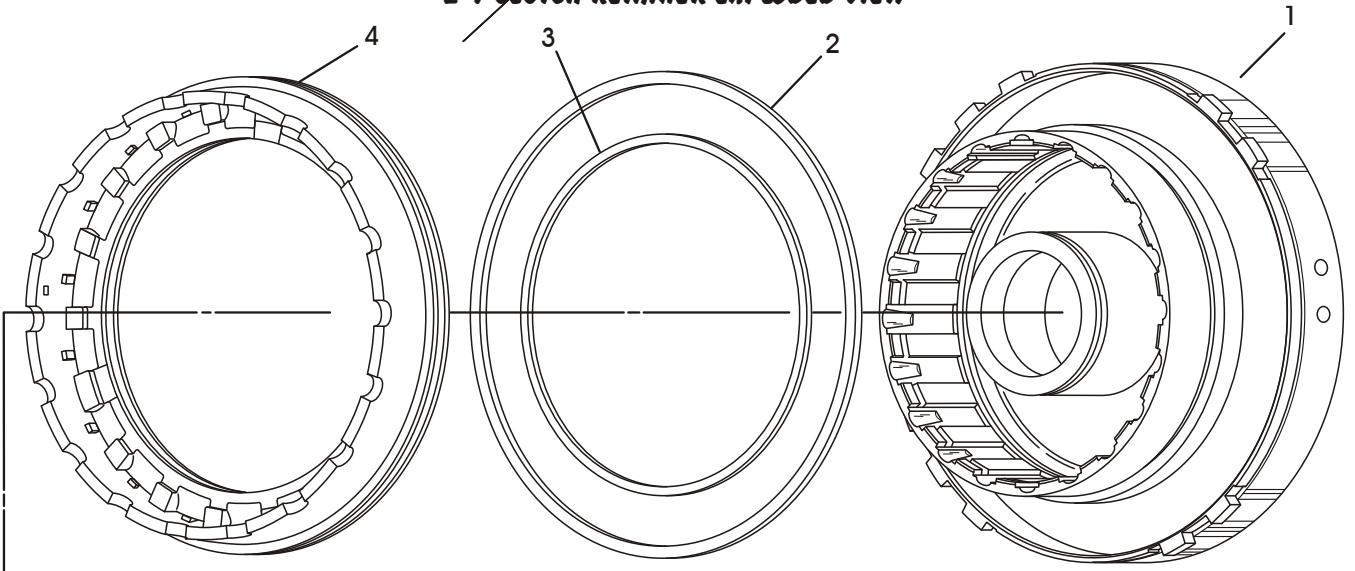

Copyright © 1999 ATSG

Figure 60

2-4 CLUTCH RETAINER EXPLODED VIEW

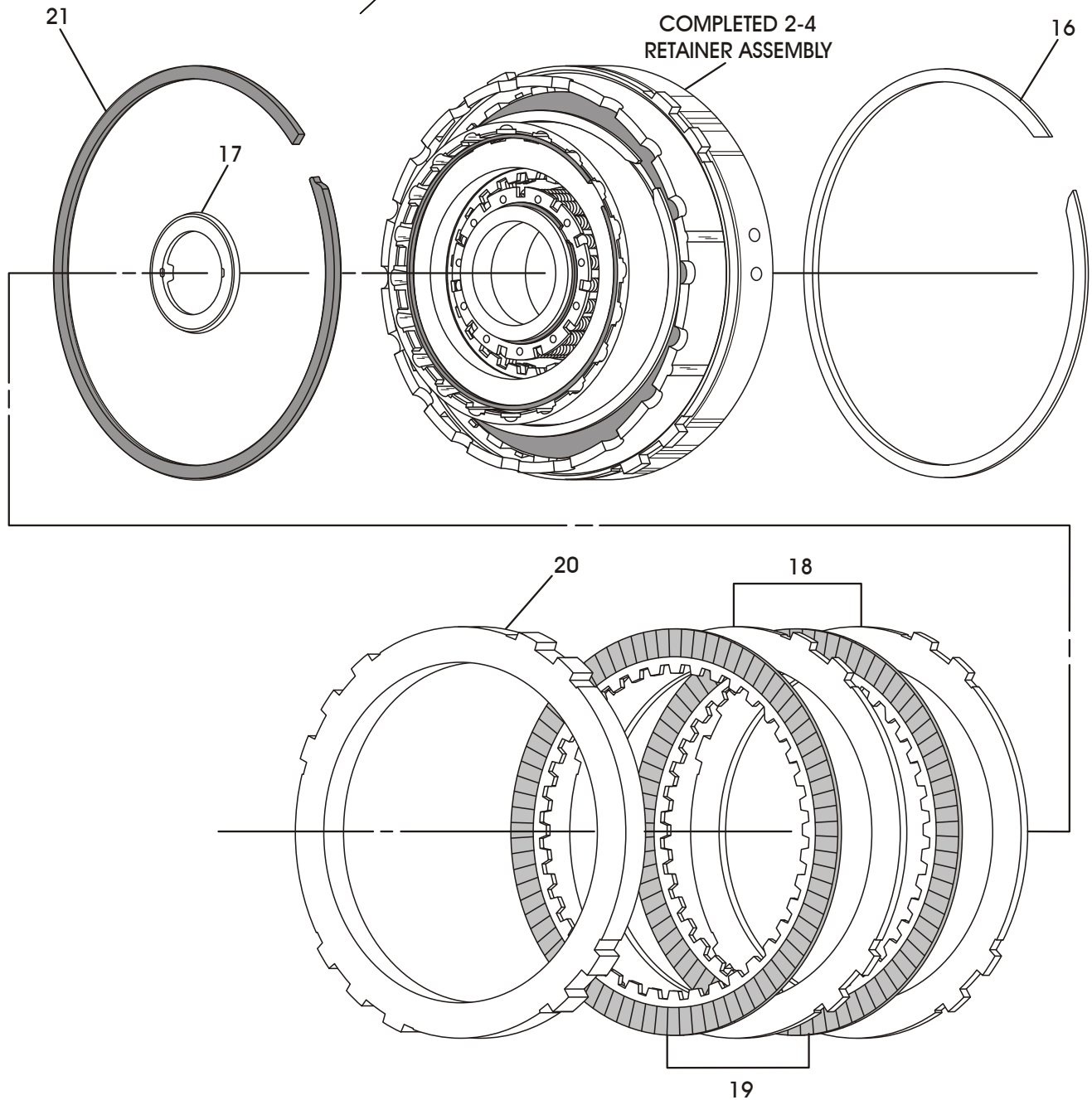

1. 2-4 CLUTCH RETAINER ASSEMBLY.
2. 2ND CLUTCH PISTON OUTER "D" RING SEAL.
3. 2ND CLUTCH PISTON INNER "D" RING SEAL.
4. 2ND CLUTCH PISTON.
5. 2ND CLUTCH BELLVILLE PLATE.
6. 2ND CLUTCH BELLVILLE PLATE RETAINING SNAP RING.
7. 4TH CLUTCH PISTON OUTER "D" RING SEAL (GOES IN SUPPORT).
8. 4TH CLUTCH PISTON INNER "D" RING SEAL.
9. 4TH CLUTCH PISTON.
10. 4TH CLUTCH PISTON RETURN SPRING ASSEMBLY.
11. 4TH CLUTCH PISTON RETURN SPRING RETAINING SNAP RING.

12. 4TH CLUTCH STEEL PLATES .098" THICK (3 REQUIRED).
13. 4TH CLUTCH FRICTION PLATES .090" THICK (3 REQUIRED).
14. 4TH CLUTCH PRESSURE PLATE .196" THICK.
15. 4TH CLUTCH PRESSURE PLATE "FLAT" SNAP RING (SELECTIVE).
16. 2-4 SUPPORT ASSEMBLY "TAPERED" SNAP RING (GOES IN CASE).
17. NUMBER 6 THRUST BEARING.
18. 2ND CLUTCH STEEL PLATES .127" THICK (2 REQUIRED).
19. 2ND CLUTCH FRICTION PLATES .092" THICK (2 REQUIRED).
20. 2ND CLUTCH PRESSURE PLATE (SELECTIVE)
21. 2-4 SUPPORT ASSEMBLY "FLAT" SNAP RING (GOES IN CASE).

Copyright © 1999 ATSG

Figure 61

2-4 CLUTCH RETAINER ASSEMBLY

1. Disassemble the 2-4 clutch retainer using the illustrations in Figures 60 and 61.
2. Clean and inspect all components and replace those components that show wear or damage.
3. Install new inner and outer seals on 2nd clutch piston, as shown in Figure 62, and lubricate with small amount of TransJel®.
4. Install the 2nd clutch piston in the 2-4 retainer as shown in Figure 62.
5. Install the 2nd clutch piston bellville plate on top of the 2nd clutch piston in retainer.
6. Position the 2nd clutch bellville plate snap ring on top of the bellville plate (See Figure 63).
7. Using a suitable shop press, compress bellville spring until the snap ring is engaged into the snap ring groove in the 2-4 retainer, and ensure that it is fully seated as shown in Figure 63.
8. Install new inner and outer seals on 4th clutch piston, as shown in Figure 65, and lubricate with small amount of TransJel®.
9. Install the 4th clutch piston in the 2-4 retainer as shown in Figure 65.
10. Install the 4th clutch piston return spring on top of the piston as shown in Figure 65.
11. Position the return spring retaining snap ring on top of the return spring (See Figure 65).

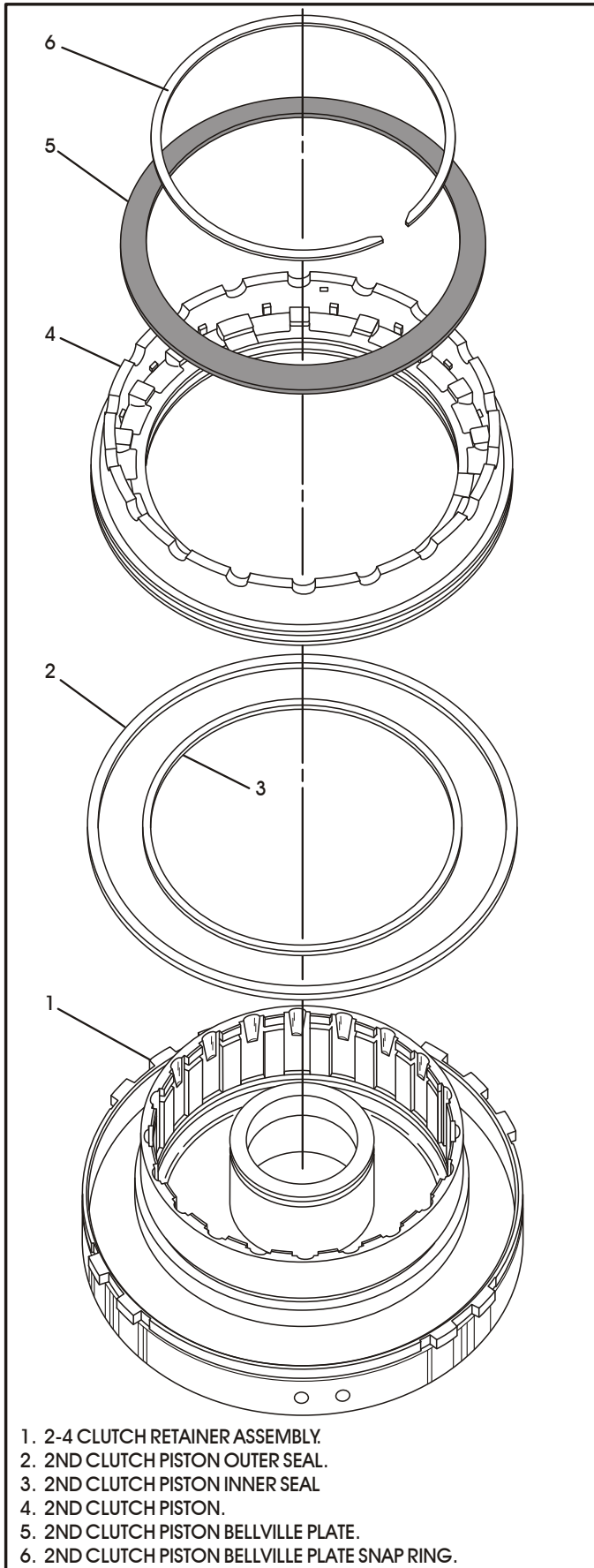

Figure 62

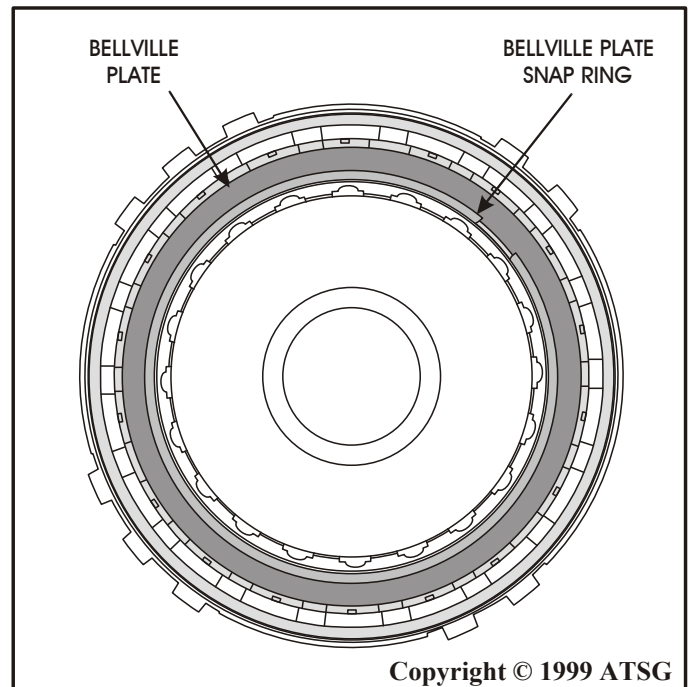

Figure 63

12. Using a suitable shop press, compress the 4th clutch return spring, and install the snap ring into the groove in the 2-4 retainer.
13. Ensure that the snap ring is fully seated, as shown in Figure 64.

Continued on Page 52.

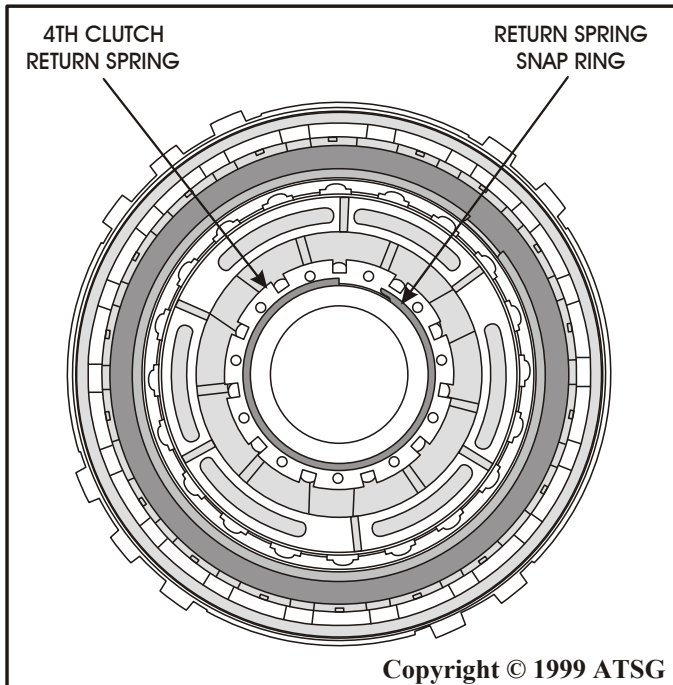

Figure 64

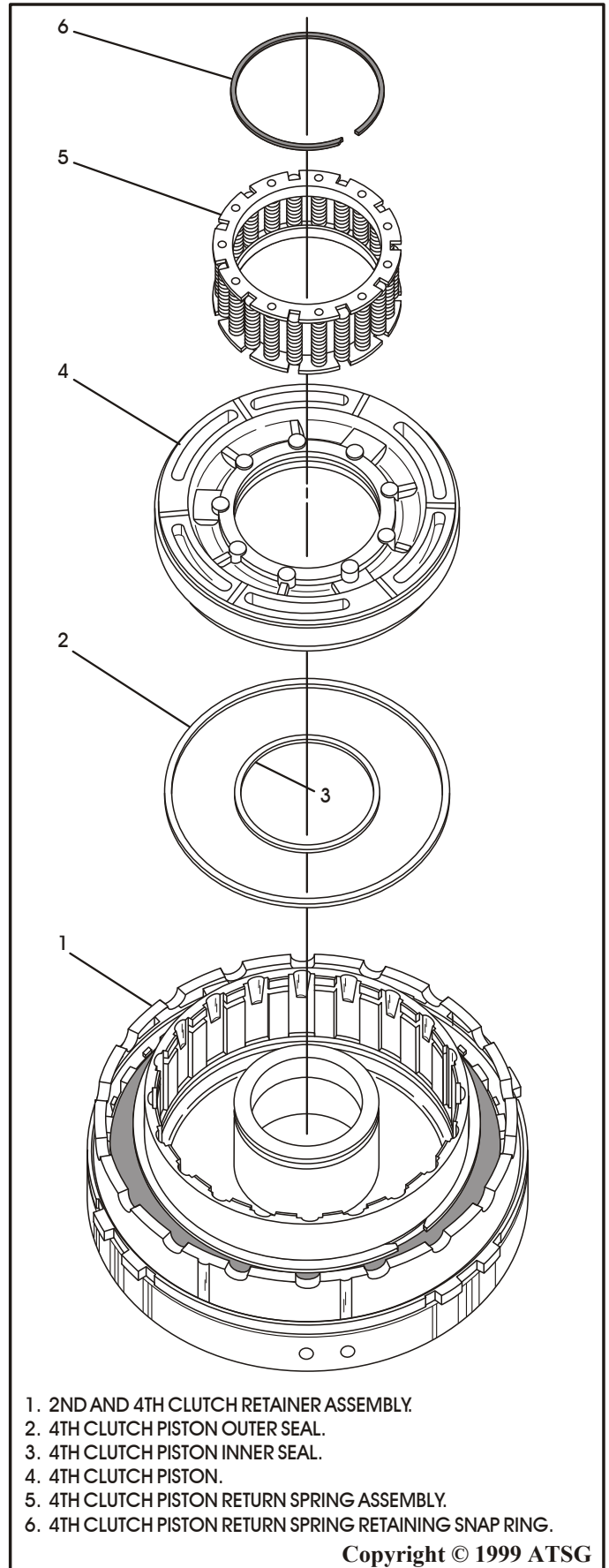

Figure 65

2-4 CLUTCH RETAINER ASSEMBLY (Cont'd)

14. Install the 4th clutch pack beginning with a steel plate and alternating with friction plate until you have installed three of each plate, as shown in Figure 66.
15. Install the 4th clutch backing plate, as shown in Figure 66. This plate is non-directional and will go in either way.
16. Install the 4th clutch backing plate *selective* snap ring as shown in Figure 66, and ensure that it is fully seated.
17. Measure the 4th clutch clearance. The correct clutch clearance is 0.81-1.35 mm (.032"-.053").
18. Change the snap ring as necessary and verify clutch clearance by re-measuring.
19. Set the completed 2-4 retainer assembly aside for final assembly (See Figure 67).

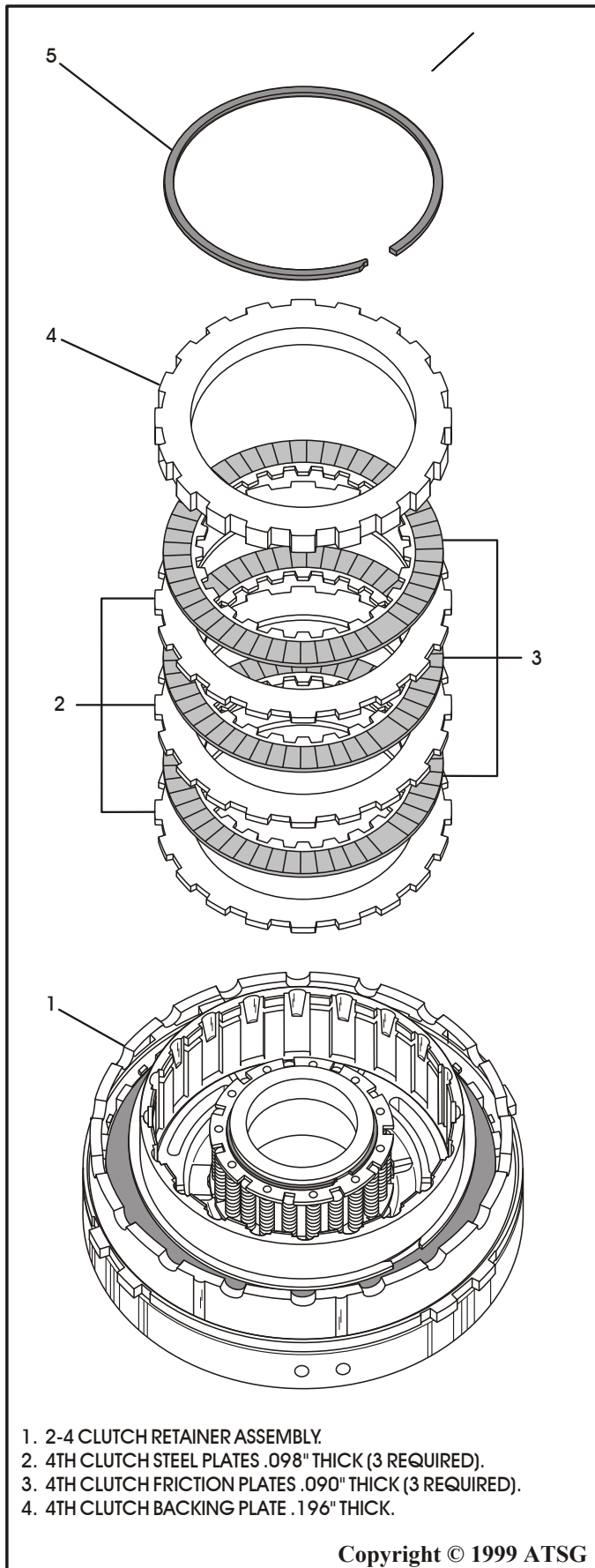

Figure 66

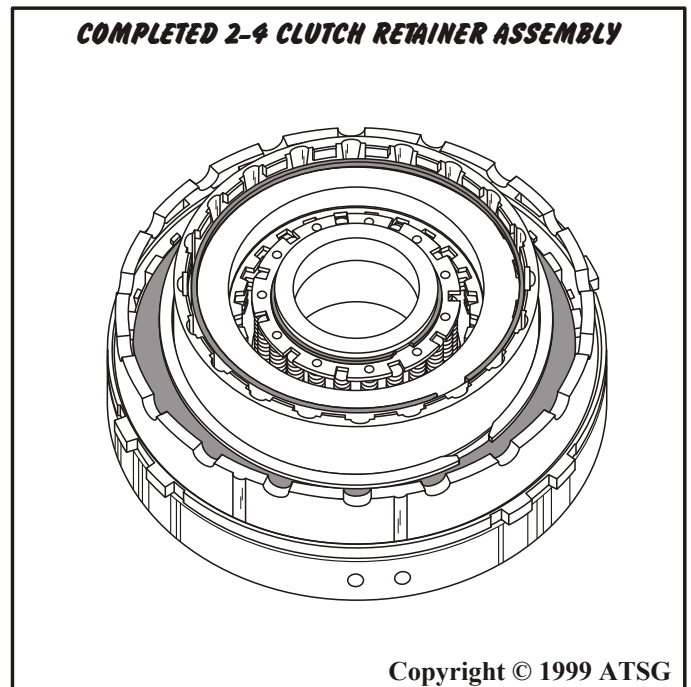

Figure 67

GEAR TRAIN COMPONENTS

1. Clean and inspect all geartrain components as shown in Figure 68. Replace any components that show evidence of wear or damage.
2. Set all inspected geartrain parts aside for the final assembly process.

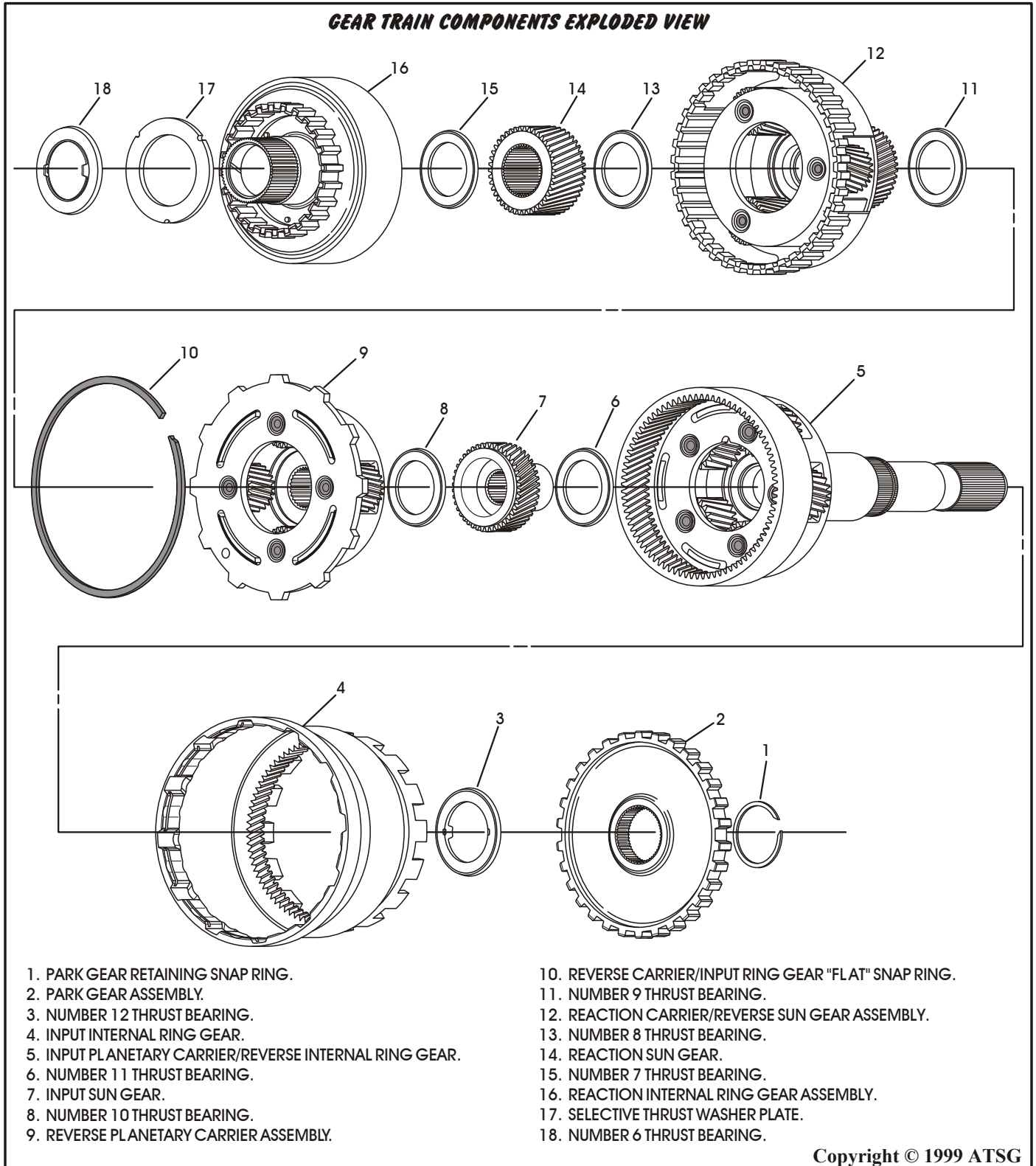
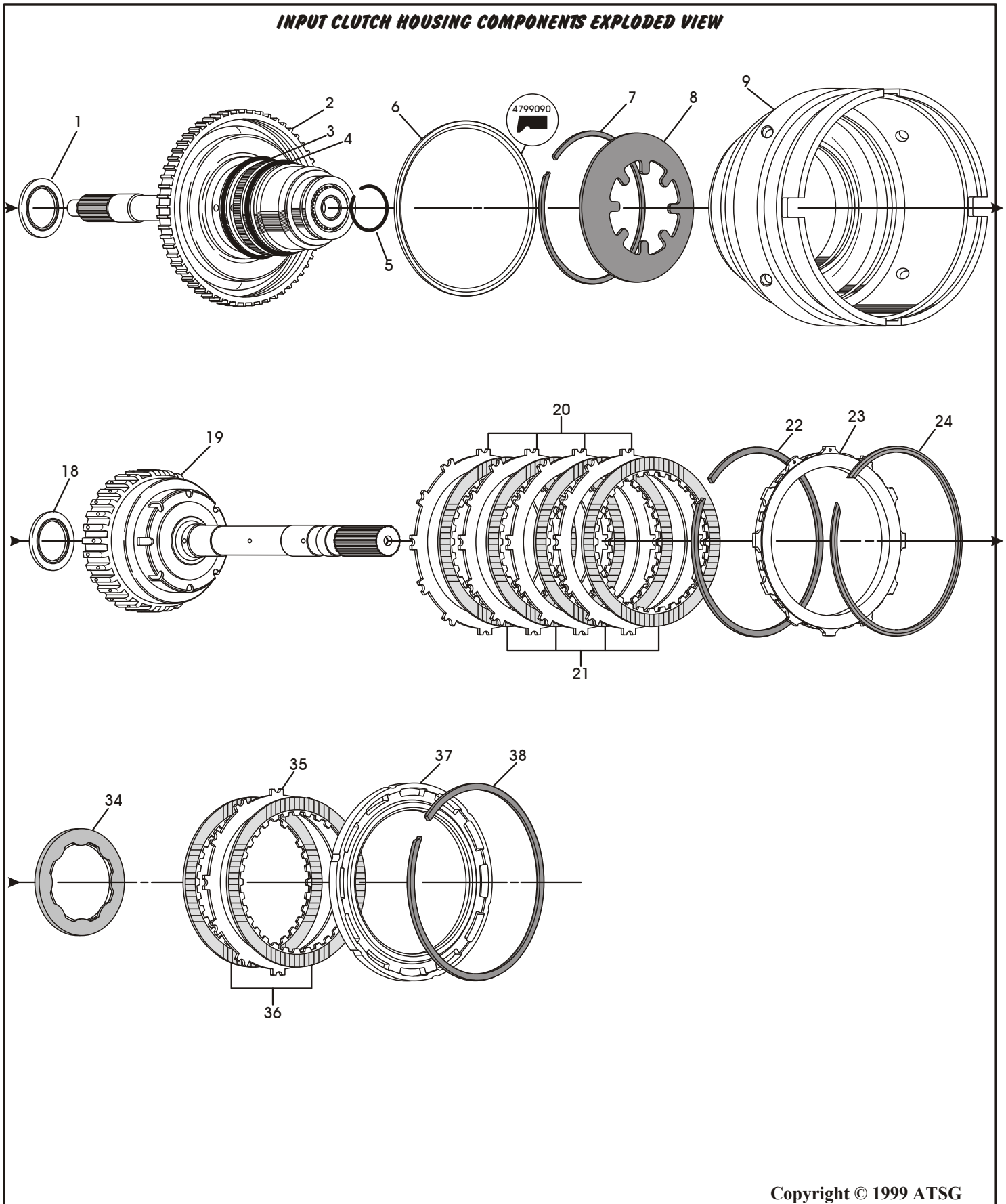

Figure 68



Copyright © 1999 ATSG

Figure 69

INPUT CLUTCH HOUSING COMPONENTS EXPLODED VIEW

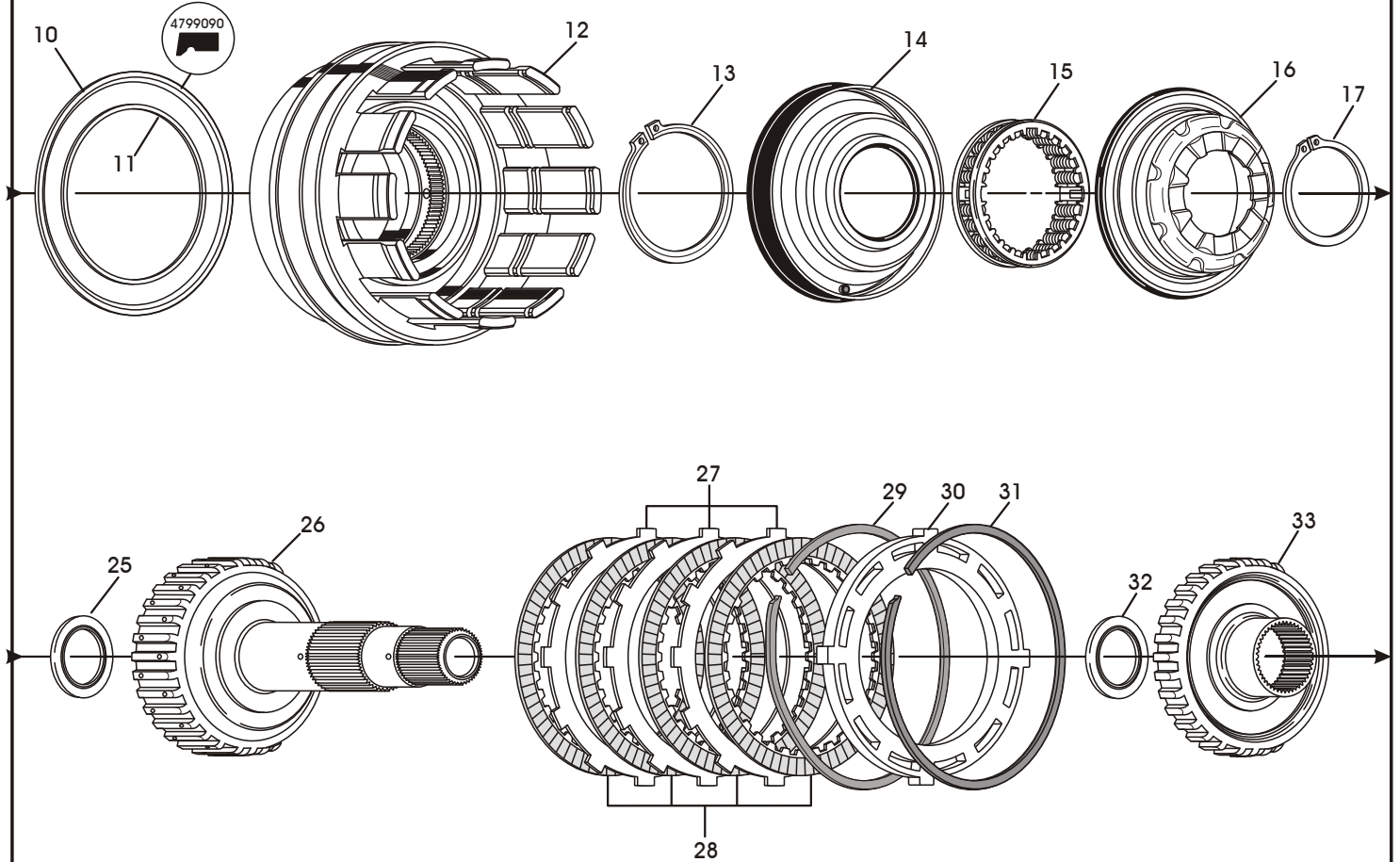

- | | |
|---|--|
| <ol style="list-style-type: none"> 1. NUMBER 1 THRUST BEARING. 2. INPUT CLUTCH HUB. 3. GREEN COLORED "O" RING. 4. RED COLORED "O" RING. 5. INPUT SHAFT RETAINING CIR-CLIP. 6. REVERSE OUTER LIP SEAL (INSIDE LIP). 7. OVERDRIVE/REVERSE PISTON BELLVILLE SNAP RING. 8. OVERDRIVE/REVERSE PISTON BELLVILLE PLATE. 9. OVERDRIVE/REVERSE PISTON ASSEMBLY. 10. OVERDRIVE OUTER LIP SEAL (INSIDE LIP). 11. OVERDRIVE/REVERSE INNER "O" RING. 12. INPUT CLUTCH RETAINER. 13. "BEVELED" SNAP RING (INSIDE BEVEL). 14. UNDERDRIVE CLUTCH PISTON ASSEMBLY. 15. UNDERDRIVE CLUTCH RETURN SPRING ASSEMBLY. 16. SPRING RETAINER AND BALANCE PISTON ASSEMBLY. 17. "FLAT" SNAP RING. 18. NUMBER 2 THRUST BEARING. | <ol style="list-style-type: none"> 20. UNDERDRIVE CLUTCH STEEL PLATES .067" THICK (4 REQUIRED). 21. UNDERDRIVE CLUTCH LINED PLATES .078" THICK (4 REQUIRED). 22. UNDERDRIVE/OVERDRIVE REACTION PLATE "FLAT" SNAP RING. 23. UNDERDRIVE/OVERDRIVE REACTION PLATE. 24. UNDERDRIVE/OD REACTION PLATE "TAPERED" SNAP RING. 25. NUMBER 3 THRUST BEARING. 26. OVERDRIVE CLUTCH HUB AND SHAFT ASSEMBLY. 27. OVERDRIVE CLUTCH STEEL PLATES .086" THICK (3 REQUIRED). 28. OVERDRIVE CLUTCH LINED PLATES .090" THICK (4 REQUIRED). 29. OVERDRIVE/REVERSE REACTION PLATE "WAVE" SNAP RING. 30. OVERDRIVE/REVERSE REACTION PLATE. 31. OVERDRIVE/REVERSE REACTION PLATE "FLAT" SNAP RING. 32. NUMBER 4 THRUST BEARING. 33. REVERSE CLUTCH HUB ASSEMBLY. 34. NUMBER 5 "SELECTIVE" THRUST BEARING ASSEMBLY. 35. REVERSE CLUTCH STEEL PLATE .067" THICK (1 REQUIRED). 36. REVERSE CLUTCH LINED PLATES .080" THICK (2 REQUIRED). 37. REVERSE CLUTCH BACKING PLATE. 38. REVERSE CLUTCH BACKING PLATE "FLAT" SNAP RING. |
|---|--|

Copyright © 1999 ATSG

Figure 70

INPUT CLUTCH HOUSING SNAP RING IDENTIFICATION CHART

	<i>Thickness</i>	<i>I.D. to O.D.</i>
<i>Snap Ring No. 1</i>	<i>Flat .060"</i>	<i>.187"</i>
<i>Snap Ring No. 2</i>	<i>Tapered .091"</i>	<i>Varies</i>
<i>Snap Ring No. 3</i>	<i>Flat .078"</i>	<i>Varies</i>
<i>Snap Ring No. 4</i>	<i>Flat .060"</i>	<i>.189"</i>
<i>Snap Ring No. 5</i>	<i>Tapered .095"</i>	<i>.139"</i>
<i>Snap Ring No. 6</i>	<i>Waved .060"</i>	<i>.155"</i>
<i>Snap Ring No. 7</i>	<i>Flat .060"</i>	<i>.186"</i>
<i>Snap Ring No. 8</i>	<i>Flat .072"</i>	<i>.187"</i>

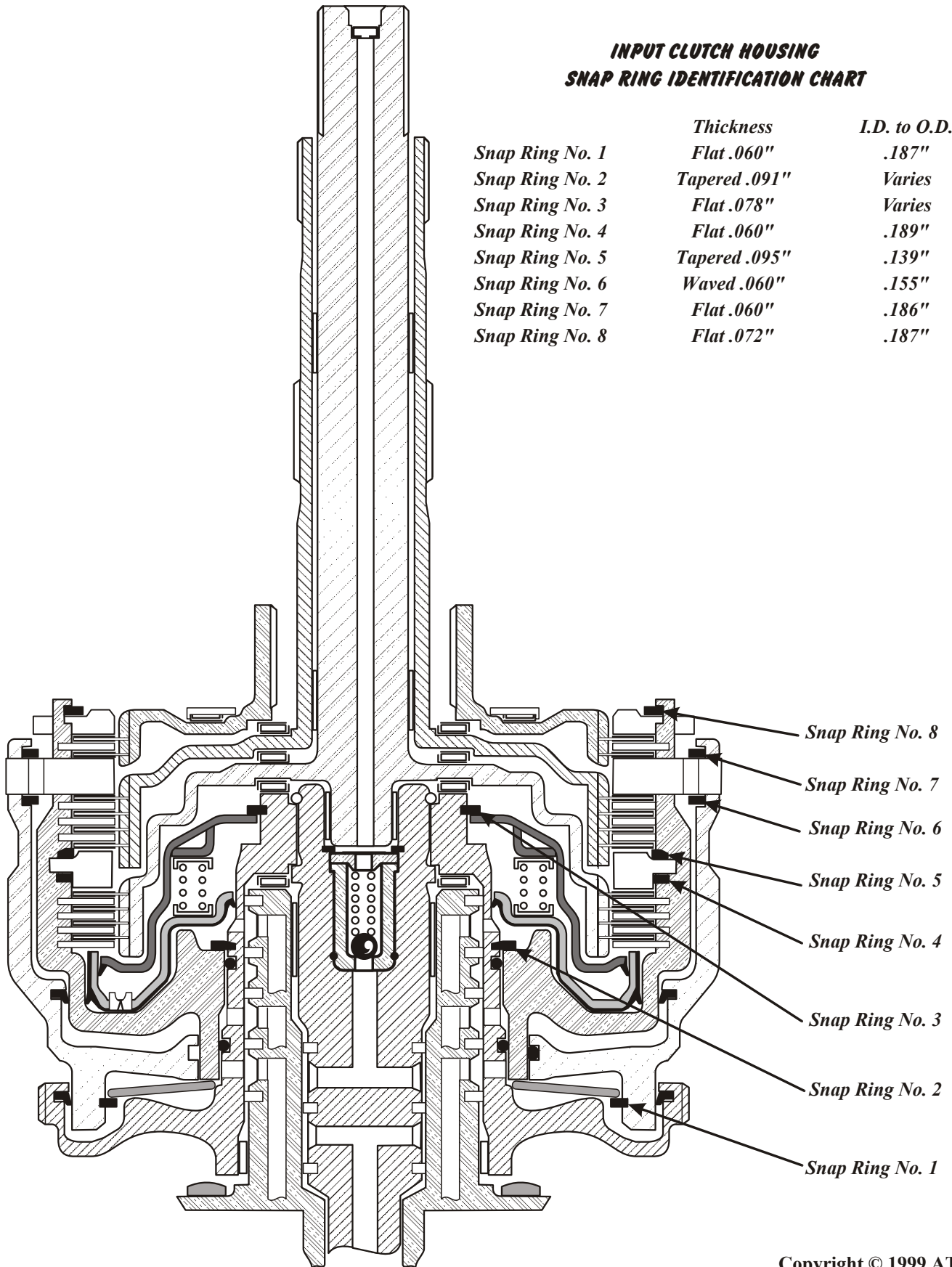

Copyright © 1999 ATSG

Figure 71

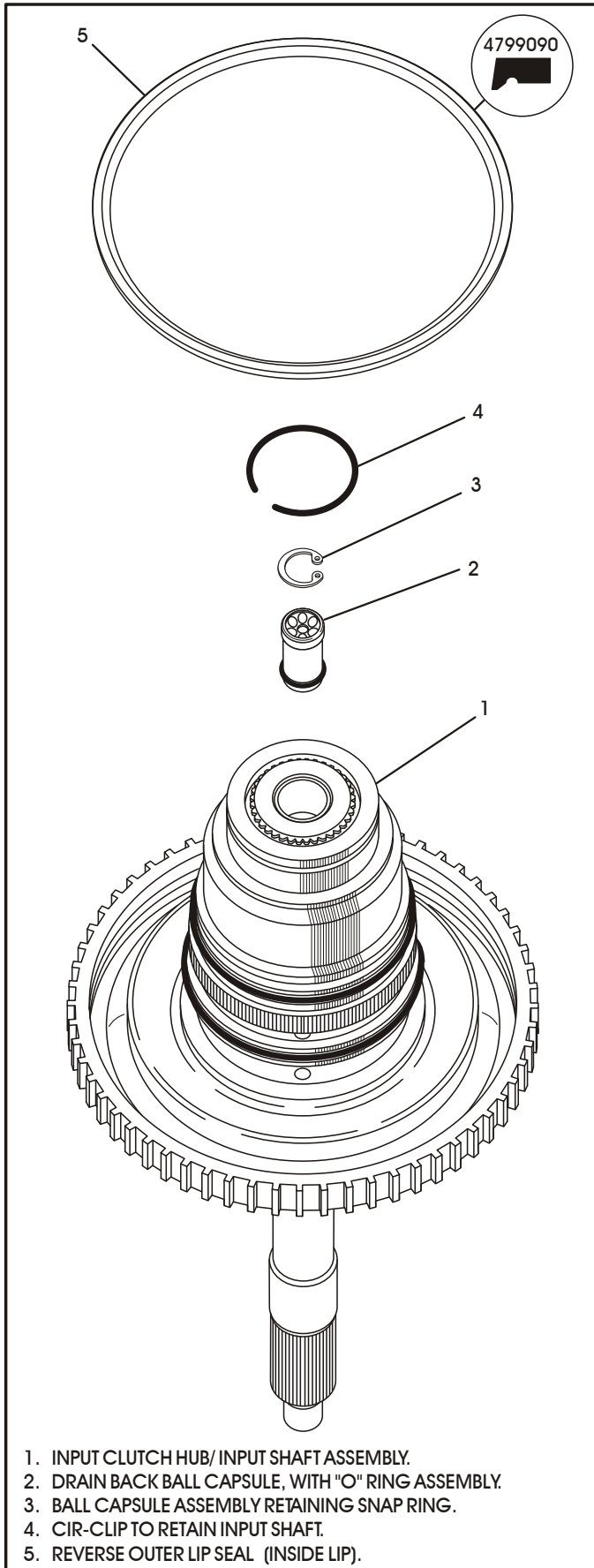

Figure 72

INPUT CLUTCH HOUSING ASSEMBLY

1. Disassemble the input clutch housing using the illustrations in Figures 69 and 70 as a guide.
2. Clean and inspect all components. Replace any parts that show evidence of wear or damage.
3. Remove the small "eyelet" snap ring from the input shaft as shown in Figure 72.
4. Remove the drain back ball capsule assembly from the input shaft using a pick tool. Remove and discard the "O" ring (See Figure 72).
5. Install a new "O" ring on the ball capsule and lubricate with small amount of TransJel®.
6. Install the drain back ball capsule back into the input shaft in the direction shown in Figure 72.
7. Install the "eyelet" snap ring and ensure that it is fully seated (See Figure 72).
8. Install new lip seal into the groove in the input clutch hub with the lip facing down as shown in Figure 72 and lubricate with a small amount of TransJel®.
9. The "O" rings on the input clutch hub are color coded. Install Green and Red colored "O" rings in the positions shown in Figure 73, and lube with a small amount of TransJel®.

Continued on Page 58.

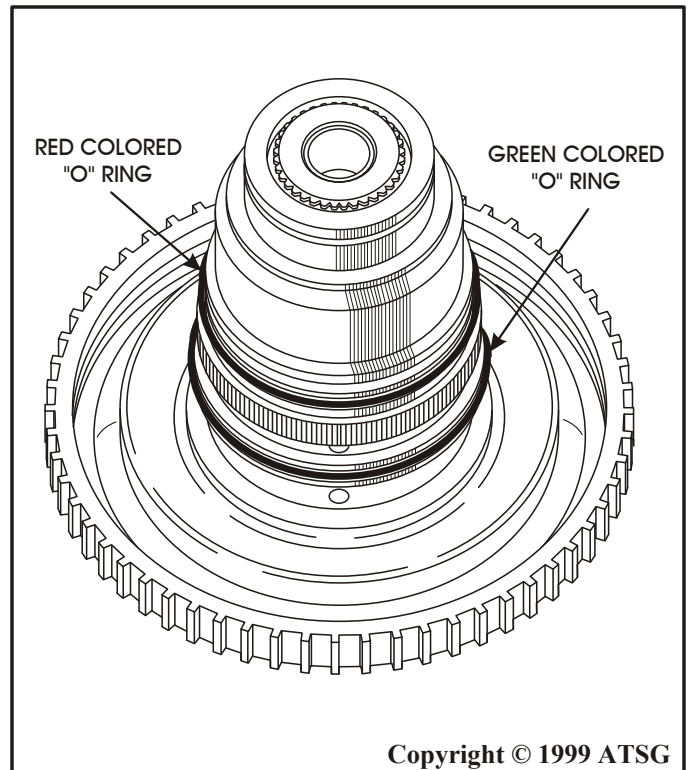

Figure 73

Copyright © 1999 ATSG

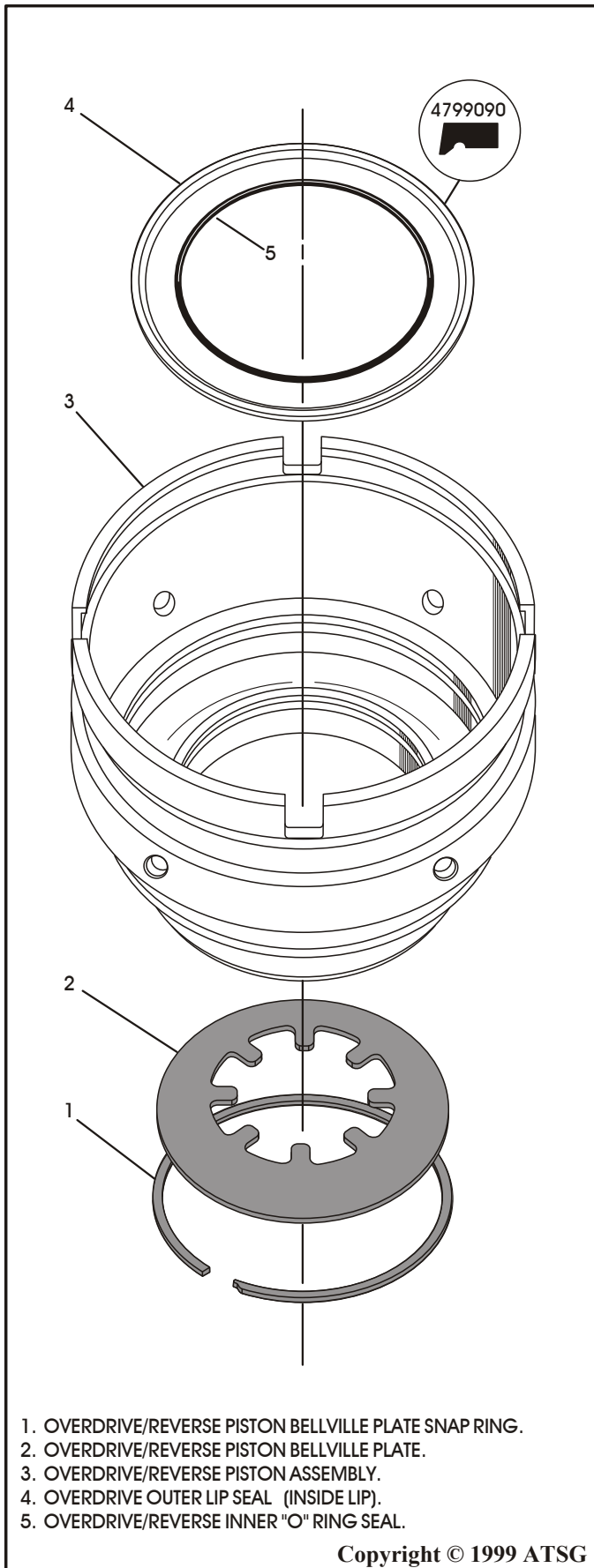

Figure 74

INPUT CLUTCH HOUSING ASSEMBLY (Cont'd)

10. Install the overdrive/reverse bellville plate and the retaining snap ring as shown in Figure 74, if they were removed.
11. Install the overdrive outer lip seal into groove inside the overdrive/reverse piston, with the lip facing down, as shown in Figure 74.
12. Install the overdrive/reverse inner "O" ring seal into the groove in the overdrive/reverse piston as shown in Figure 74.
13. Lubricate both seals with small amount of TransJel®.
14. Install the input clutch retainer into overdrive/reverse piston by rotating into position, as shown in Figure 75.
15. Install input clutch retainer and OD/Reverse piston assembly onto the input clutch hub, as shown in Figure 76.
16. Install the input clutch retainer *tapered* snap ring, with the *tapered side facing up*, into the groove in the input clutch hub as shown in Figure 76.

Special Note: We have provided you with a snap ring identification chart to identify the snap rings, and identify their locations, in Figure 71 on Page 56. This chart will identify all snap rings in the input housing.

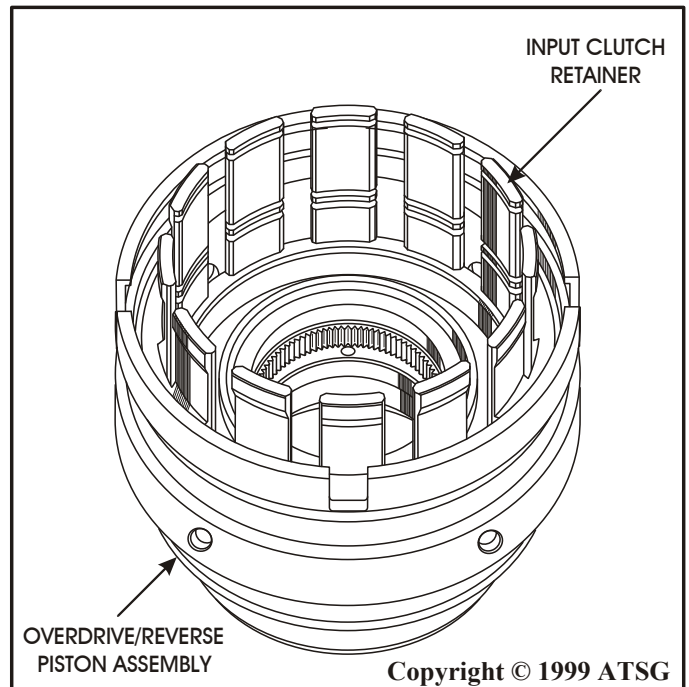

Figure 75

17. Install the input clutch molded rubber piston in input clutch retainer as shown in Figure 77.
18. Install the input clutch piston return spring on top of the input clutch piston (See Figure 77).
19. Install the spring retainer/balance piston, as shown in Figure 77. The balance piston also has a molded seal.
20. Using a suitable shop press, compress return spring assembly and install the flat snap ring into the groove. Refer to Figure 77 and snap ring chart in Figure 71.

Continued on Page 60.

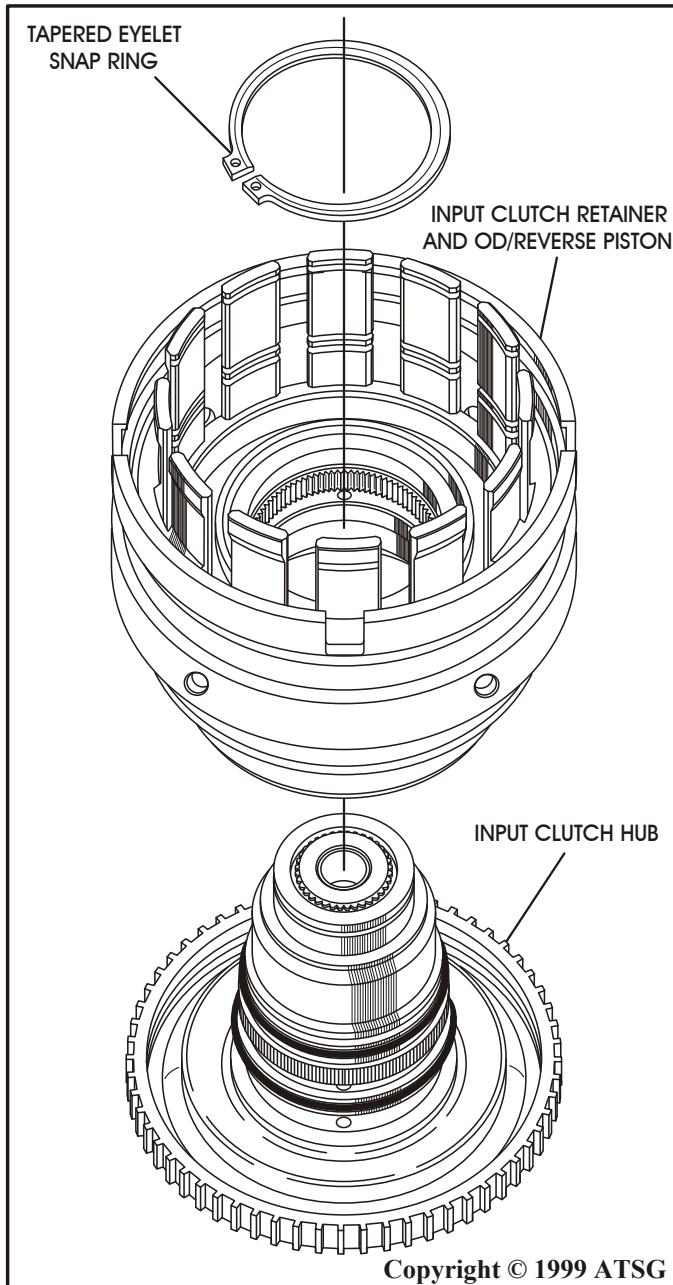

Figure 76

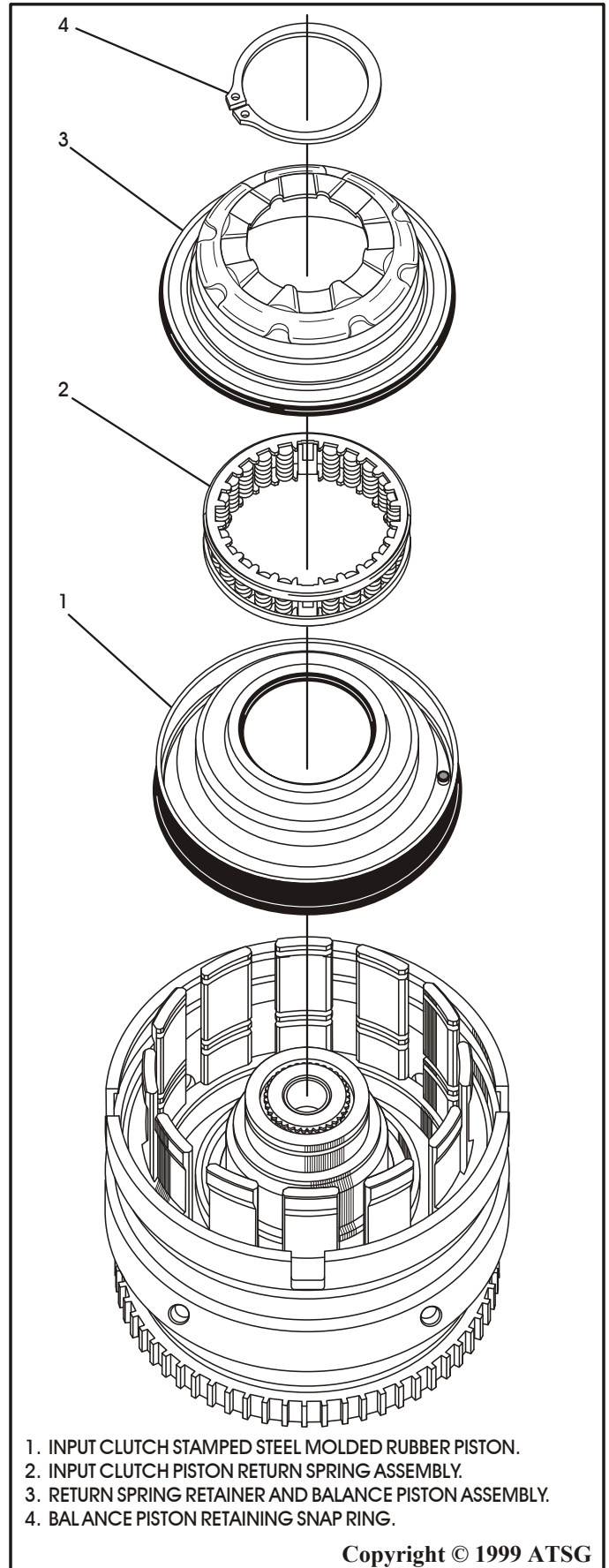

Figure 77

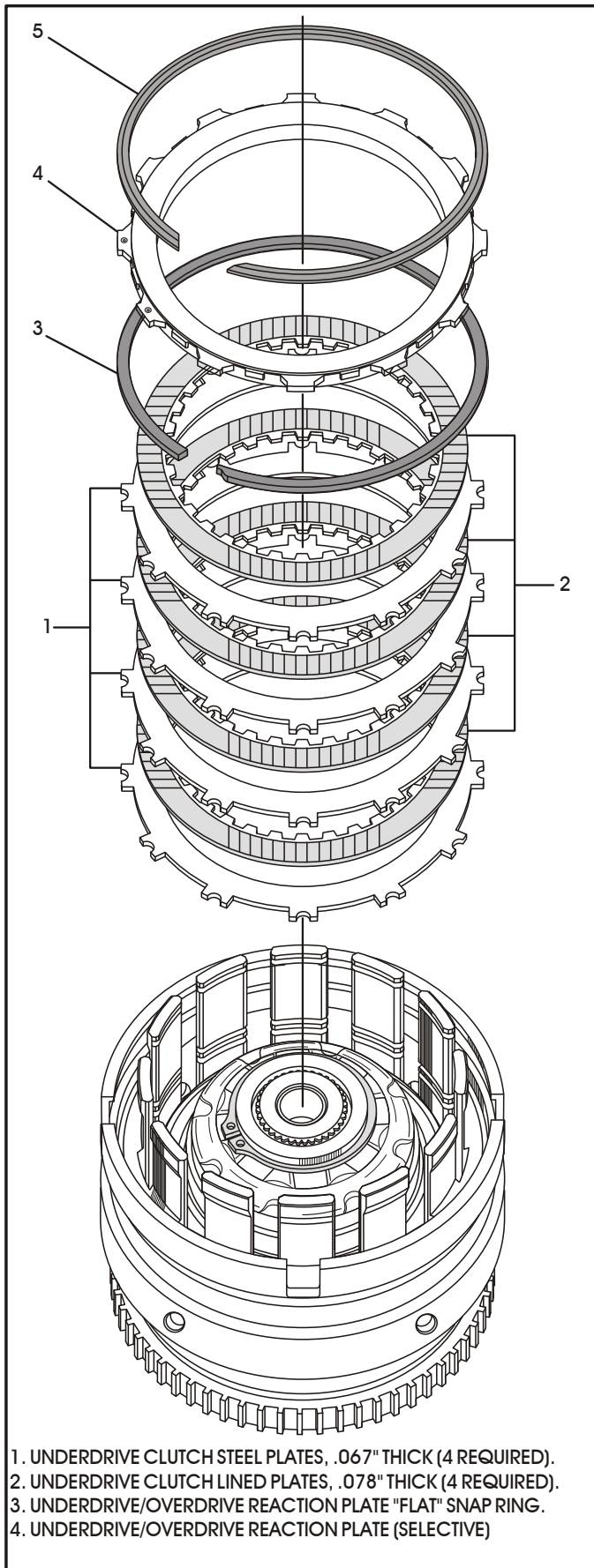

Figure 78

INPUT CLUTCH HOUSING ASSEMBLY (Cont'd)

21. Install the underdrive clutch pack starting with a steel plate and alternating with a lined plate until you have installed four of each, as shown in Figure 78. Note that the underdrive steel plates have a half-moon cut in each of the tabs.
22. Install the underdrive/overdrive reaction plate lower **flat** snap ring into the housing in the lower groove (See Figure 78).

Special Note: We have provided you with a snap ring identification chart to identify the snap rings, and identify their locations, in Figure 71 on Page 56. This chart will identify all snap rings in the input housing.

23. Install the underdrive/overdrive reaction plate into the input clutch retainer, with the big step facing down as shown in Figure 78. This plate is also selective to achieve proper underdrive clutch clearance.
24. Install the underdrive/overdrive reaction plate upper **tapered** snap ring into the housing with the tapered side facing up (See Figure 78).

Special Note: We have provided you with a snap ring identification chart to identify the snap rings, and identify their locations, in Figure 71 on Page 56. This chart will identify all snap rings in the input housing.

25. Mount a dial indicator to the assembly and zero the the indicator against the tooth of the clutch friction disc. Apply 20 psi of air pressure to the underdrive clutch and record the dial reading.
26. The correct underdrive clutch clearance should be 0.76-1.60 mm (.030"-.063").
27. Adjust as necessary by changing the reaction plate and re-measure to verify proper clearance.

28. Install the overdrive clutch pack starting with a lined plate and alternating with steel plates until you have installed 4 lined and 3 steel plates, as shown in Figure 79. Note that the overdrive plates do not have the half-moon cut on tabs.
29. Install the overdrive/reverse reaction plate **wave** snap ring into the wide groove in the overdrive/reverse piston and push the snap ring to the bottom of the groove (See Figure 79).

Special Note: We have provided you with a snap ring identification chart to identify the snap rings, and identify their locations, in Figure 71 on Page 56. This chart will identify all snap rings in the input housing.

30. Install the overdrive/reverse reaction plate into the retainer as shown in Figure 79. The reaction plate is non-directional and can be installed in either direction.
31. Install the overdrive/reverse reaction plate **flat** snap ring on top of the reaction plate and into wide groove in overdrive/reverse piston, by pushing down on the reaction plate to pre-load the wave snap ring.

Special Note: We have provided you with a snap ring identification chart to identify the snap rings, and identify their locations, in Figure 71 on Page 56. This chart will identify all snap rings in the input housing.

32. Mount a dial indicator to the assembly and zero the indicator against the OD/reverse reaction plate. Apply 20 psi of air pressure to the overdrive clutch and record the indicator reading.
33. The correct overdrive clutch clearance should be 1.016-1.650 mm (.040"-.065").
34. There are no selectives for the overdrive clutch pack. **If the overdrive clutch clearance is not correct, you have something mis-assembled.**

Continued on Page 62.

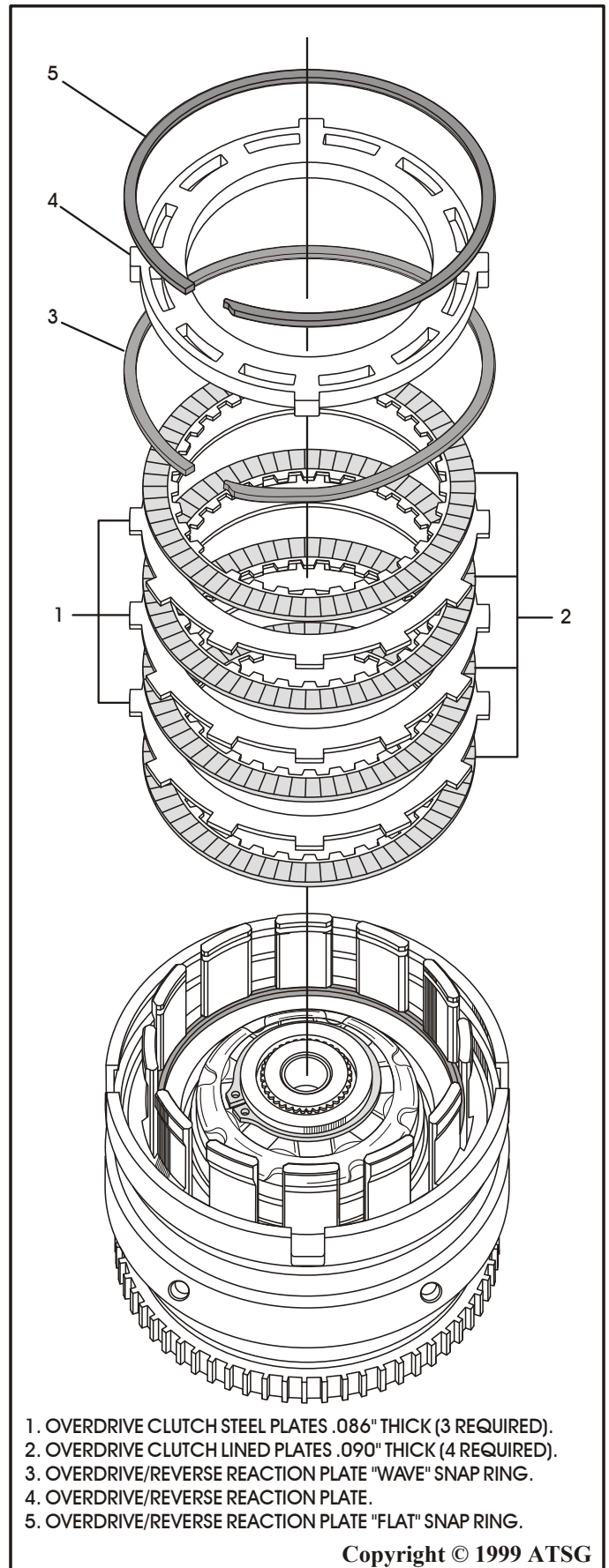

Figure 79

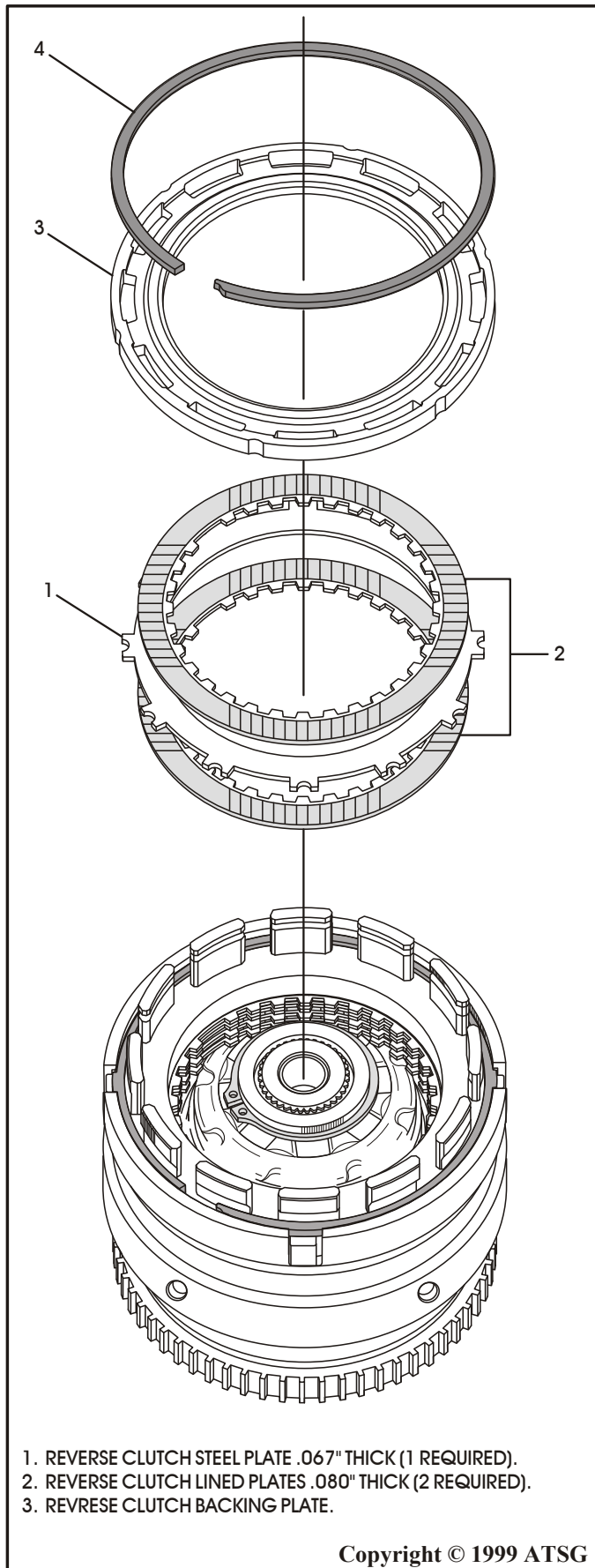

Figure 80

INPUT CLUTCH HOUSING ASSEMBLY (Cont'd)

35. Install the reverse clutch pack beginning with a lined plate and alternating with steel plate until you have installed two lined plates and 1 steel plate, as shown in Figure 80.
36. Install the reverse clutch backing plate with the flat side down, as shown in Figure 80.
37. Install reverse clutch backing plate *selective* snap ring as shown in Figure 80.

Special Note: We have provided you with a snap ring identification chart to identify the snap rings, and identify their locations, in Figure 71 on Page 56. This chart will identify all snap rings in the input housing.

38. Mount a dial indicator to the assembly and zero the the indicator against the tooth of the clutch friction disc. Apply 20 psi of air pressure to the reverse clutch and record the dial reading.
39. The correct reverse clutch clearance should be 0.81-1.24 mm (.032"-.049").
40. Adjust as necessary by changing backing plate selective snap ring and re-measure to verify the proper reverse clutch clearance.
41. Remove the reverse clutch pack from the input housing assembly to install the 3 clutch hubs and shafts.
42. Install the number 2 thrust bearing into the underdrive clutch hub and shaft, in direction shown in Figure 81, and retain with TransJel®.
43. Install the underdrive clutch hub and shaft into input housing, by turning until all underdrive clutches are engaged and it is fully seated.
44. Install the number 3 thrust bearing into the overdrive clutch hub and shaft, in the direction shown in Figure 82, and retain with TransJel®.
45. Install the overdrive clutch hub and shaft into input housing, by turning until all overdrive clutches are engaged and it is fully seated.

Continued on page 64.

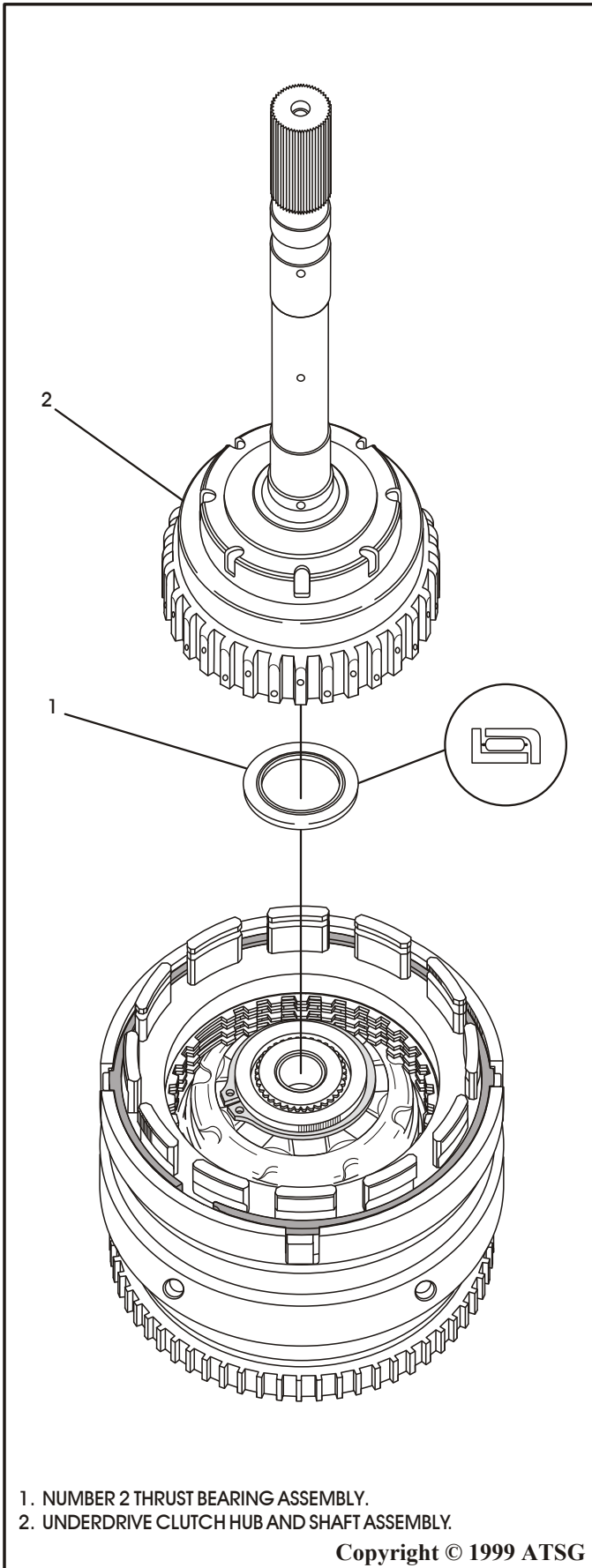

Figure 81

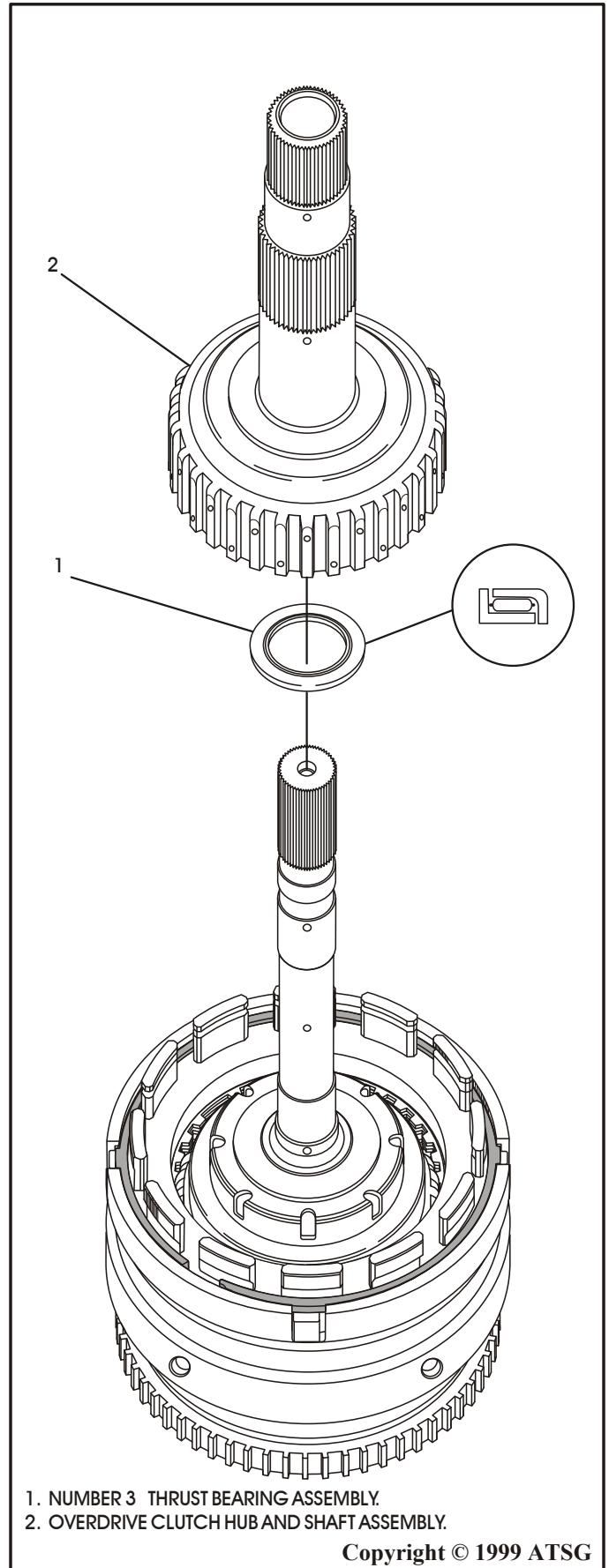

Figure 82

INPUT CLUTCH HOUSING ASSEMBLY (Cont'd)

46. Install the number 4 thrust bearing into reverse clutch hub, in the direction shown in Figure 83, and retain with small amount of TransJel®.
47. Install the reverse clutch hub assembly into the input housing over both shafts, as shown in Figure 83.
48. Re-install the reverse clutch pack completely as shown in Figure 80.
49. Install the number 5 selective thrust bearing on the back side of reverse clutch hub as shown in Figure 84 and retain with TransJel®.
50. Set the completed input housing assembly aside for the final assembly process.

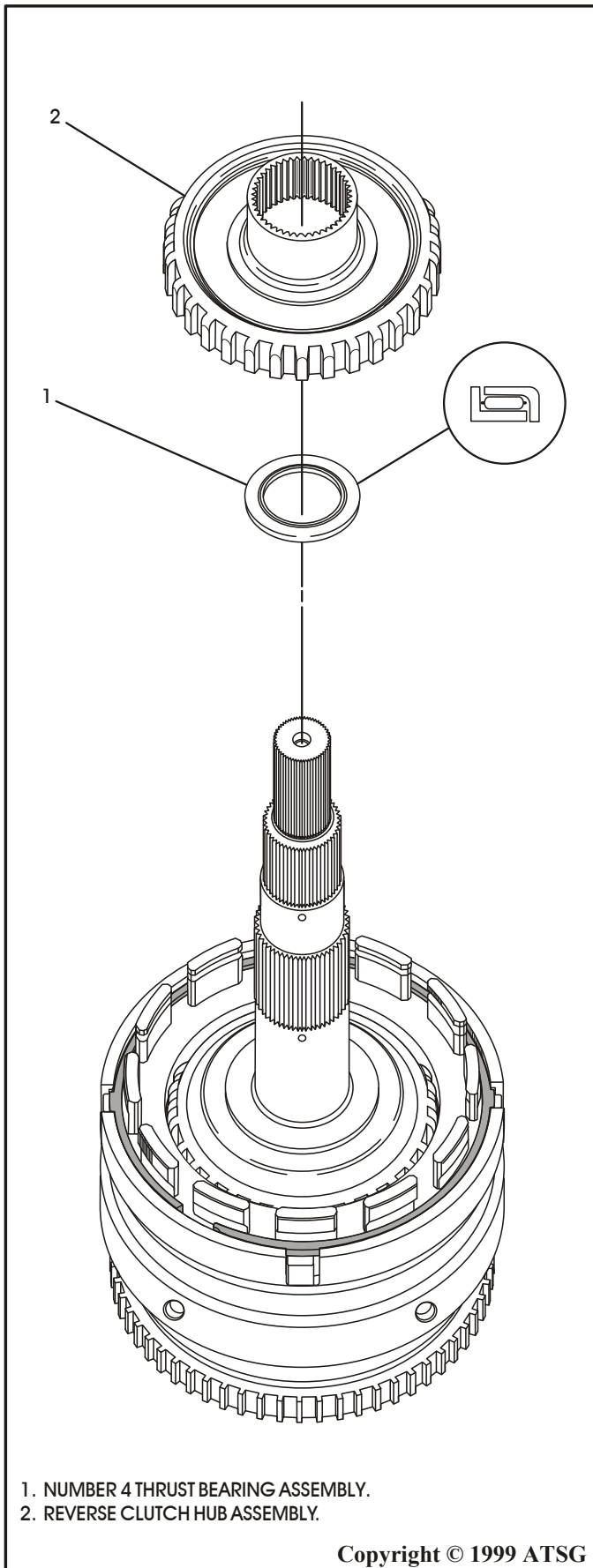

Figure 83

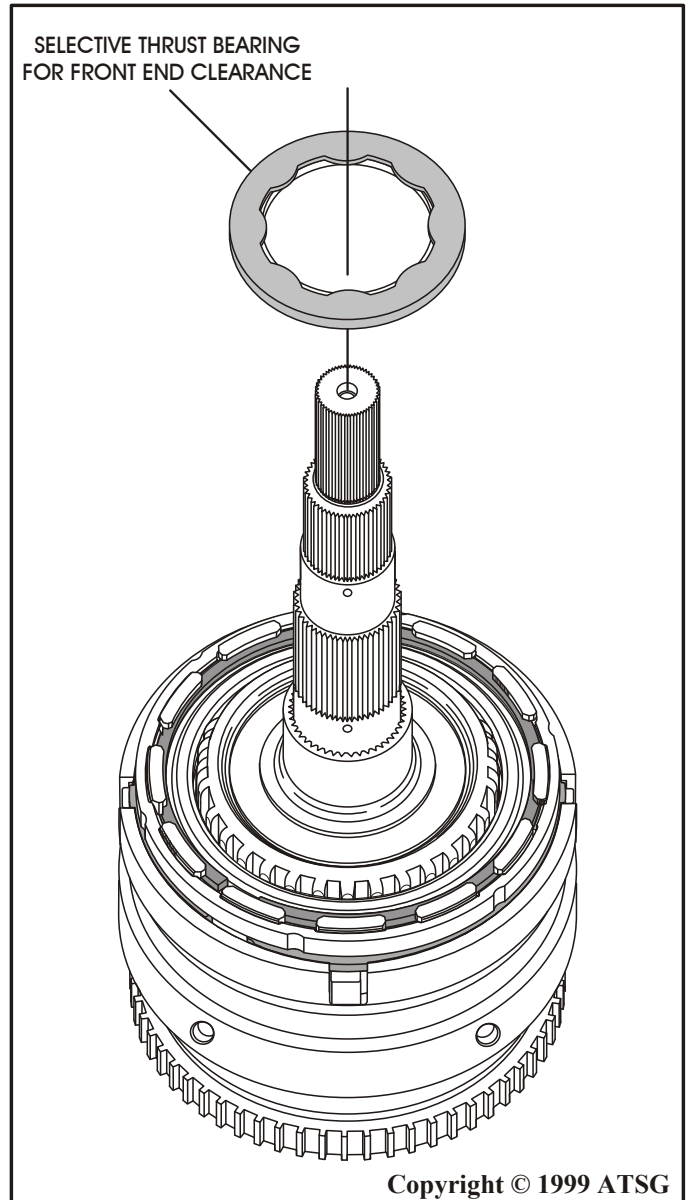
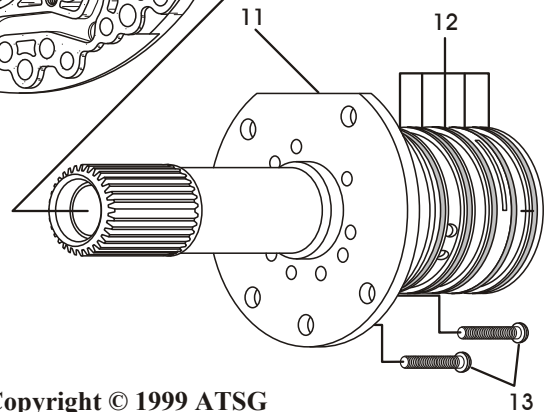
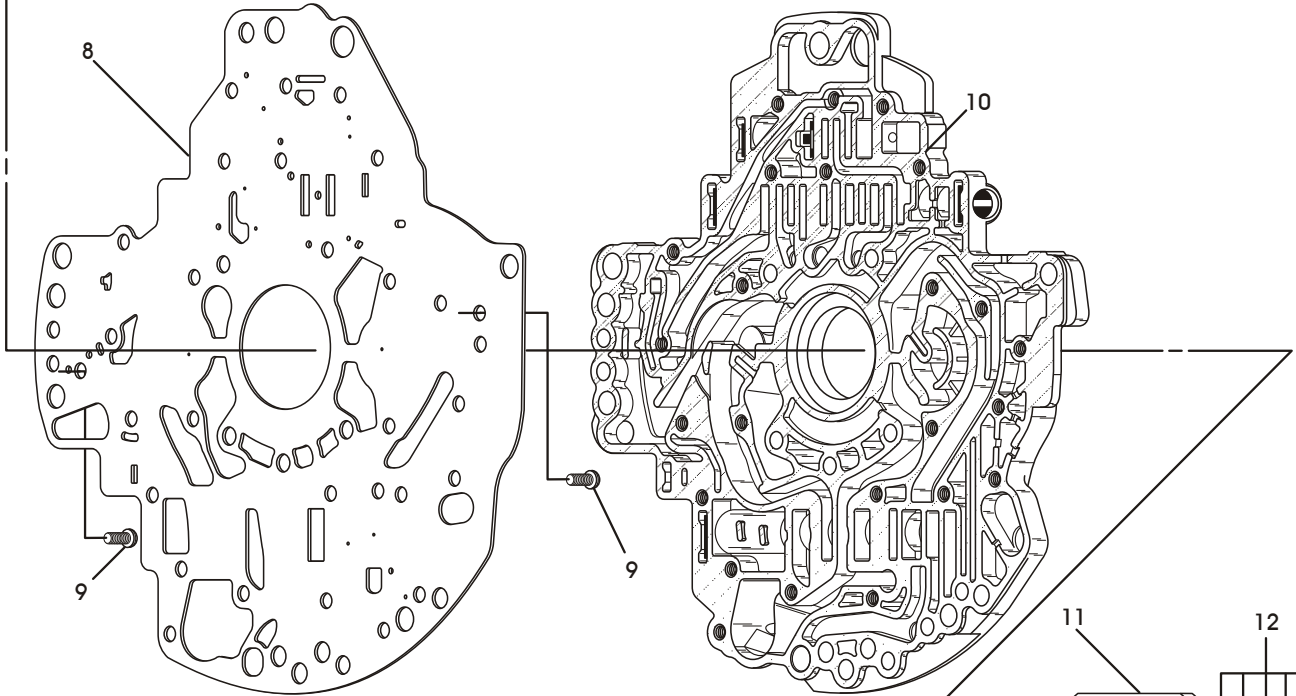
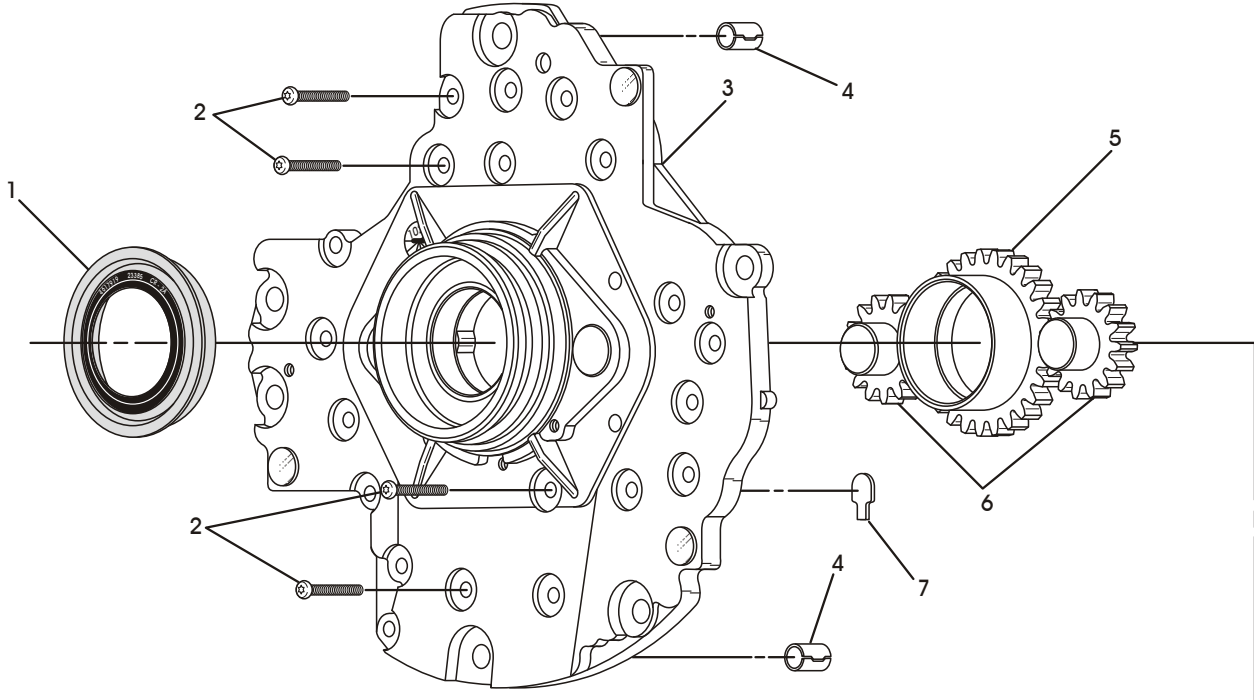

Figure 84

OIL PUMP ASSEMBLY EXPLODED VIEW



1. FRONT OIL PUMP CONVERTER SEAL.
2. PUMP BODY TO PUMP COVER RETAINING BOLTS (24 REQUIRED).
3. OIL PUMP BODY ASSEMBLY.
4. PUMP BODY TO PUMP COVER "HOLLOW" DOWELS (2 REQUIRED).
5. OIL PUMP DRIVE GEAR.
6. OIL PUMP DRIVEN GEARS.
7. OIL PUMP SHUTTLE VALVE.
8. OIL PUMP SPACER PLATE.
9. OIL PUMP SPACER PLATE RETAINING BOLTS (2 REQUIRED).
10. OIL PUMP COVER ASSEMBLY.
11. PUMP STATOR ASSEMBLY.
12. PUMP STATOR SEALING RINGS (5 REQUIRED).

Copyright © 1999 ATSG

13

Figure 85

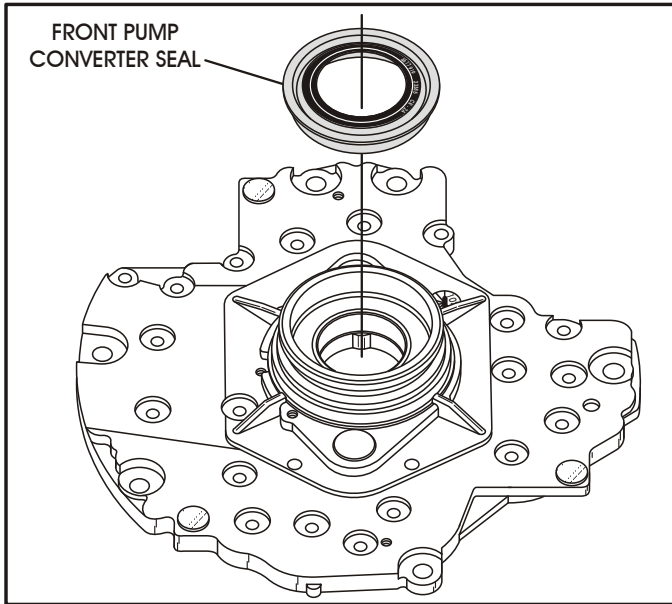

Figure 86

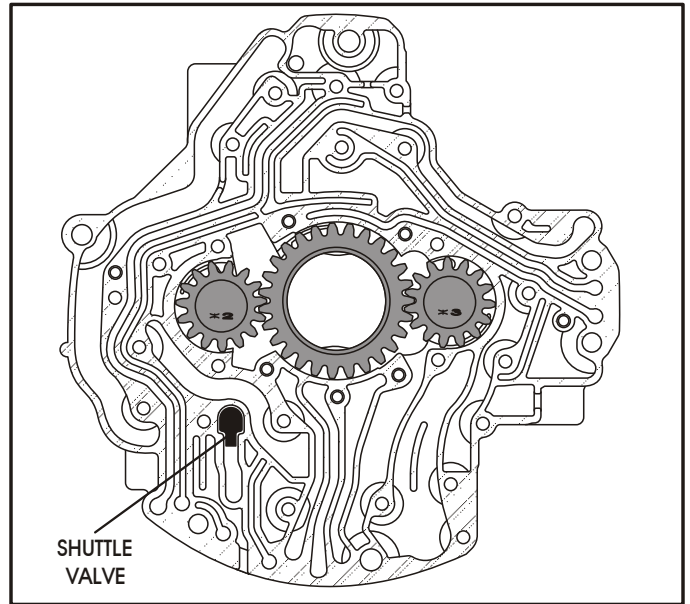

Figure 87

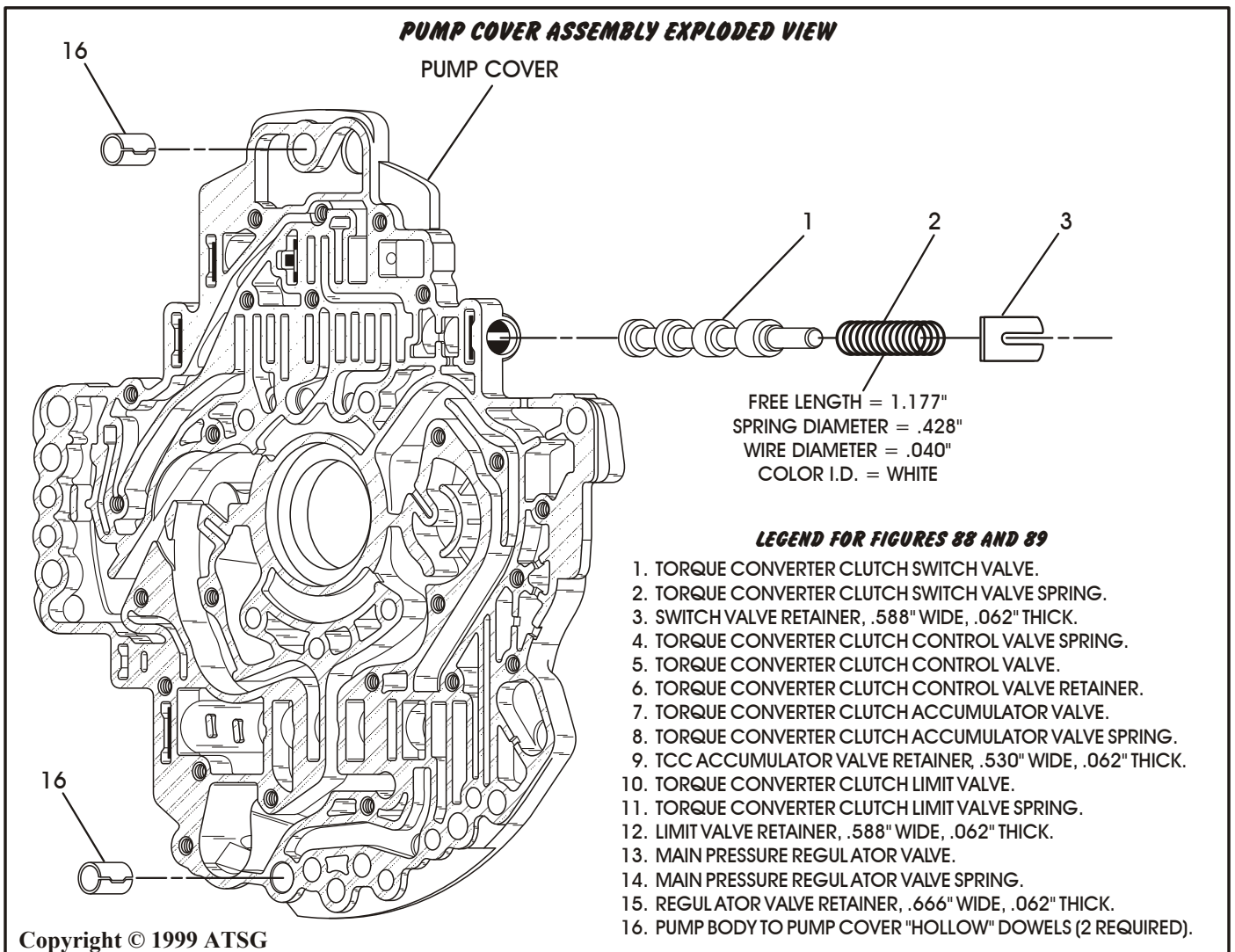

Figure 88

OIL PUMP AND COVER ASSEMBLY

1. Disassemble the complete oil pump assembly using Figure 85 as a guide.
2. Remove all valves and springs from the pump cover using Figures 88 and 89 as a guide.
3. Clean and inspect all components. Replace any parts that show wear or damage.
4. Notice that there is not a pump body bushing, but there are bushings in the stator to inspect.
5. Install a new converter seal into the pump body using the proper driver as shown in Figure 86.
6. Dip all 3 of the oil pump gears into Mopar® ATF+3, type 7176 transmission fluid and install into their original locations (See Figure 87).
7. Install the oil pump shuttle valve into the pump cavity shown in Figures 87 and 88.
8. Lubricate all valves that go into the pump cover with Mopar® ATF+3, type 7176 transmission fluid, as well as the pump cover valve bores.
9. Install all springs, valves and retainers *exactly* as shown in Figures 88 and 89. Notice that the valve line-up retainers are different sizes for different locations, shown in Figure 88 legend.
10. Refer to Figure 90 for the exact cavity location in the pump cover for the various retainers.

Continued on Page 68.

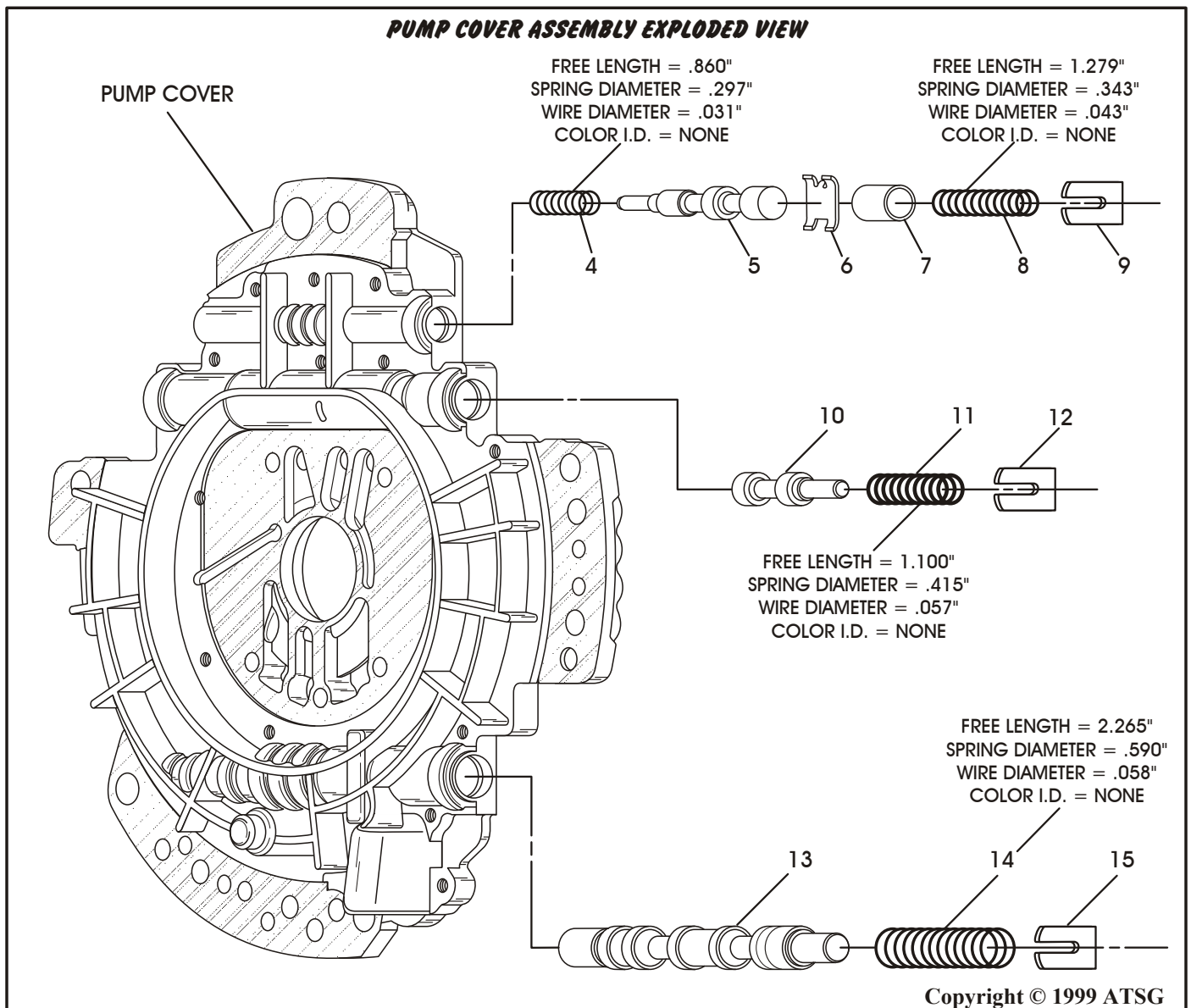

Figure 89

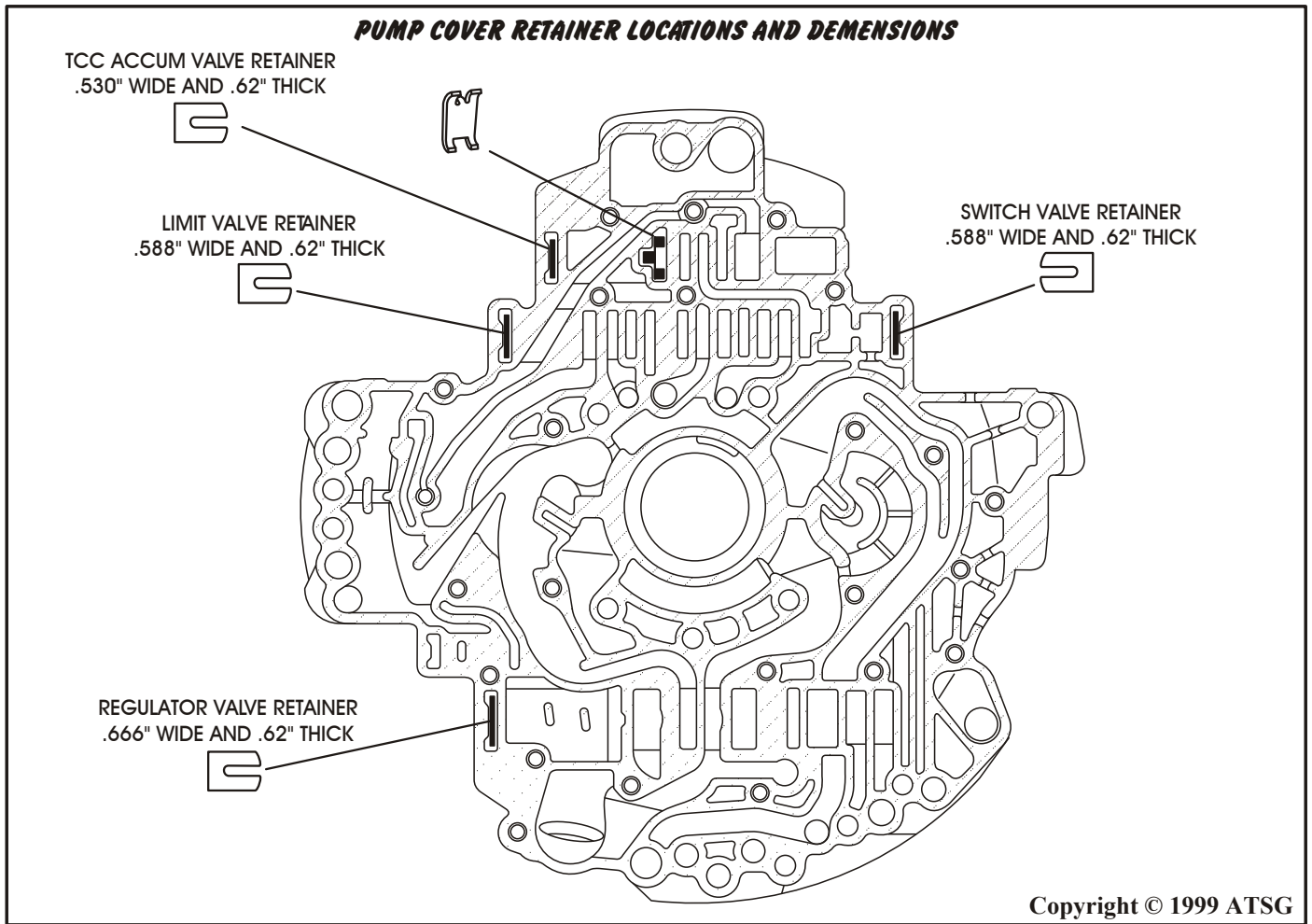

Figure 90

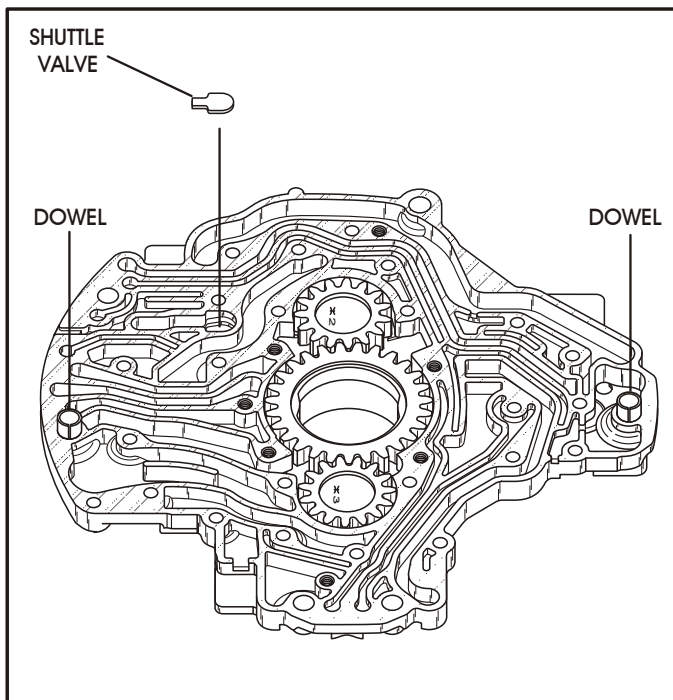

Figure 91

OIL PUMP AND COVER ASSEMBLY (Cont'd)

11. Ensure that the shuttle valve is installed into the proper cavity in the oil pump body, and that the dowels are installed as shown in Figure 91.
12. Install the oil pump spacer plate onto the pump body over the dowels as shown in Figure 92.
13. Install the two screws to retain the spacer plate on the pump and torque to 4.5 Nm (40 in lbs). Refer to Figure 92.
14. Install the pre-assembled oil pump cover onto the locating dowels as shown in Figure 93.
15. Seat the two oil pump halves together and very carefully turn the assembly over as shown in Figure 94. Start all 24 screws finger tight.
16. Torque all bolts slowly, starting in center and working out in a circle, to 4.5 Nm (40 in lbs). Refer to Figure 94.
17. Verify that the oil pump gears rotate freely.

Continued on Page 70.

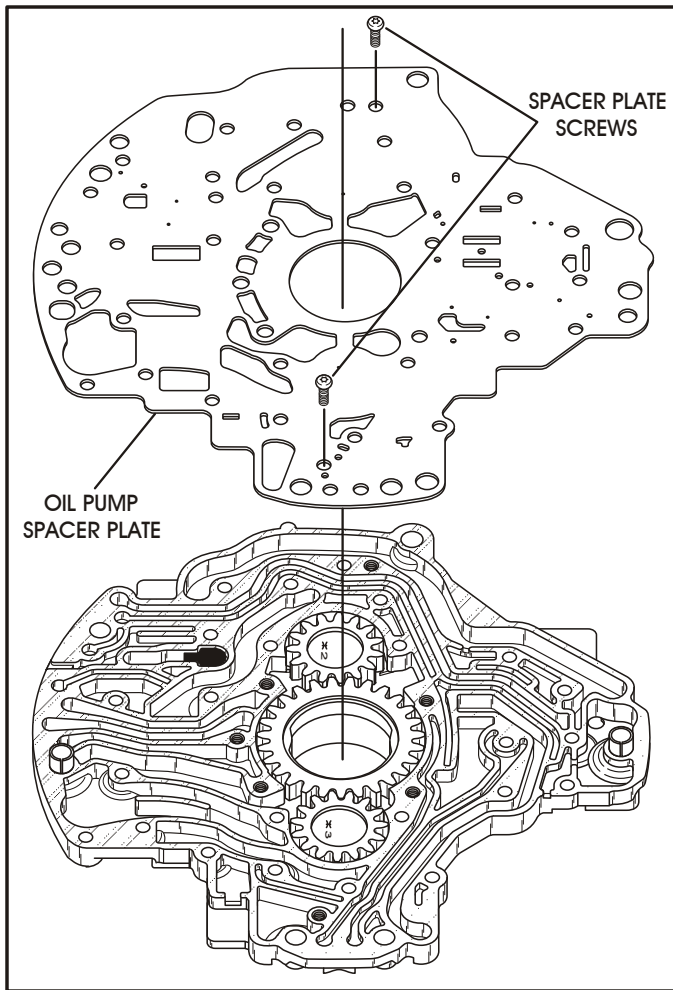

Figure 92

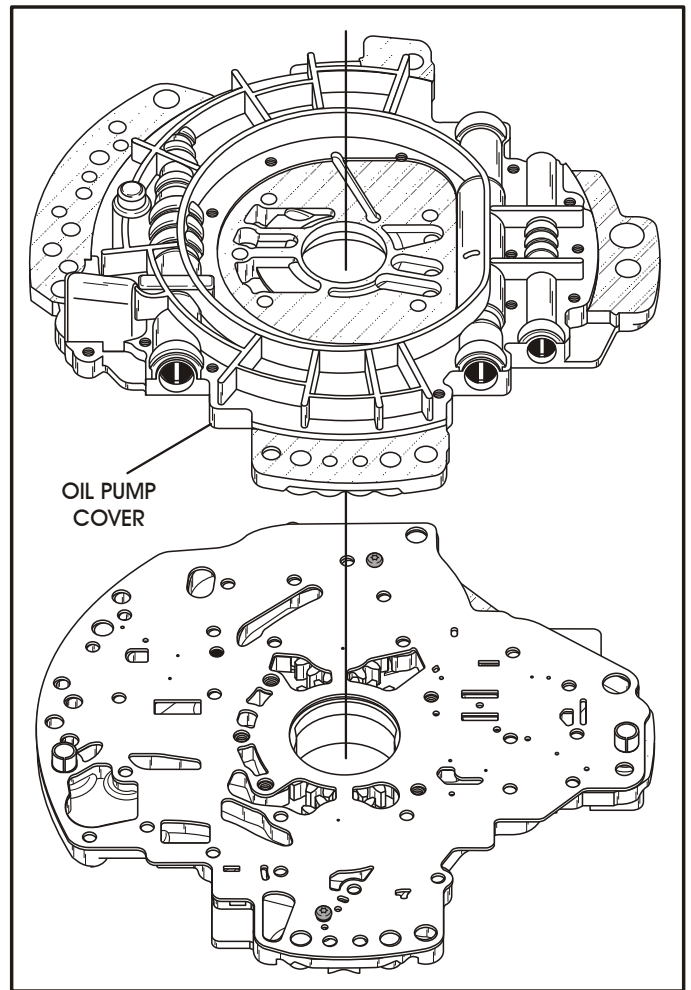

Figure 93

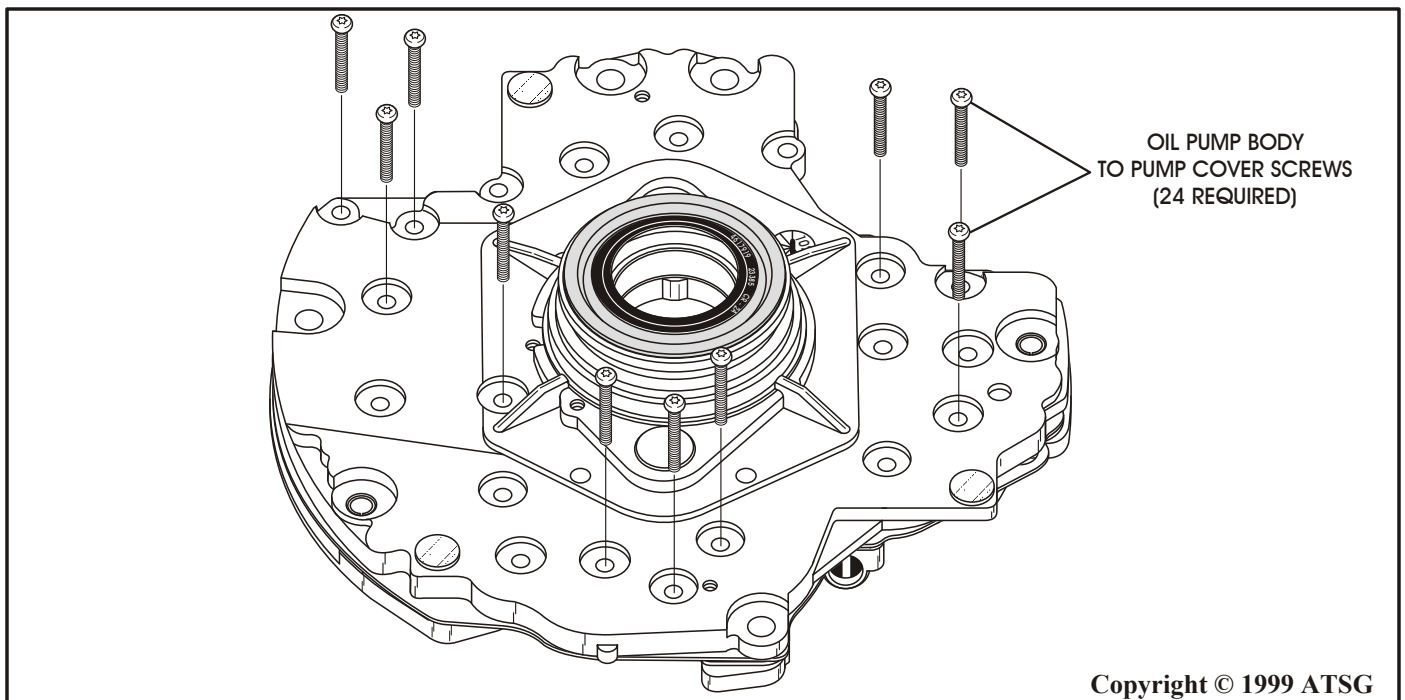

Figure 94

Copyright © 1999 ATSG

OIL PUMP AND COVER ASSEMBLY (Cont'd)

18. Install the stator shaft support into the oil pump assembly as shown in Figure 95.
19. Install the 5 bolts that hold the stator support to the oil pump assembly as shown in Figure 95.
20. Torque the 5 stator shaft support bolts down to 12 Nm (105 in lbs).
21. Install five new sealing rings on stator support in their respective grooves and ensure that they are properly hooked. Refer to Figure 96.
22. Set the completed oil pump assembly aside for the final assembly process (See Figure 97).

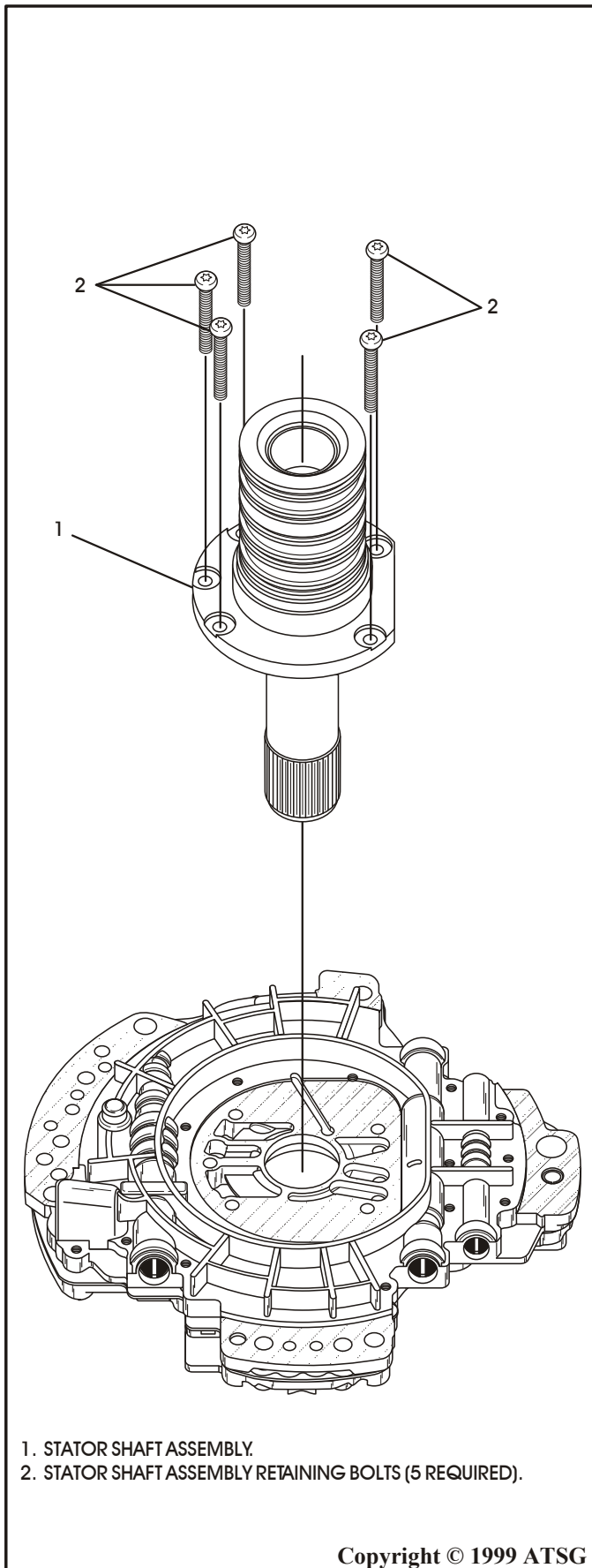
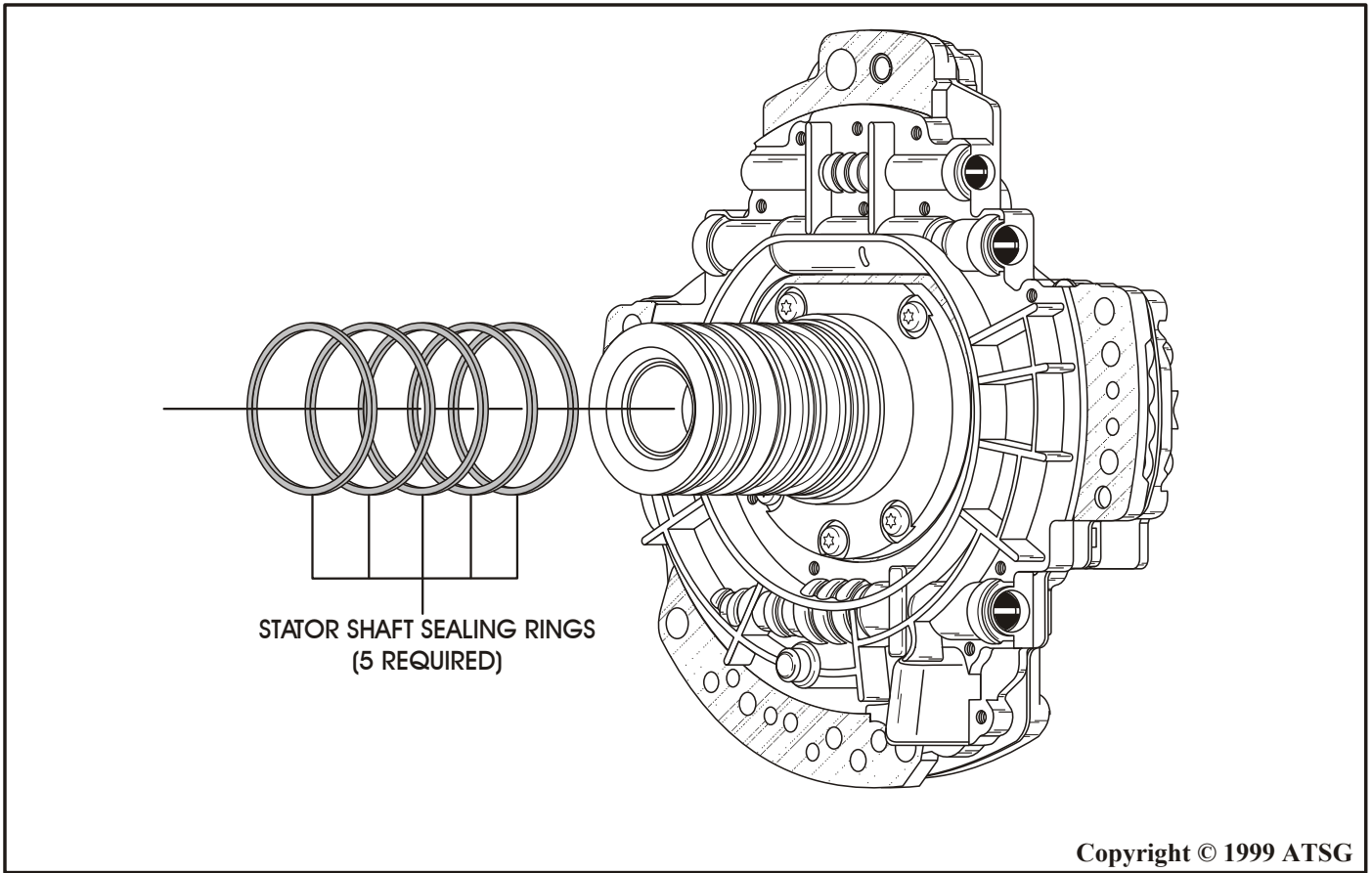
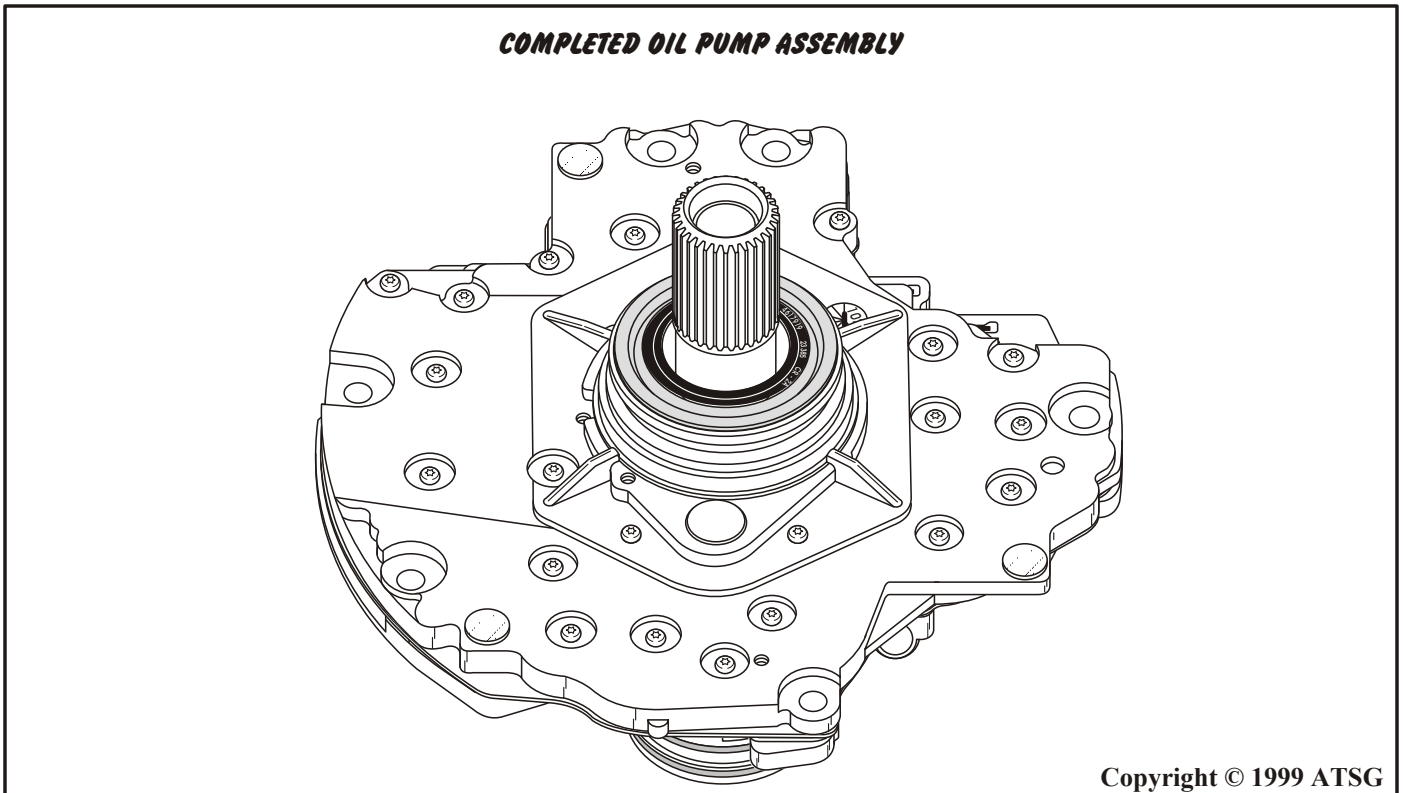

Figure 95



Copyright © 1999 ATSG

Figure 96



Copyright © 1999 ATSG

Figure 97

VALVE BODY ASSEMBLY EXPLODED VIEW

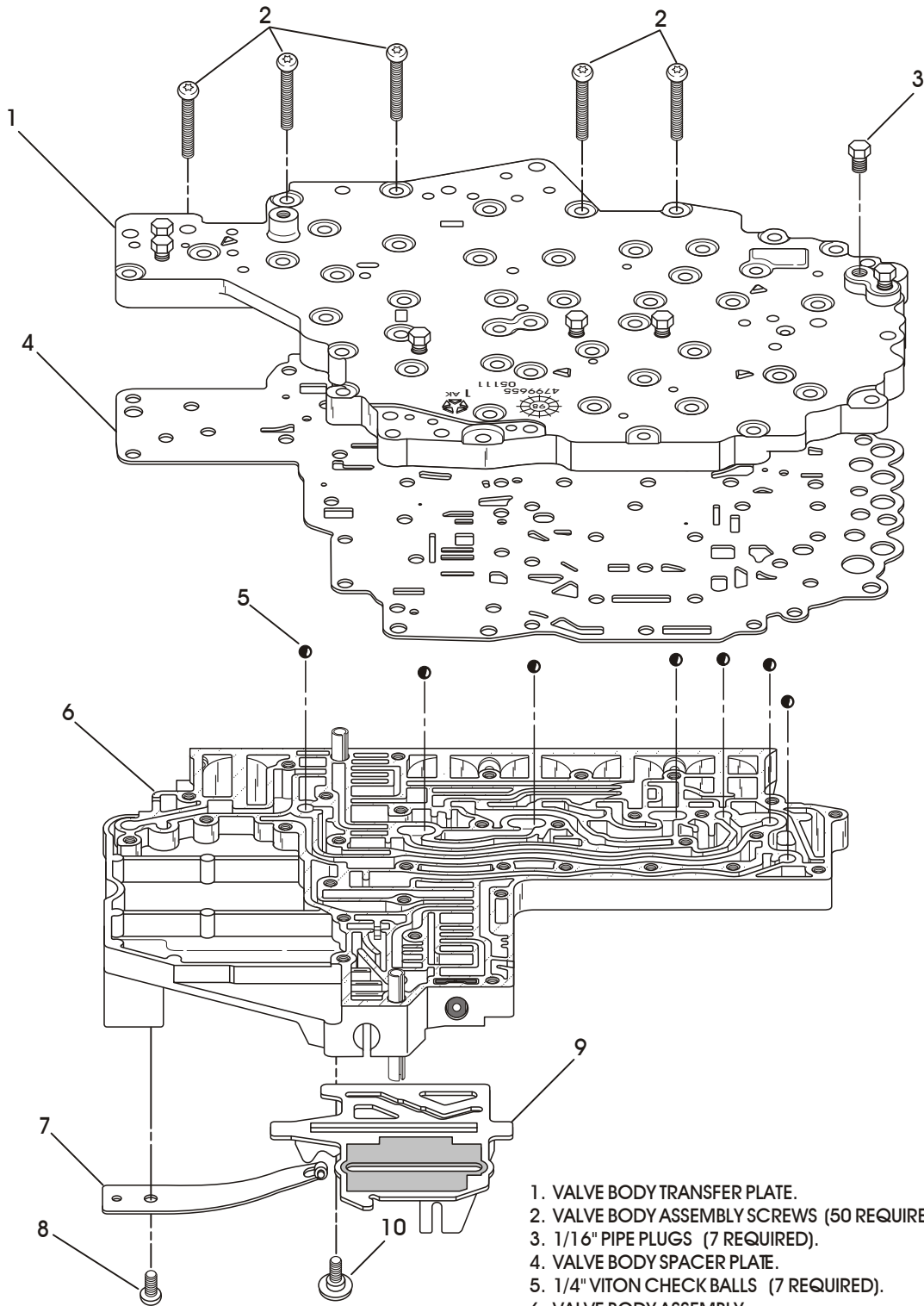

1. VALVE BODY TRANSFER PLATE.
2. VALVE BODY ASSEMBLY SCREWS (50 REQUIRED).
3. 1/16" PIPE PLUGS (7 REQUIRED).
4. VALVE BODY SPACER PLATE.
5. 1/4" VITON CHECK BALLS (7 REQUIRED).
6. VALVE BODY ASSEMBLY.
7. MANUAL VALVE DETENT SPRING.
8. MANUAL VALVE DETENT SPRING RETAINING BOLT.
9. TRANSMISSION RANGE SENSOR SELECTOR PLATE.
10. TRS SELECTOR PLATE "SHOULDERED" RETAINING BOLT.

Copyright © 1999 ATSG

Figure 98

VALVE BODY DISASSEMBLY

1. Remove the 15 screws that are shaded as shown in Figure 100. These screws must be removed **first**, so the TRS/Solenoid Body that contains most of the electrical components, will not be cleaned with any solvents.
2. **Do Not** remove the six screws from the top of the TRS/Solenoid Body (See Figure 99).
3. Once the TRS/Solenoid Body is separated from the valve body assembly, continue disassembly of the valve body using Figure 98 as a guide.
4. Notice in Figure 98 that the valve body contains seven checkballs. Care should be taken to keep the valve body in the position shown, when you are removing the transfer plate, so as not to lose any of the checkballs.

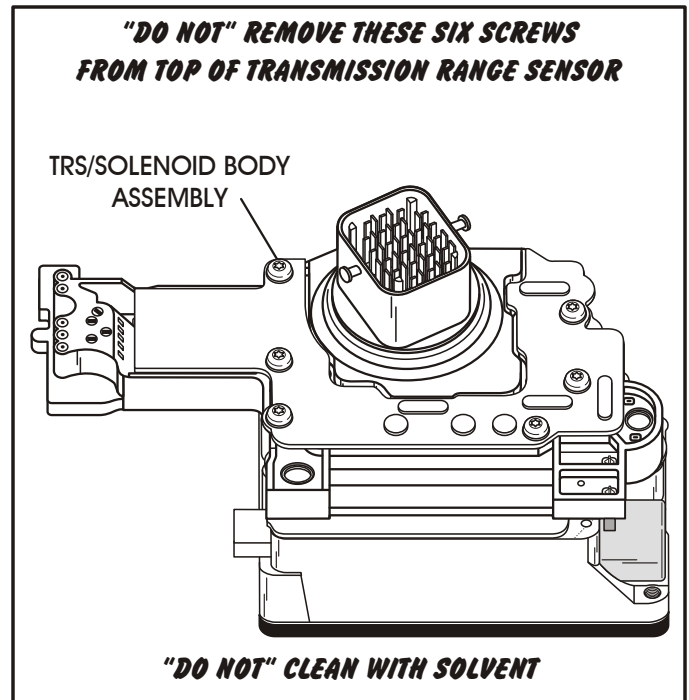

Figure 99

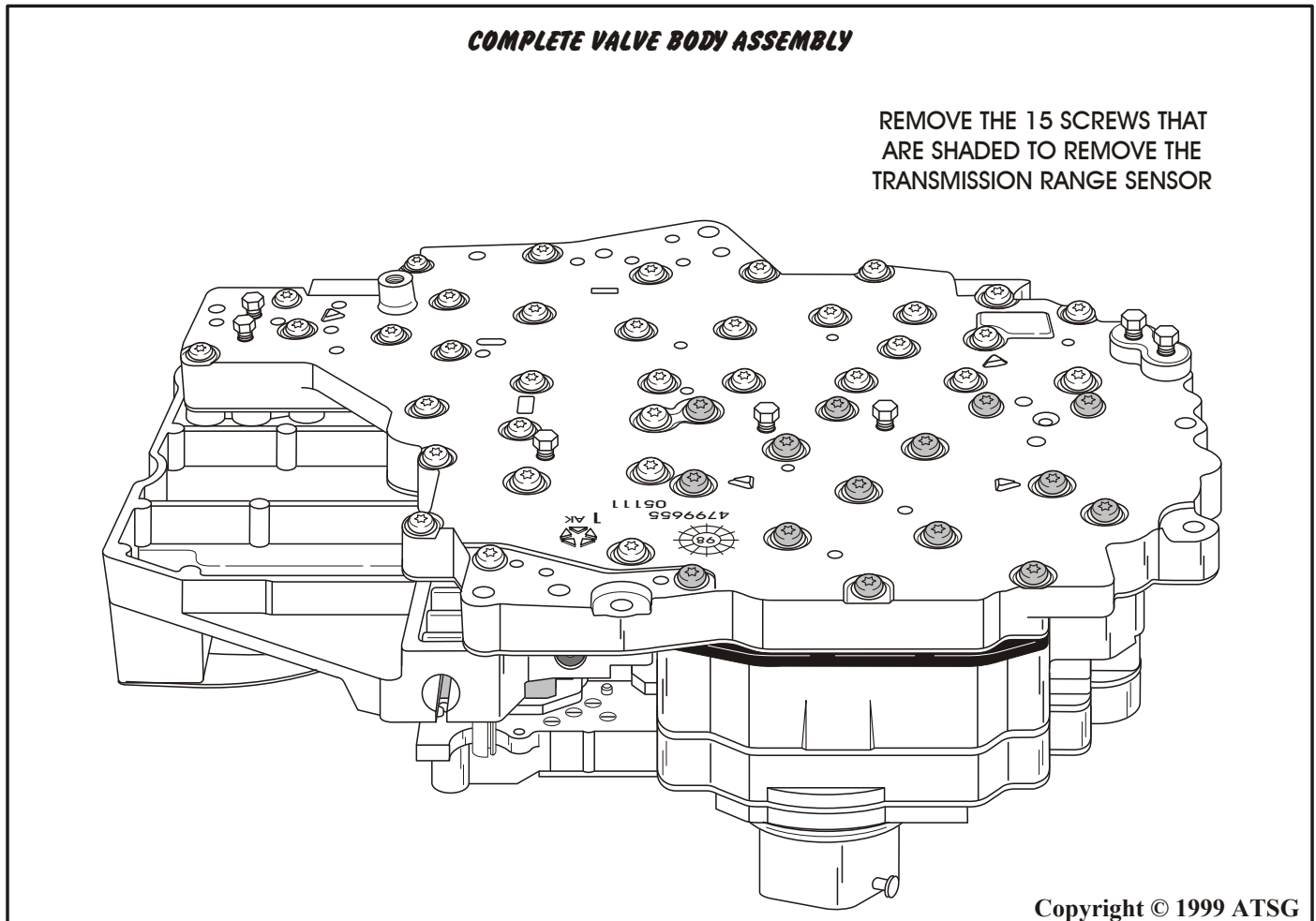
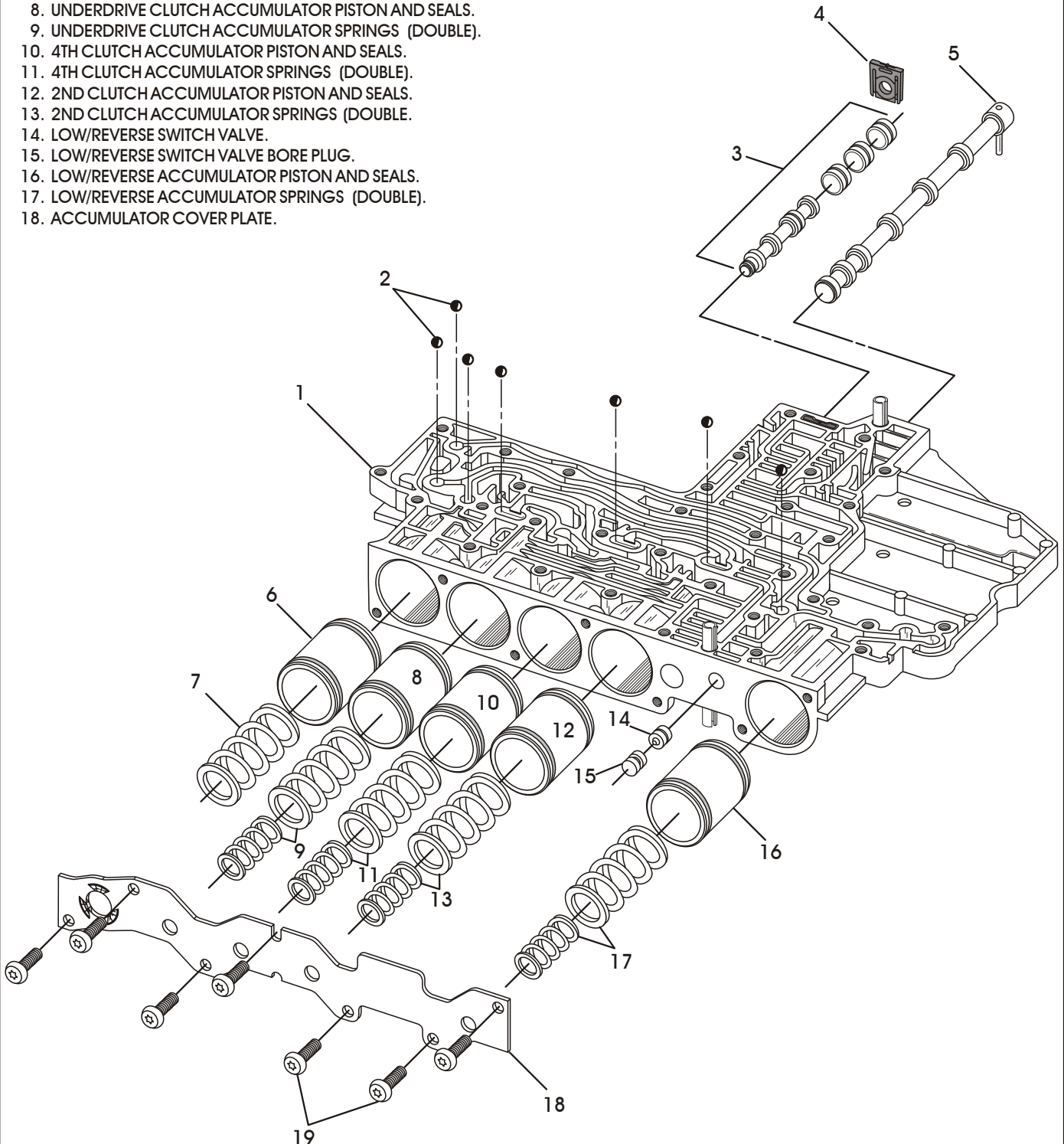

Figure 100

MAIN VALVE BODY EXPLODED VIEW

1. MAIN VALVE BODY CASTING.
2. 1/4" VITON CHECKBALLS (7 REQUIRED).
3. SOLENOID SWITCH VALVE LINE-UP
4. SOLENOID SWITCH VALVE LINE-UP PLASTIC RETAINING CLIP
5. MANUAL VALVE.
6. OVERDRIVE CLUTCH ACCUMULATOR PISTON AND SEALS.
7. OVERDRIVE CLUTCH ACCUMULATOR SPRING (SINGLE).
8. UNDERDRIVE CLUTCH ACCUMULATOR PISTON AND SEALS.
9. UNDERDRIVE CLUTCH ACCUMULATOR SPRINGS (DOUBLE).
10. 4TH CLUTCH ACCUMULATOR PISTON AND SEALS.
11. 4TH CLUTCH ACCUMULATOR SPRINGS (DOUBLE).
12. 2ND CLUTCH ACCUMULATOR PISTON AND SEALS.
13. 2ND CLUTCH ACCUMULATOR SPRINGS (DOUBLE).
14. LOW/REVERSE SWITCH VALVE.
15. LOW/REVERSE SWITCH VALVE BORE PLUG.
16. LOW/REVERSE ACCUMULATOR PISTON AND SEALS.
17. LOW/REVERSE ACCUMULATOR SPRINGS (DOUBLE).
18. ACCUMULATOR COVER PLATE.



Copyright © 1999 ATSG

Figure 98

VALVE BODY ASSEMBLY

1. Clean and inspect all components. Replace any parts that show evidence of wear or damage.
2. Lubricate the valves, springs and bore plugs with clean transmission fluid.
3. Install the solenoid switch valve and plugs into the valve body, exactly as shown in Figure 98, and then install the retainer.
4. Install the low/reverse switch valve into valve body as shown in Figure 98, followed by the bore plug. Some manuals illustrate a bore plug wire retainer for this location. Our unit did not have one, nor is it needed as the accumulator cover retains this valve train (See Figure 98).
5. Install the accumulator pistons and springs into the valve body in their proper locations, shown in Figure 98. Notice that all accumulators have two springs, except the overdrive, which has only one. Refer to Figure 98.
6. Install the accumulator cover onto valve body using the 7 retaining screws (See Figure 98).
7. Torque the screws to 4.5 Nm (40 in lbs).
8. Ensure that the solenoid switch valve and the low/reverse switch valve are free in their bores.
9. Lay the valve body down on a flat surface and install the 7 checkballs into the proper pockets as shown in Figure 99.

Continued on Page 77.

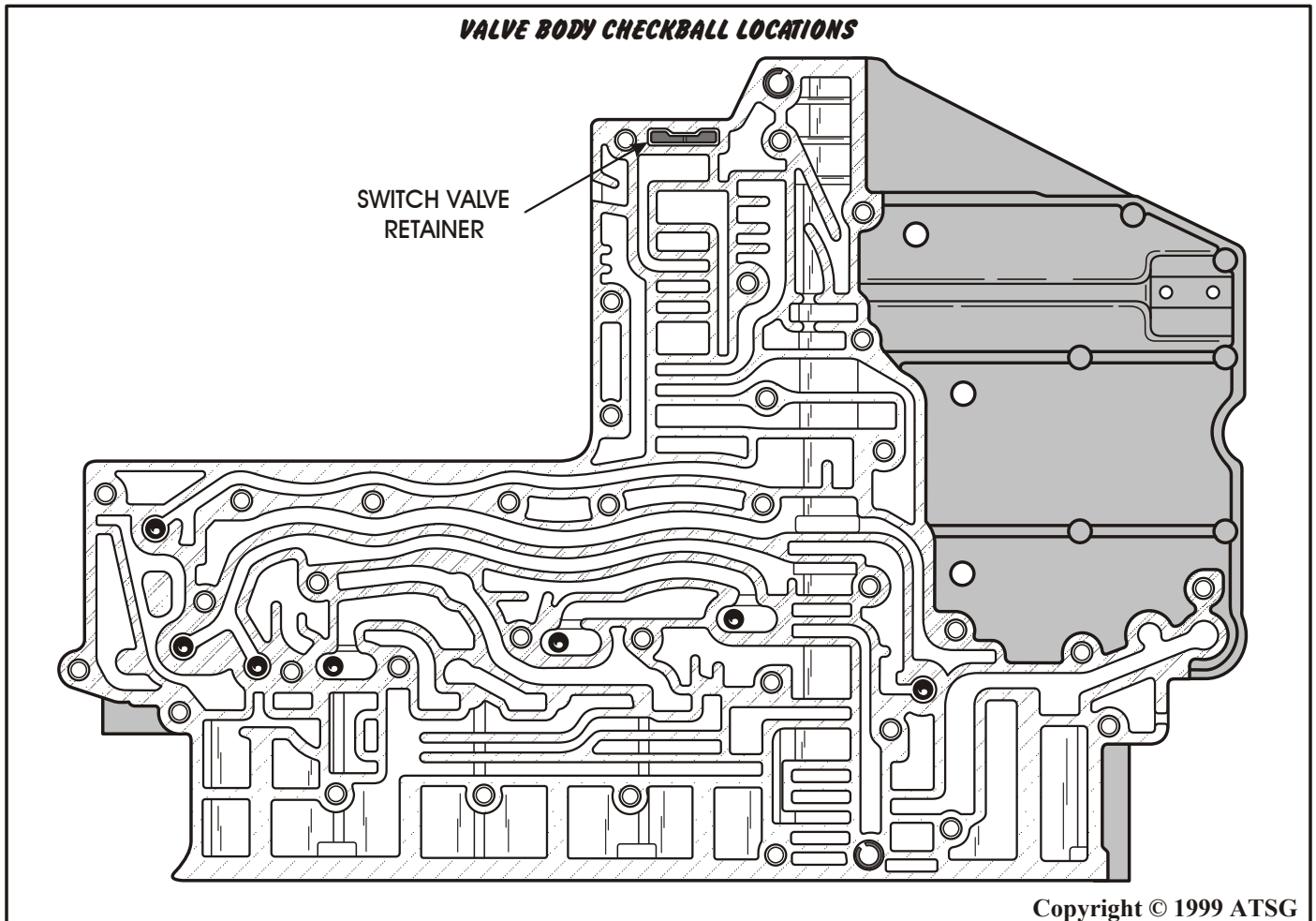

Figure 99

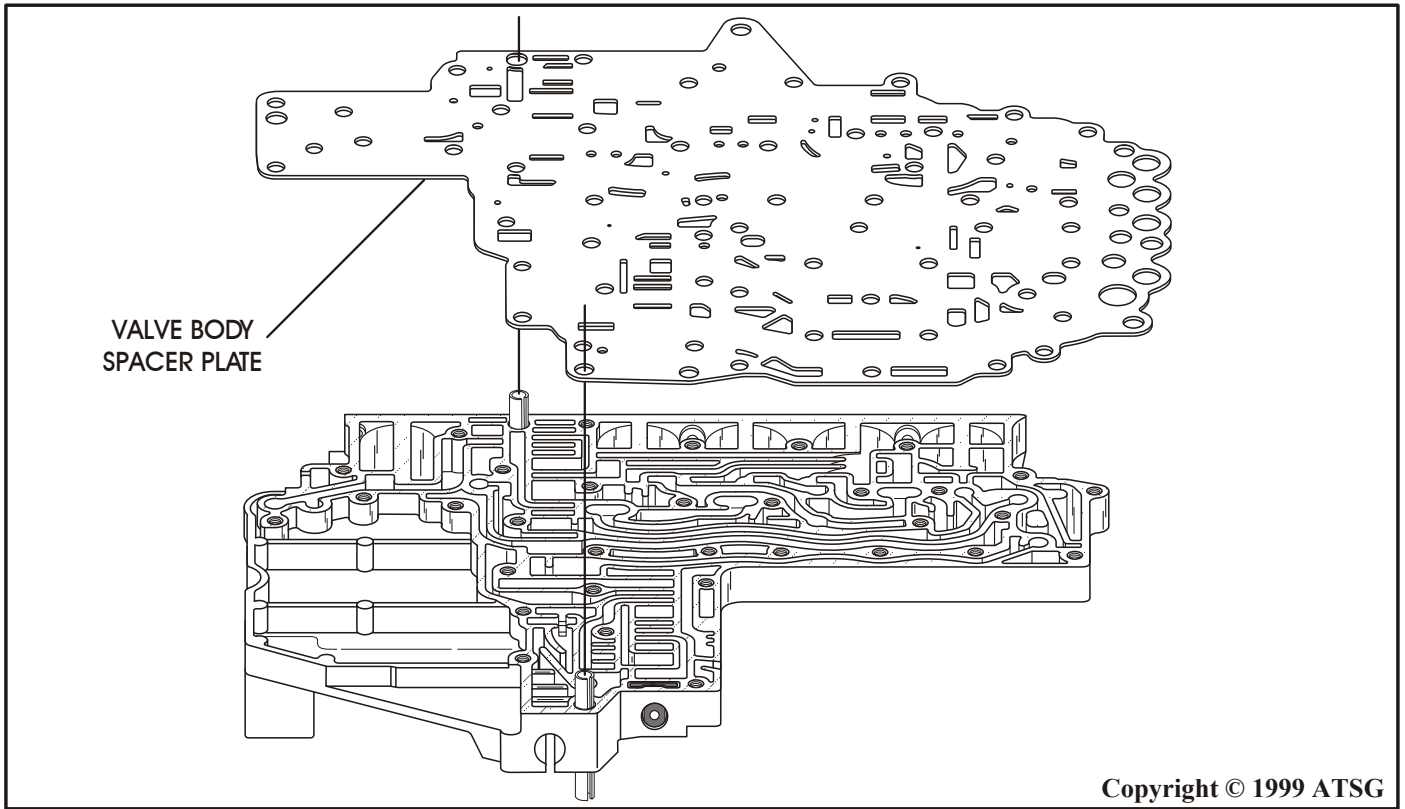

Figure 100

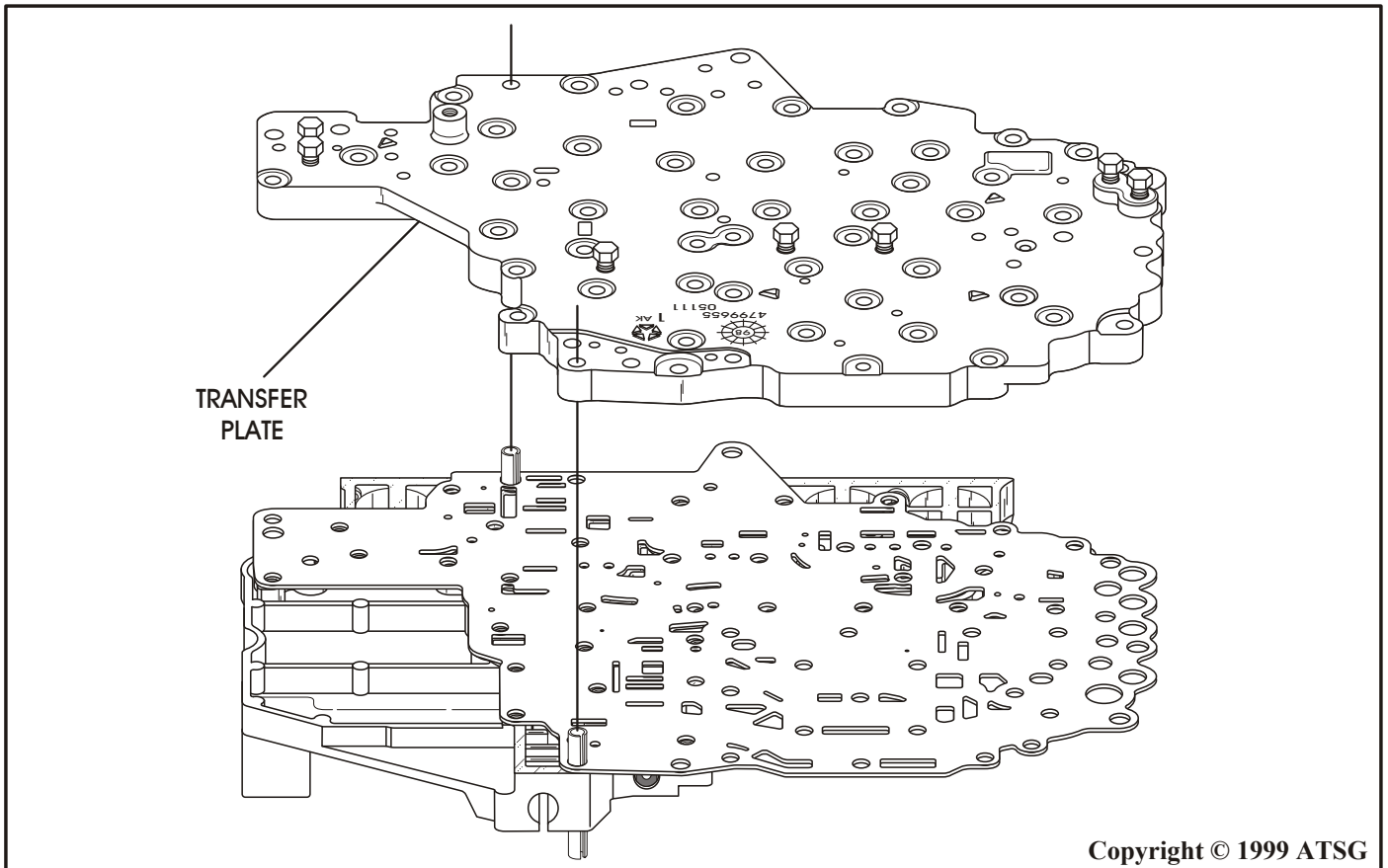

Figure 101

VALVE BODY ASSEMBLY (Cont'd)

10. Install the valve body spacer plate over the locating dowels and onto the valve body as shown in Figure 100.
11. Install the transfer plate over locating dowels on the valve body as shown in Figure 101.
12. Install the 35 valve body to transfer plate bolts in the locations shown in Figure 102.
13. Torque the valve body to transfer plate bolts to 4.5 Nm (40 in lbs).
14. Turn the assembly over to continue assembly process.

Continued on Page 78.

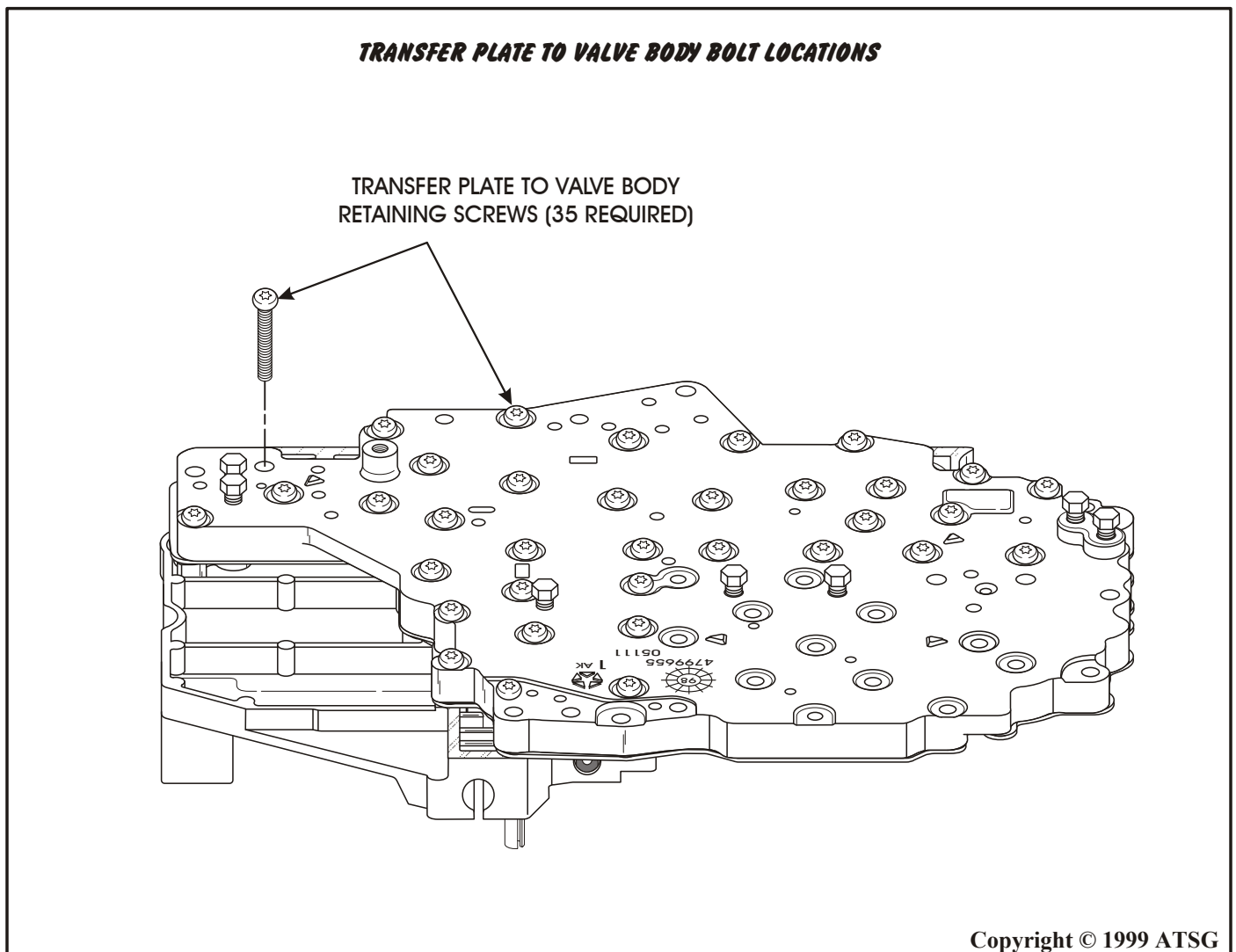
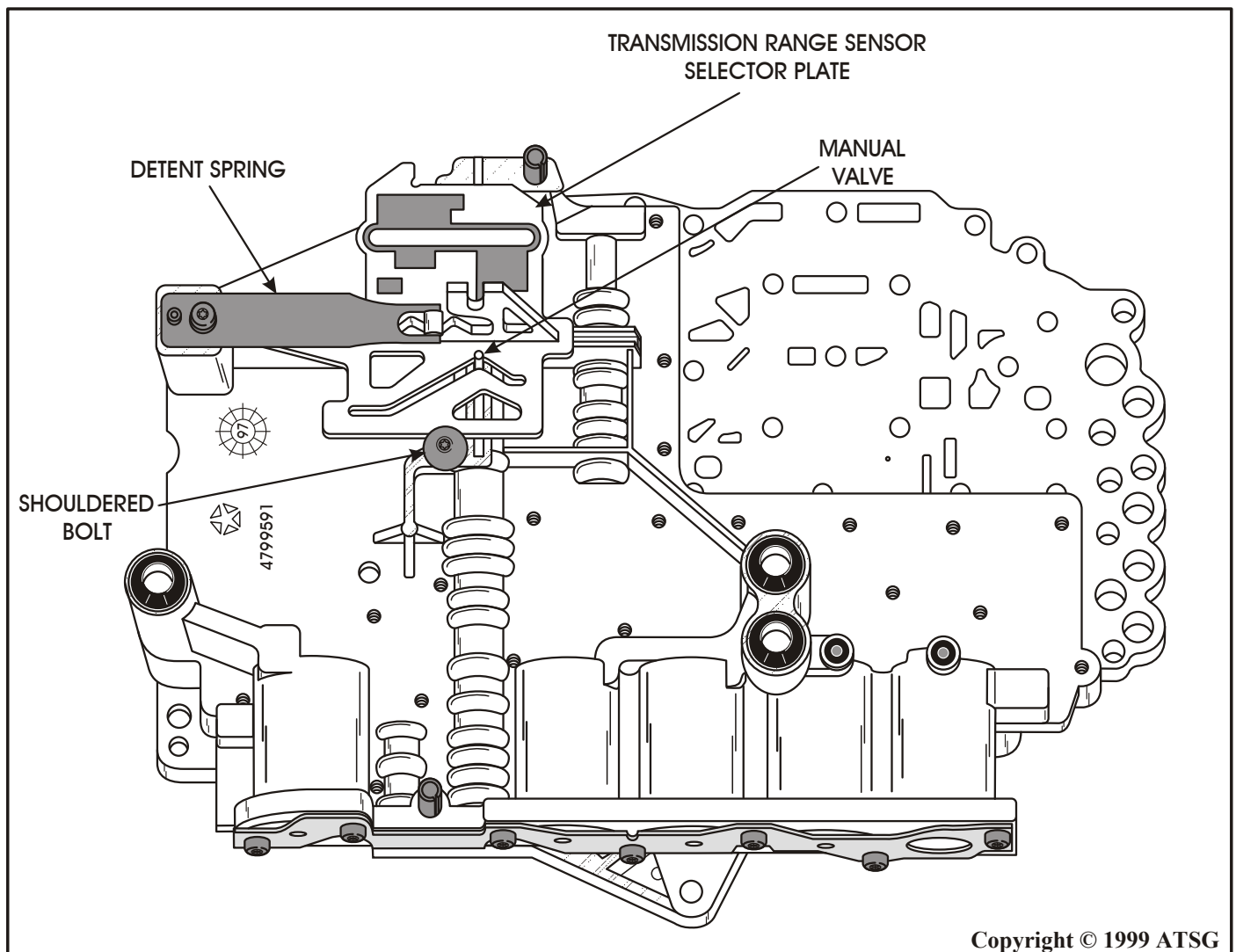

Figure 102

VALVE BODY ASSEMBLY (Cont'd)

15. Install the manual valve into the manual valve bore in the valve body with the stem facing up and engaged in the groove (See Figure 103).
 16. Install the transmission range sensor selector plate into the groove in the valve body and over the stem on the manual valve (See Figure 103).
 17. Install the shouldered retaining bolt for the transmission range sensor selector plate and torque the bolt to 4.5 Nm (40 in lbs). Refer to Figure 103.
 18. Install the manual valve detent spring and bolt and torque bolt to 4.5 Nm (40 in lbs). Refer to Figure 103.
 19. Install the low/reverse seal into the valve body with the "house-top" facing up, as shown in Figure 104.
 20. Install a new 2nd clutch seal and 4th clutch seal into the valve body with the "house-top" facing up, as shown in Figure 104.
 21. Install the TRS/Solenoid Pack onto the transfer plate using the remaining 15 valve body screws as shown in Figure 105.
 22. Torque the TRS/Solenoid Pack screws down to 5.7 Nm (50 in lbs).
- Important: Tighten the screws nearest the TRS selector plate first, and work toward the other end. Refer to Figure 105.**
23. Testing procedures for the TRS/Solenoid Pack are found on Pages 18 and 19.
 24. Set the completed valve body assembly aside for the final assembly process.



Copyright © 1999 ATSG

Figure 103

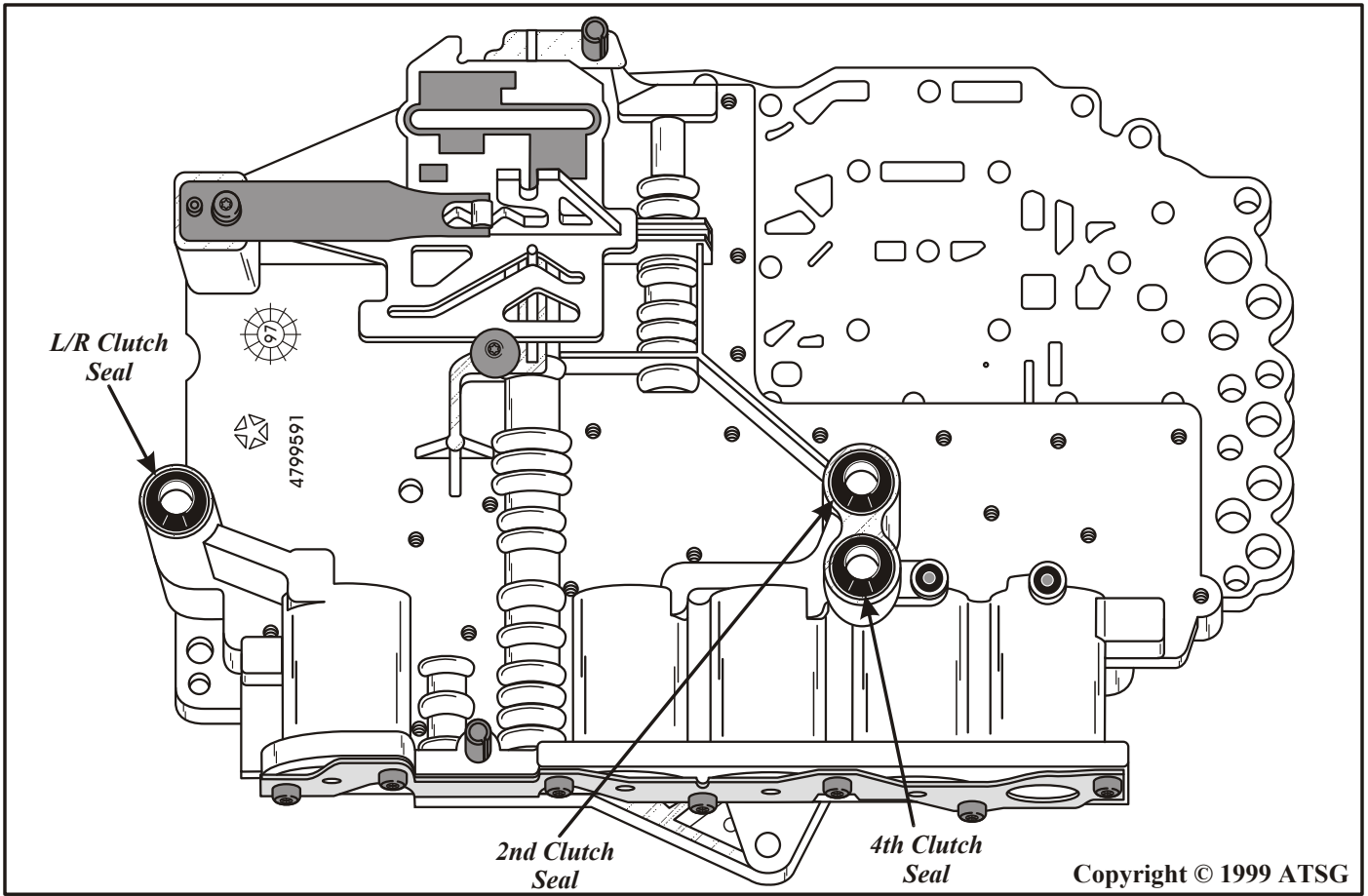

Figure 104

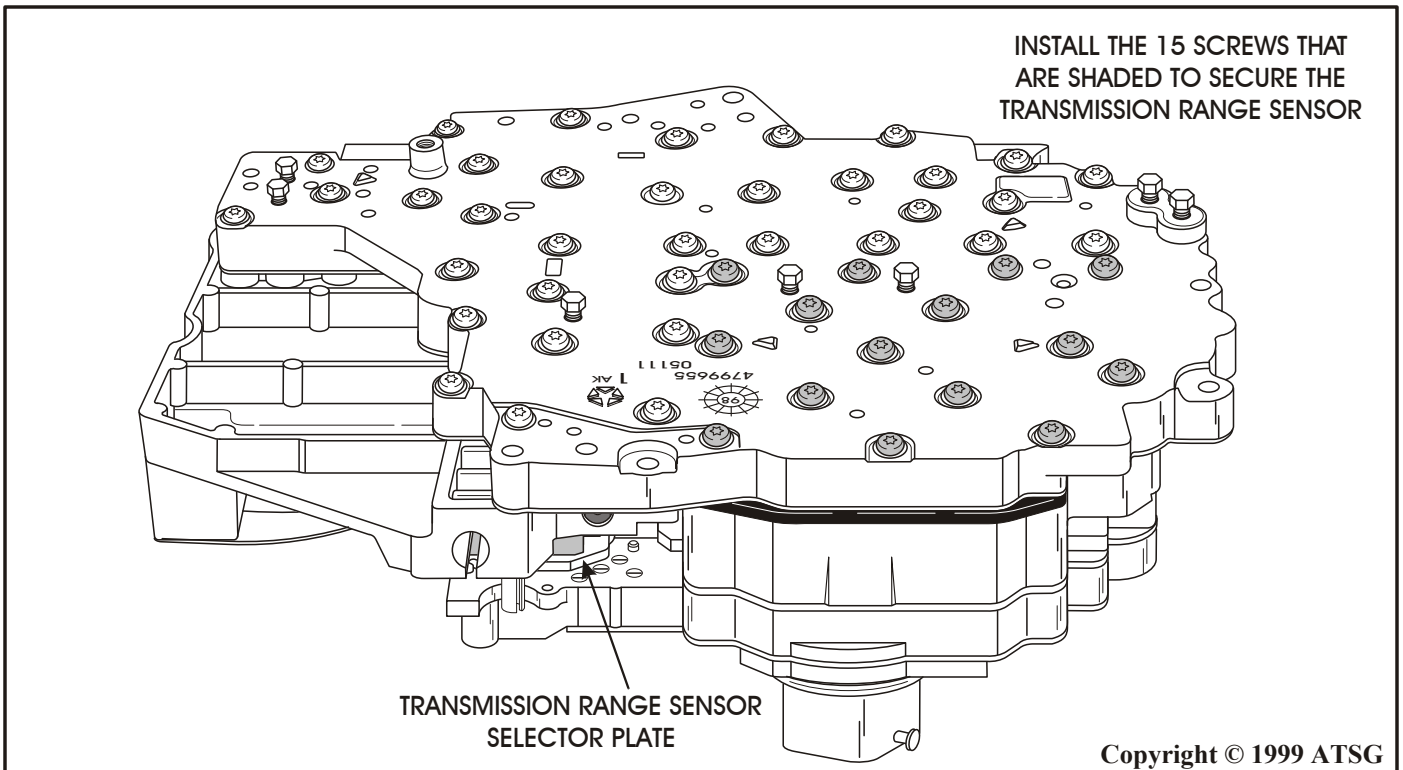

Figure 105

TRS/SOLENOID PACK

1. The TRS/Solenoid Pack is serviced *only* as a complete assembly, which is why we told you not to remove the screws on top that retain the cover plate.
2. However, if someone has not listened, we have provided you with an exploded view of the TRS/Solenoid Pack in Figures 105 and 106.

The illustrations in Figures 105 and 106 have been provided as information only. We recommend that the TRS/Solenoid Pack NOT be disassembled as none of the internal parts are serviced separately.

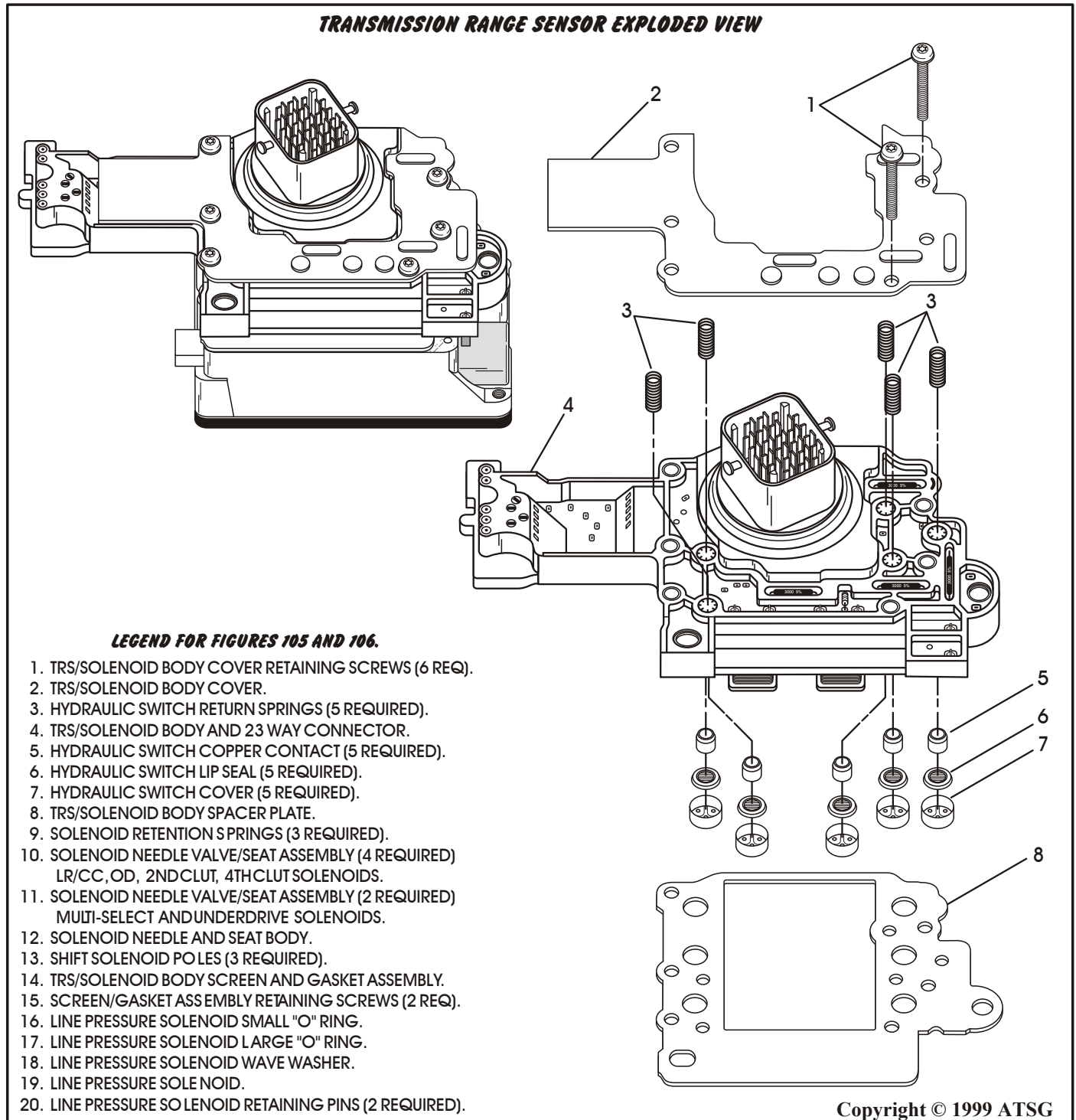
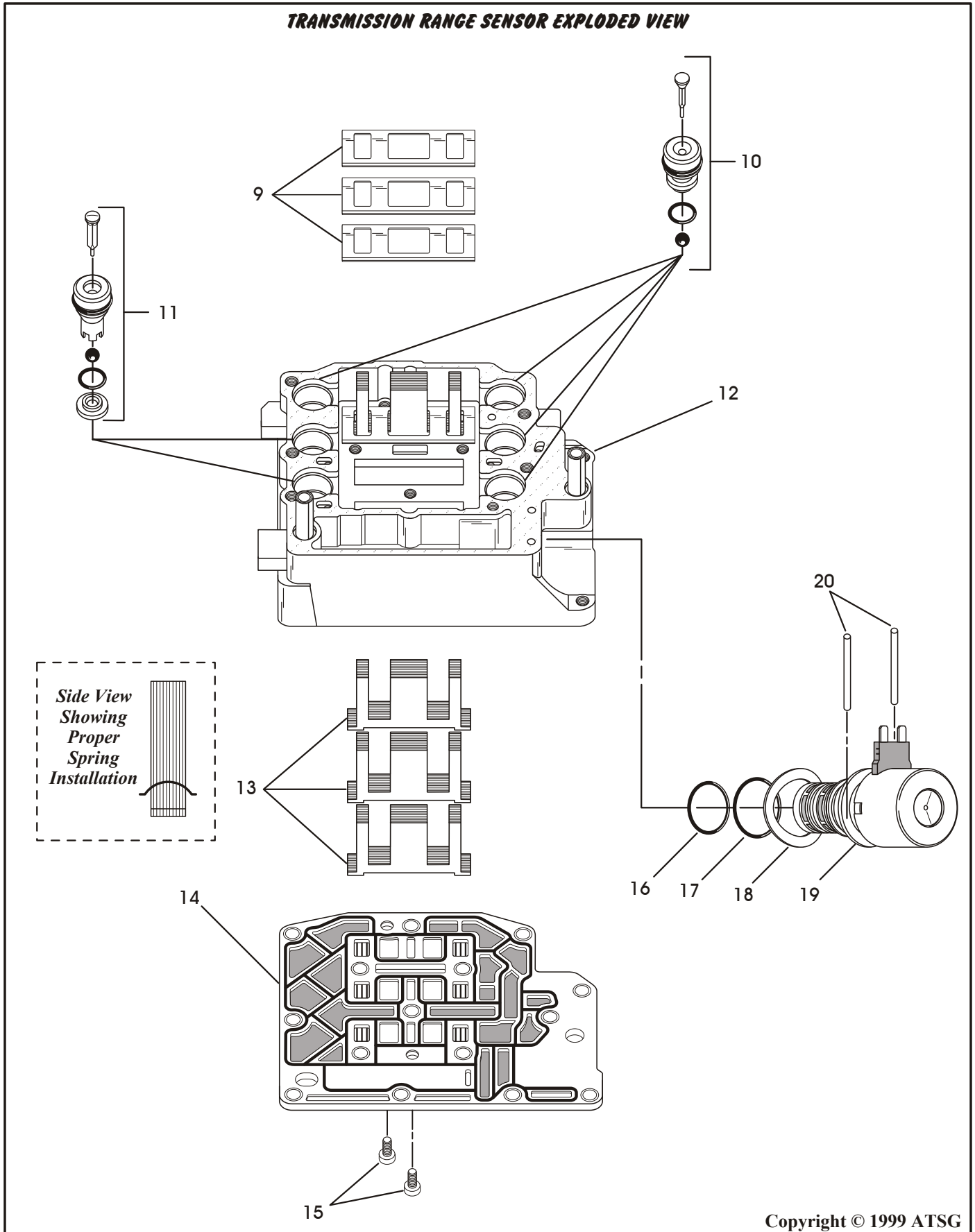

Figure 106

TRANSMISSION RANGE SENSOR EXPLODED VIEW



Copyright © 1999 ATSG

Figure 107

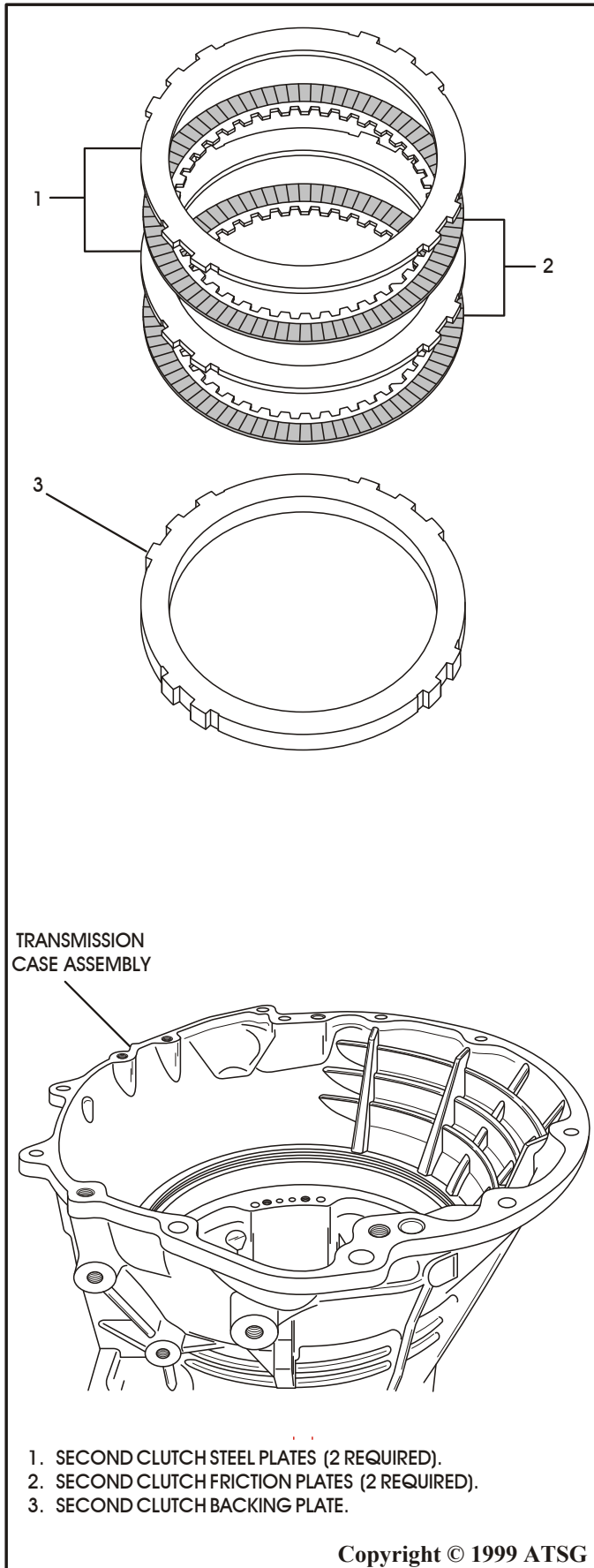

Figure 108

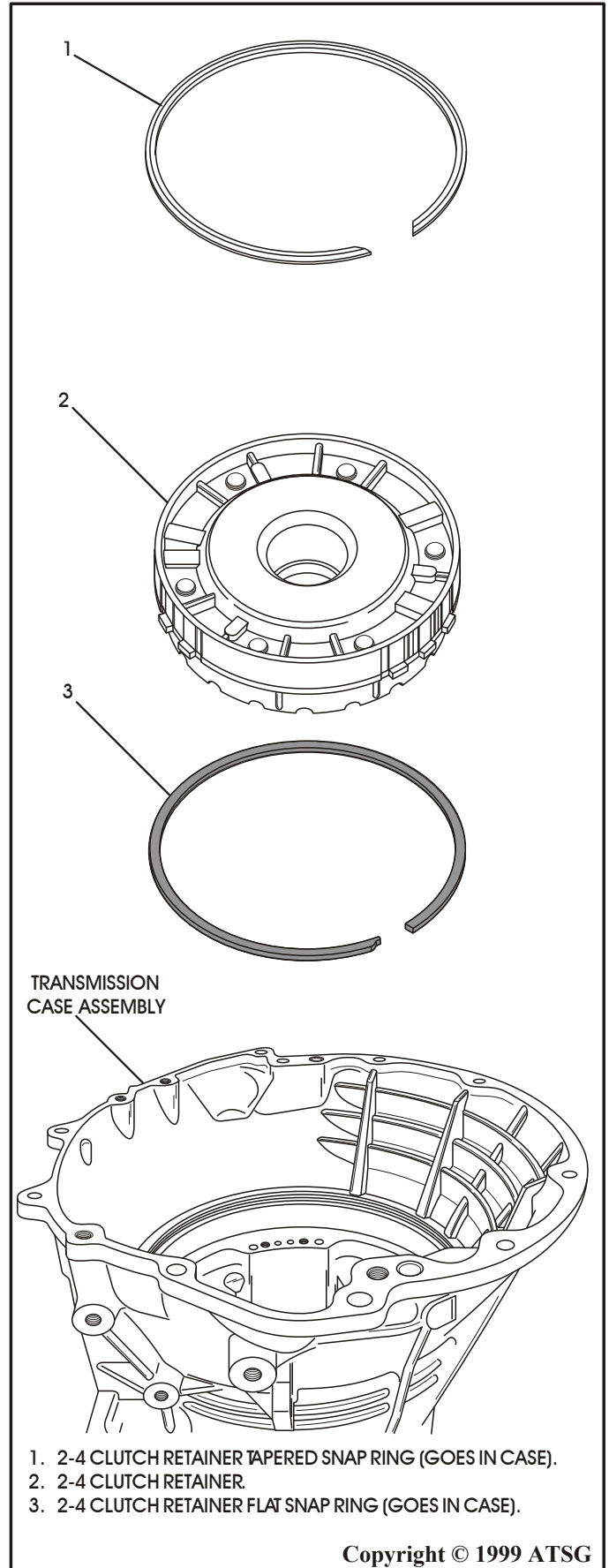

Figure 109

FINAL TRANSMISSION ASSEMBLY

1. The 2nd clutch must be installed temporarily as this is the only way to gauge clutch clearance.
2. Install the 2nd clutch backing plate into the transmission case as shown in Figure 108.
3. Install the 2nd clutch pack that you are going to use, beginning with a lined plate and alternating with steel plates until you have installed 2 lined plates and 2 steel plates (See Figure 108).
4. Install the 2-4 clutch retainer *flat* snap ring into the transmission case as shown in Figure 109.
5. Install the 2-4 clutch retainer assembly into the transmission case with the oil feed holes toward the valve body area as shown in Figure 109.
6. Install the 2-4 clutch retainer *tapered* snap ring into the transmission case. Ensure that the snap ring open ends are located toward the valve body area. Refer to Figures 109 and 110.
7. Using a feeler gauge through rear case opening, measure the 2nd clutch pack clearance between the 2nd clutch backing plate and the trans case at 4 different points 90 degrees apart, as shown in Figure 110.
8. The average of these measurements is the 2nd clutch pack clearance. The 2nd clutch backing plate is selective to set proper clearance.
9. The correct 2nd clutch pack clearance should be 0.53-1.27 mm (.021"-.050").
10. Change the backing plate as necessary to set the proper clearance and re-measure the clearance to verify the selection.
11. Remove the 2-4 retainer and all the 2nd clutch components from the transmission case.

Continued on Page 84.

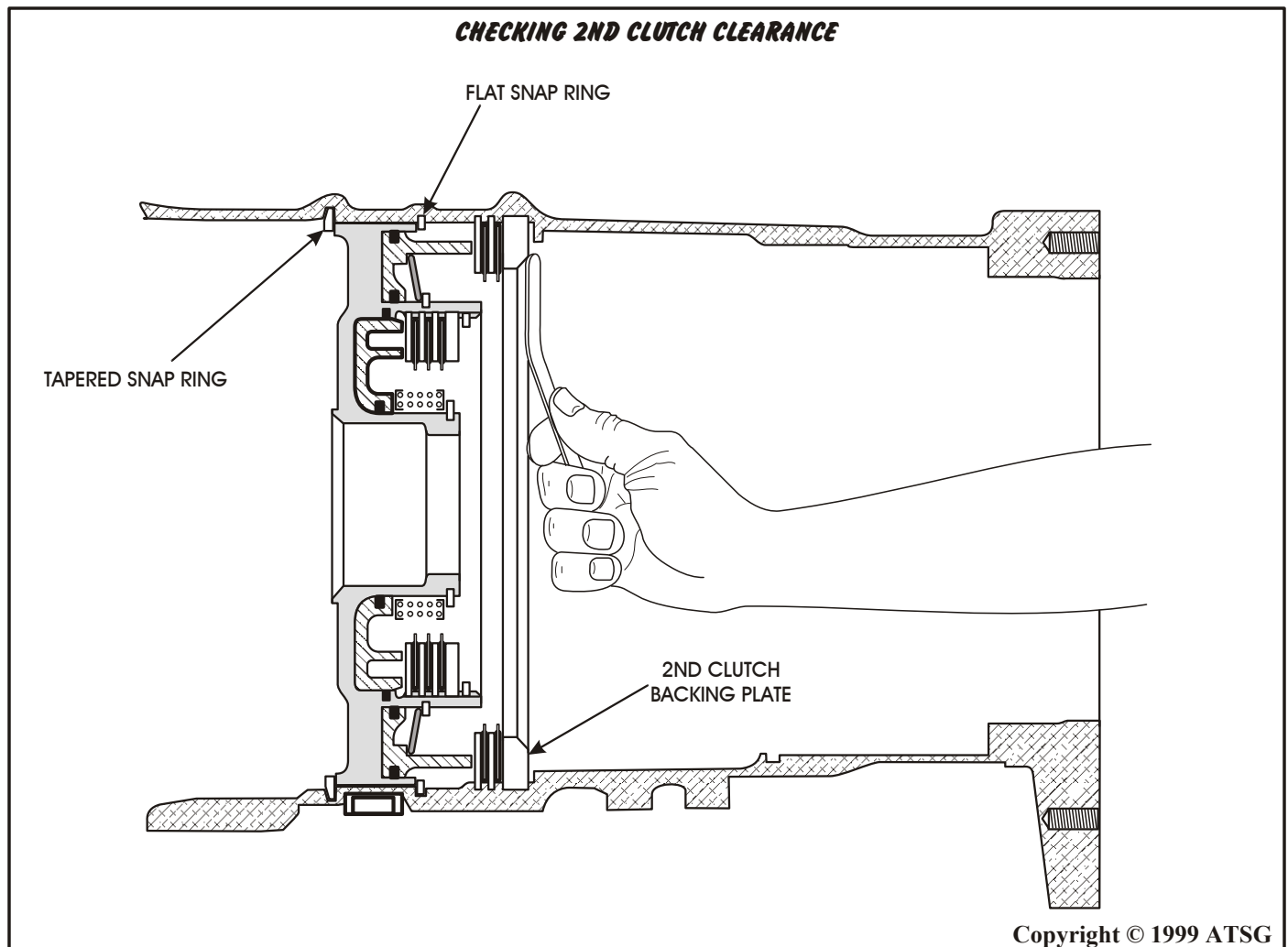

Figure 110

FINAL TRANSMISSION ASSEMBLY (Cont'd)

12. Install the low/reverse clutch housing into the transmission case as shown in Figure 111. The clutch housing has one lug that is wider than all the rest to orient it in the case with the feed hole toward the valve body.
13. Install the *tapered* snap ring into the groove in the case just above the low/reverse housing and ensure that it is fully seated (See Figure 111).
14. Install the number 12 thrust bearing assembly onto the low/reverse clutch housing with the inside tabs facing down (See Figure 112).
15. Install the input internal ring gear assembly as shown in Figure 112 and ensure that the lugs are engaged onto the low roller outer race.
16. Air check the low/reverse clutch pack and also verify low roller clutch for correct operation.
17. Install input carrier/reverse internal ring gear as shown in Figure 113, by rotating into position, to engage the teeth on input internal ring gear.
18. Install the number 11 thrust bearing assembly into the input carrier in the direction shown in Figure 113.

Continued on Page 85.

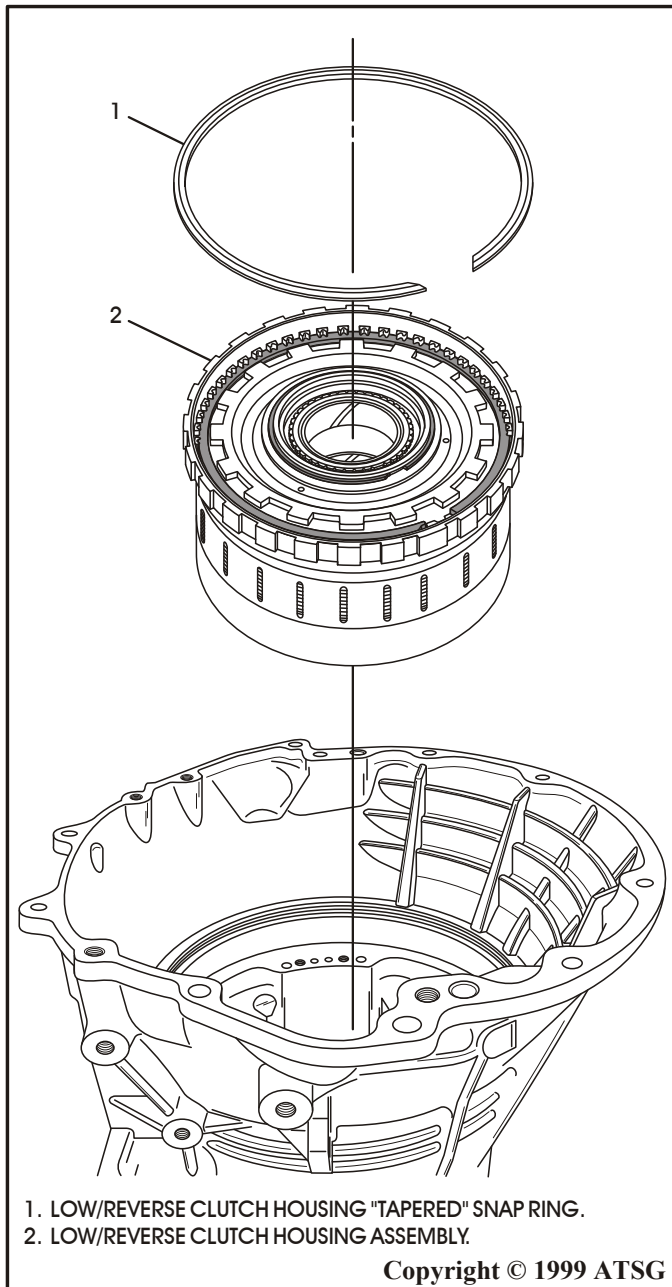

Figure 111

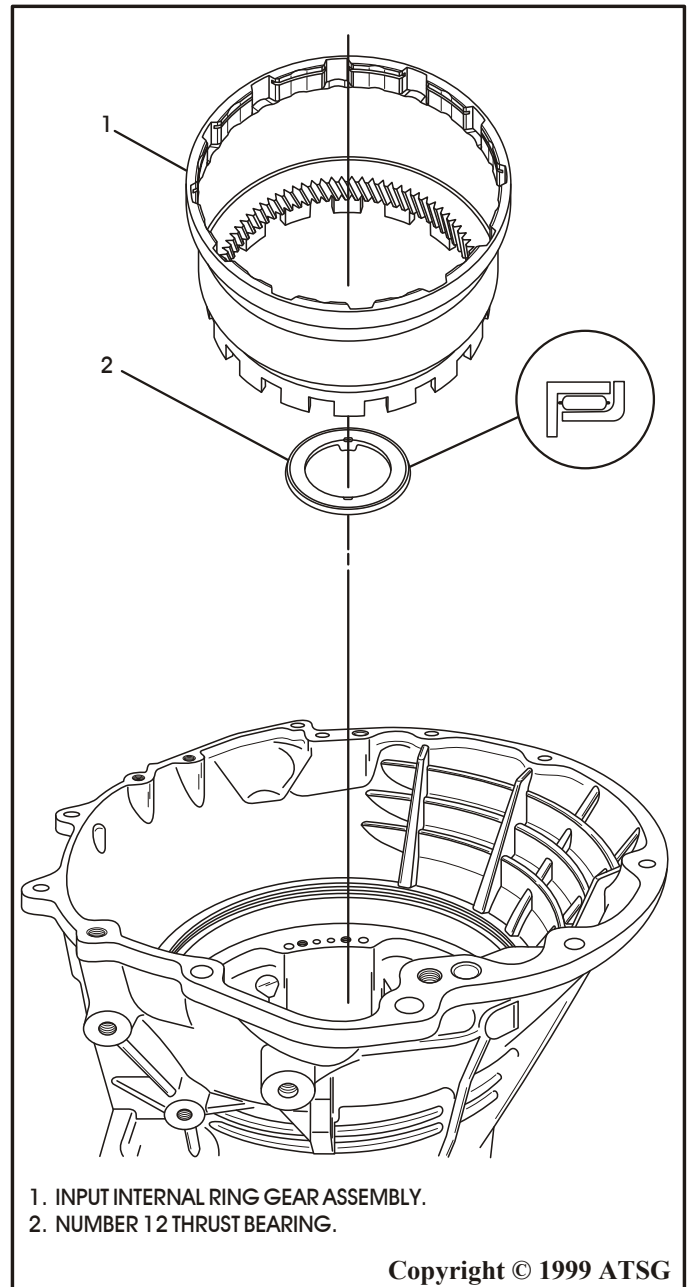

Figure 112

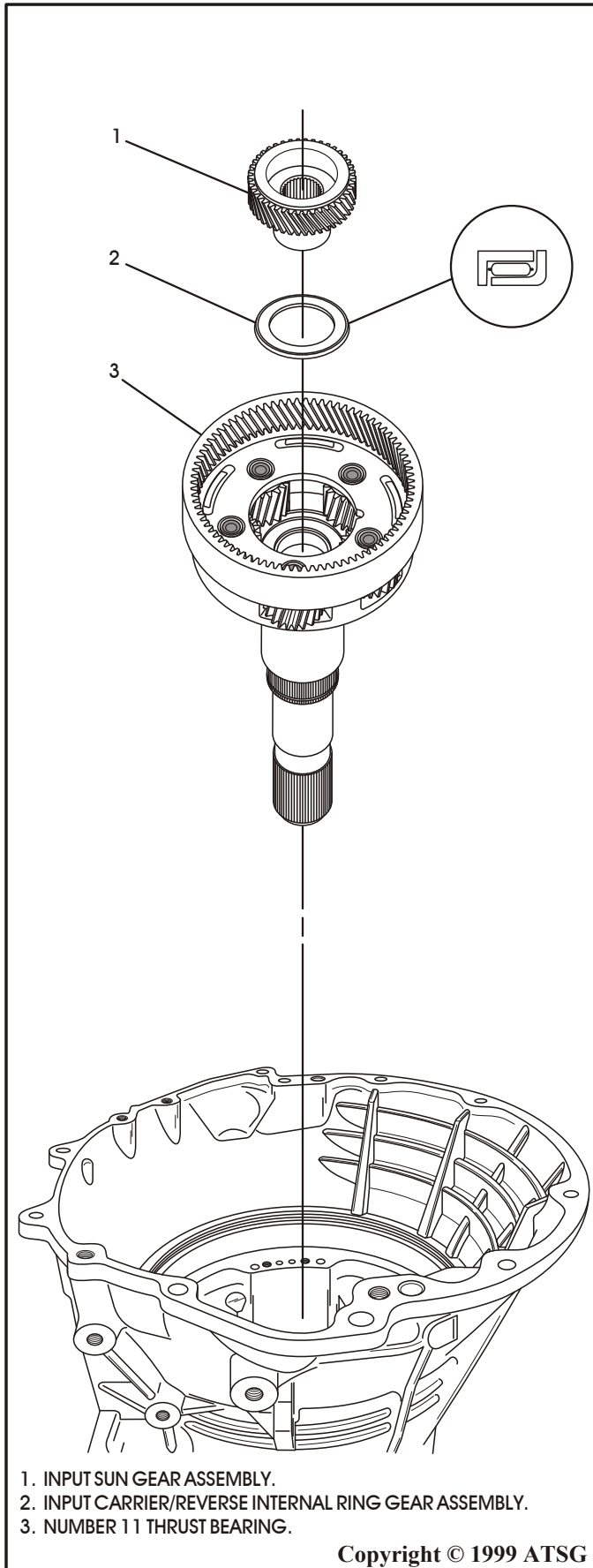

Figure 113

FINAL TRANSMISSION ASSEMBLY (Cont'd)

19. Install the input sun gear assembly, as shown in Figure 113, by rotating into position.
20. Install the number 10 thrust bearing assembly onto the reverse planetary carrier in direction shown in Figure 114, and retain with a small amount of TransJel®.
21. Install the reverse planetary carrier assembly in the transmission by rotating into position so as to engage the planet pinions and the carrier tabs into the input internal gear.
22. Install the reverse carrier/input ring gear *flat* snap ring into the groove in the input internal ring gear (See Figure 114).

Continued on Page 86.

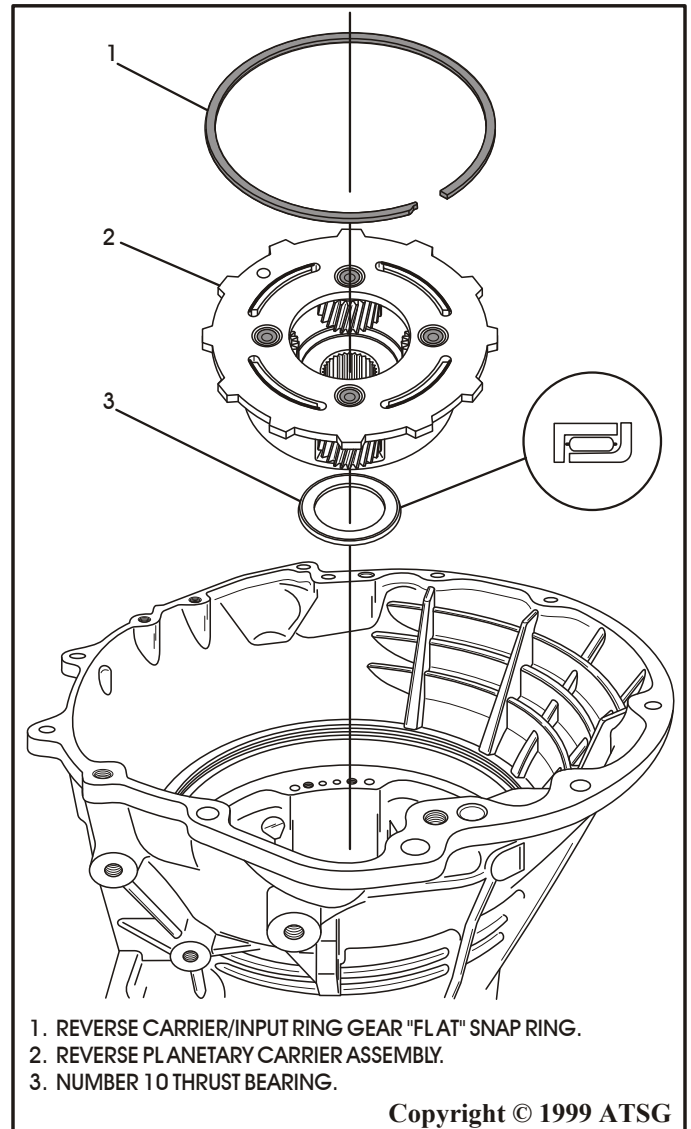

Figure 114

FINAL TRANSMISSION ASSEMBLY (Cont'd)

23. Install the number 9 thrust bearing onto to back side of the reaction carrier/reverse sun gear assembly, in the direction shown in Figure 115, and retain with a small amount of TransJel®.
24. Install the reaction carrier/reverse sun gear assembly, with bearing, into the transmission by rotating into position (See Figure 115).
25. Install the number 8 thrust bearing down inside of reaction carrier/reverse sun gear assembly in the direction shown in Figure 116.
26. Install the reaction sun gear in transmission by rotating into position (See Figure 116).
27. Install the number 7 thrust bearing into back side of the reaction internal gear, in direction shown in Figure 116, and retain with a small amount of TransJel®.
28. Install the reaction internal gear assembly into trans by rotating into position (See Figure 116).
29. Install rear selective plate on reaction ring gear with oil grooves facing down and engaged on tabs as shown in Figure 116.

30. Install the 2nd clutch backing plate into case as shown in Figure 117.
31. Install the 2nd clutch pack into case beginning with a lined plate and alternating with steels until you have installed 2 lined & 2 steel plates as shown n Figure 117.
32. Install the 2-4 clutch retainer *flat* snap ring into lower groove in the transmission case. Refer to Figure 118.

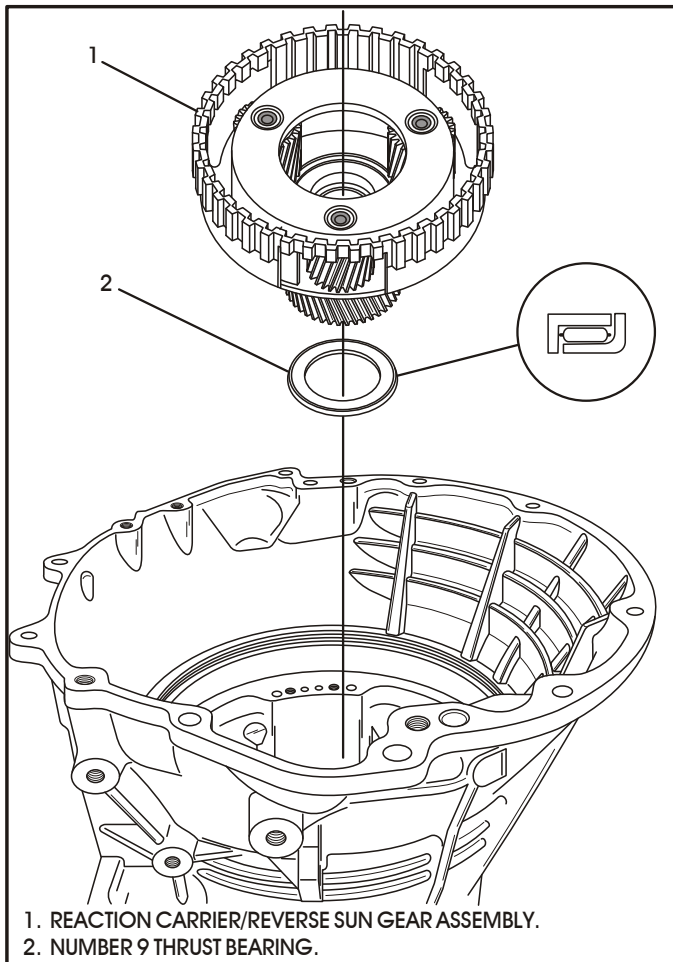

Figure 115

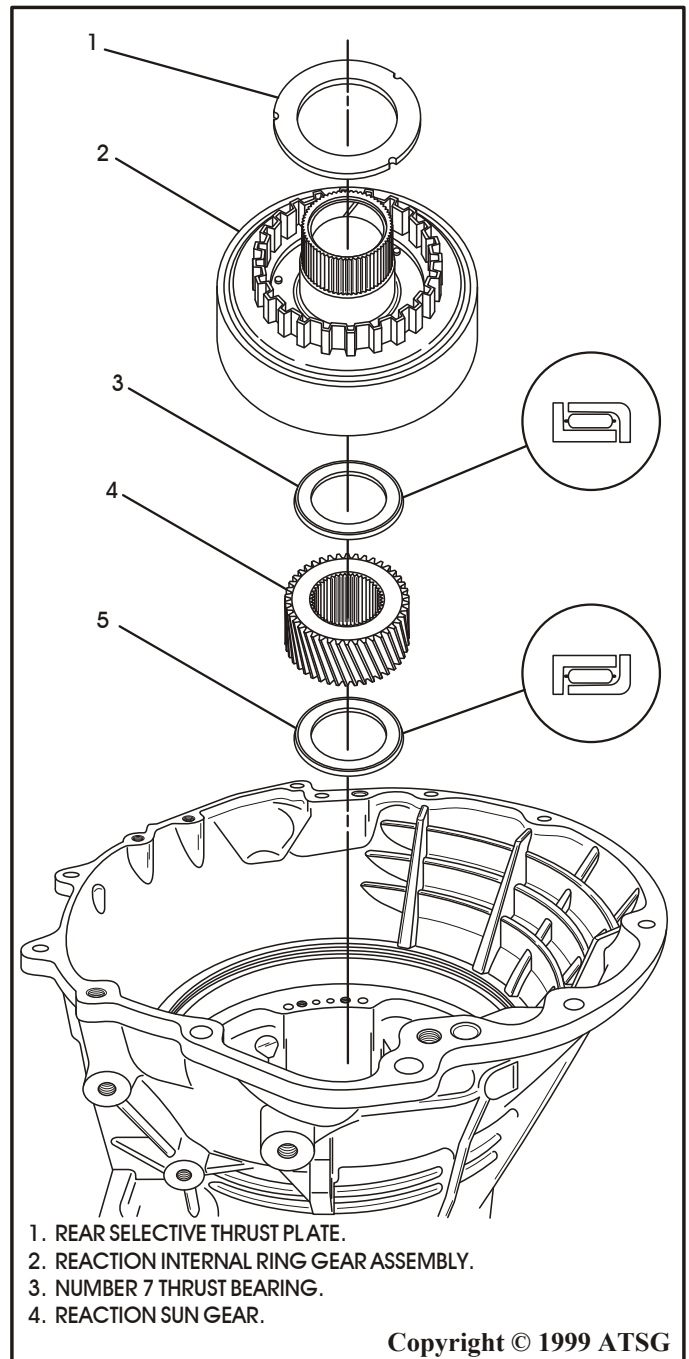

Figure 116

33. Install the number six thrust bearing assembly onto the bottom of 2-4 clutch retainer in the direction shown in Figure 118, and retain with a small amount of TransJel®.
34. Install the 2-4 clutch retainer into the case as shown in Figure 118.
35. Install the 2-4 clutch retainer *tapered* snap ring in case with taper facing up (See Figure 118). Ensure snap ring openings face valve body.

Continued on Page 88.

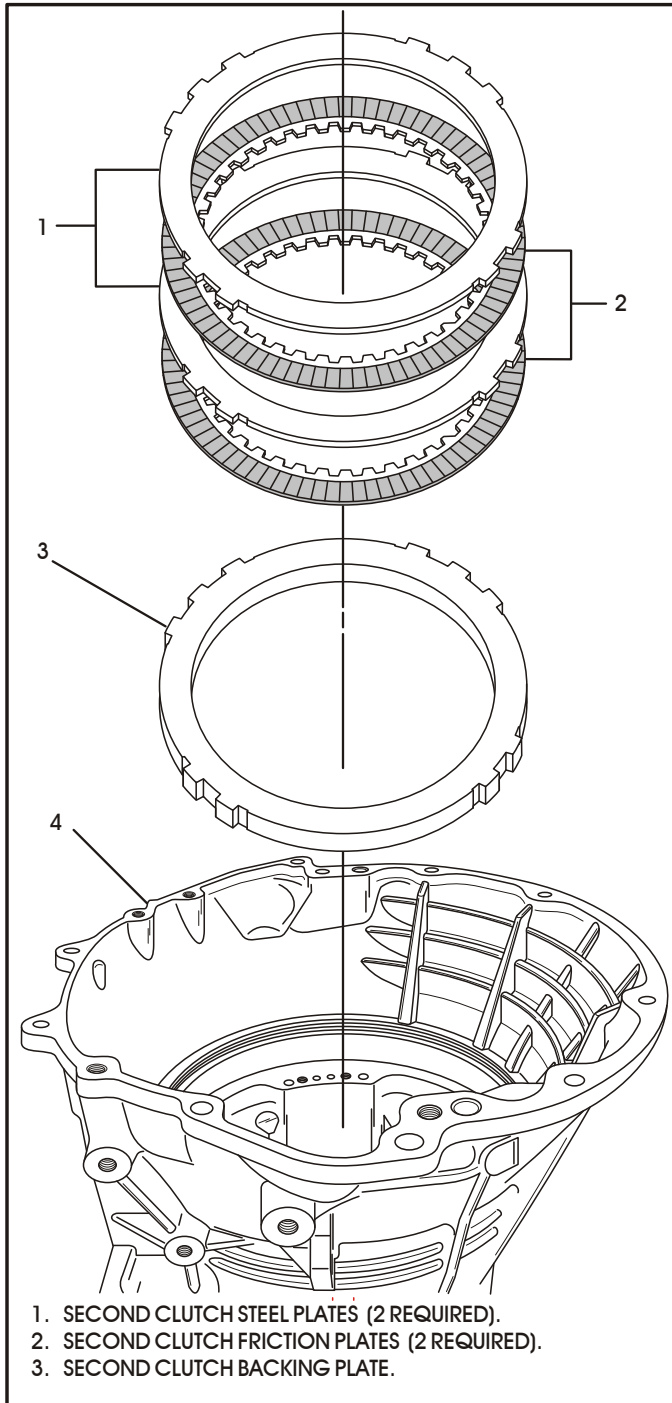

Figure 117

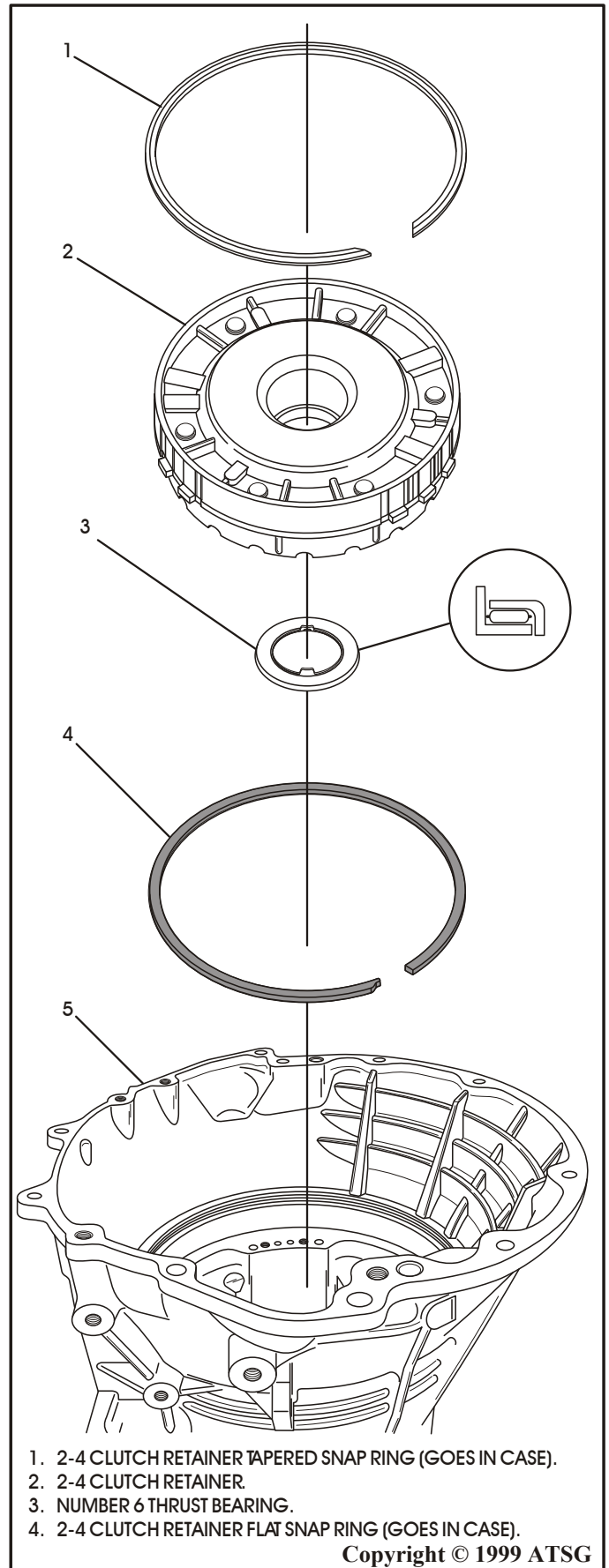

Figure 118

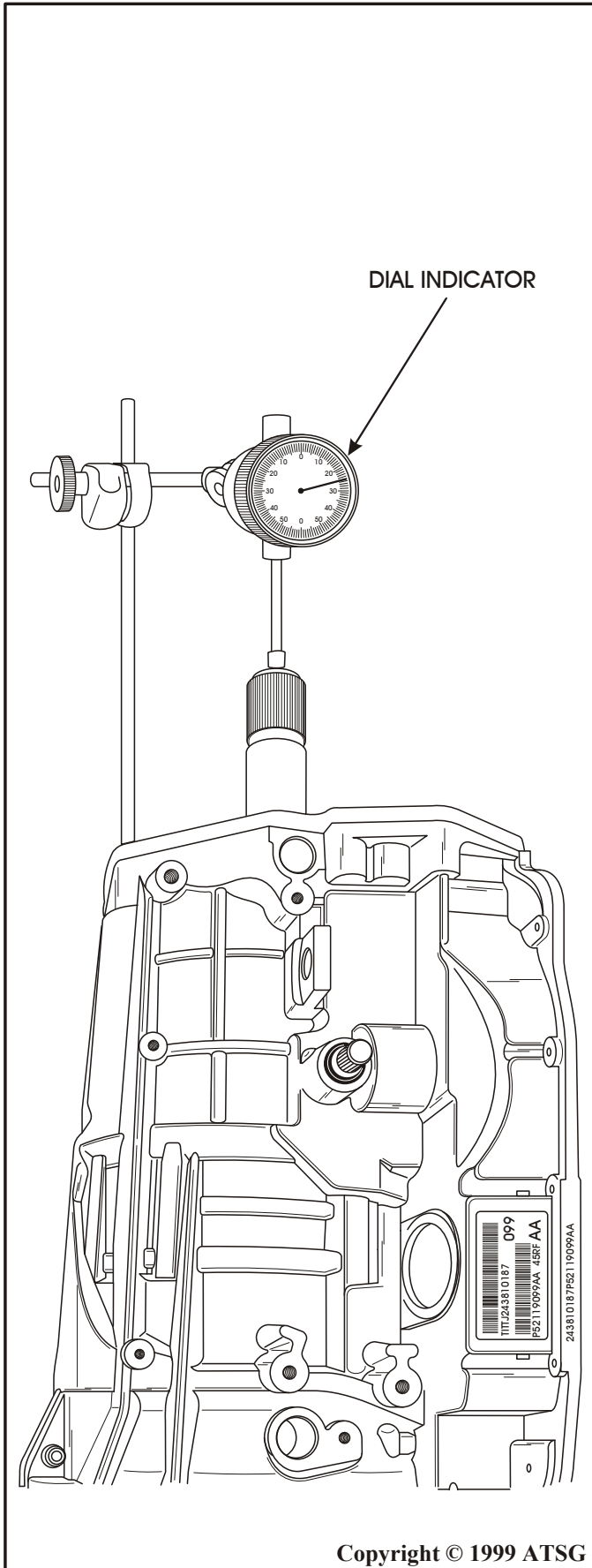

Figure 119

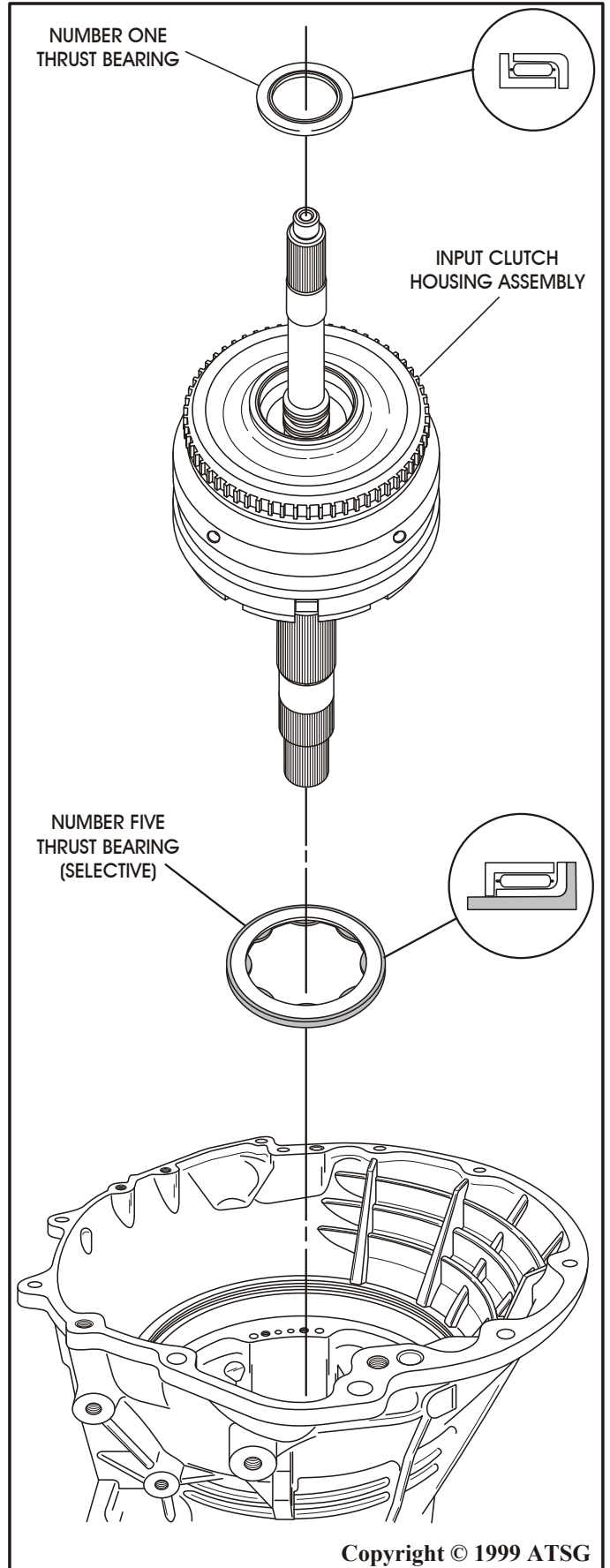

Figure 120

FINAL TRANSMISSION ASSEMBLY (Cont'd)

36. Install dial indicator on case and output shaft as shown in Figure 119. Zero the dial indicator and measure output shaft end play.
37. The correct transmission output shaft end-play should be 0.53-0.78 mm (.021"-.031").
38. Change the rear selective thrust plate that is shown in Figure 116 as necessary to achieve the correct end-play and re-measure to verify.
39. Air check both 2nd clutch and 4th clutch for proper operation.
40. Install the number 5 selective thrust bearing on reverse clutch hub as shown in Figure 120, and retain with a small amount of TransJel®.
41. Install the number 1 thrust bearing assembly with the flat side down, into the pocket of the input housing as shown in Figure 120.

42. Install input clutch housing assembly into the transmission case (See Figure 120). Ensure that input clutch assembly is fully seated by looking through the input speed sensor hole.
43. Install the pre-assembled pump assembly into the transmission case, as shown in Figure 121, and torque the six bolts to 28 Nm (250 in lbs).
44. Install dial indicator and measure input shaft end clearance as shown in Figure 122. Correct end-play is 0.79-1.07 mm (.031"-.042").
45. Change the number 5 selective thrust bearing assembly and re-measure to verify selection.

NOTE: When measuring the input shaft end-play, two "stops" will be felt. When the input shaft is pushed inward and the indicator zeroed, the first stop felt when the input shaft is pulled outward is the movement of the input shaft in the input clutch hub. This value should not be included in the end-play measurement and therefore must be recorded and subtracted from the total dial indicator reading.

Continued on Page 90.

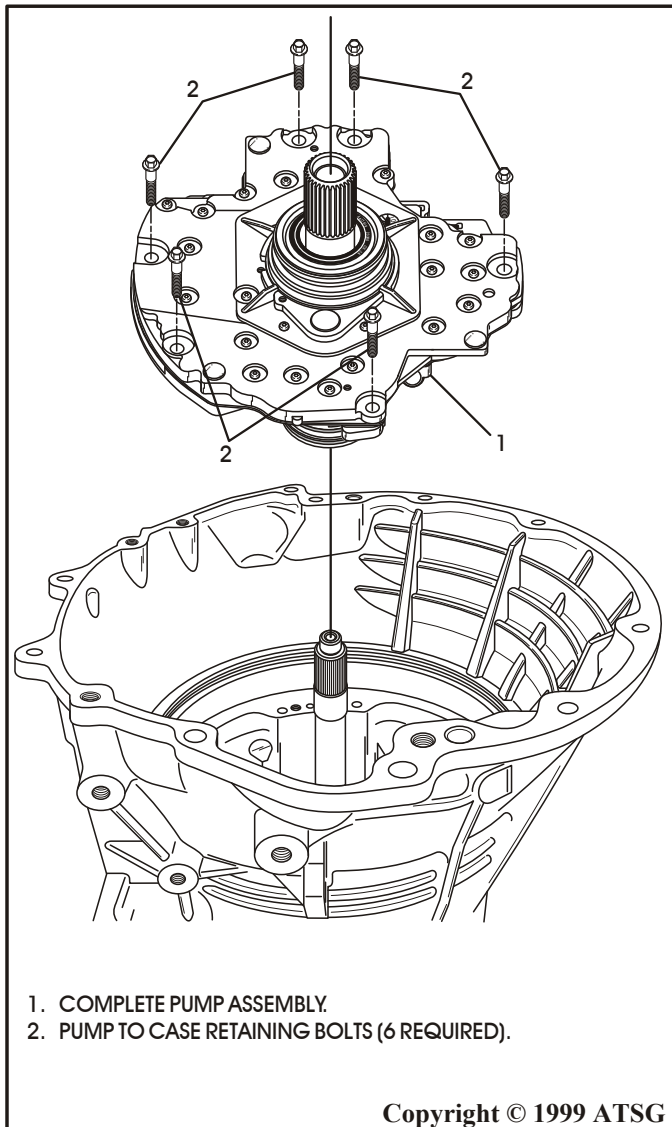

Figure 121

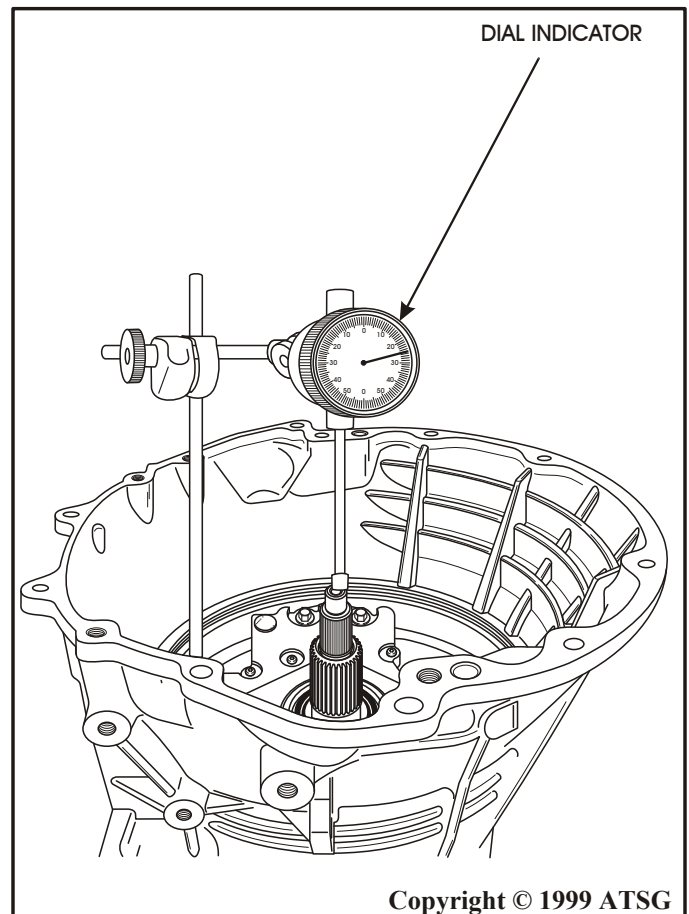

Figure 122

FINAL TRANSMISSION ASSEMBLY (Cont'd)

46. Install the transmission front cover plate which is stamped aluminum with molded inner and outer seals as shown in Figure 123.
47. Install the outer front cover plate snap ring to hold the front cover plate in the case as shown in Figure 123.
48. Install the inner front cover plate snap ring onto the oil pump assembly (See Figure 123).

49. Install the cooler filter by-pass valve into the trans case and torque to 11.3 Nm (100 in lb).
Do Not over-torque! Refer to Figure 124.
50. Install cooler filter in transmission case using a filter wrench (See Figure 124).
51. Air pressure test all clutch components again at this time before valve body is installed using Figure 125 as a guide.

Continued on Page 92.

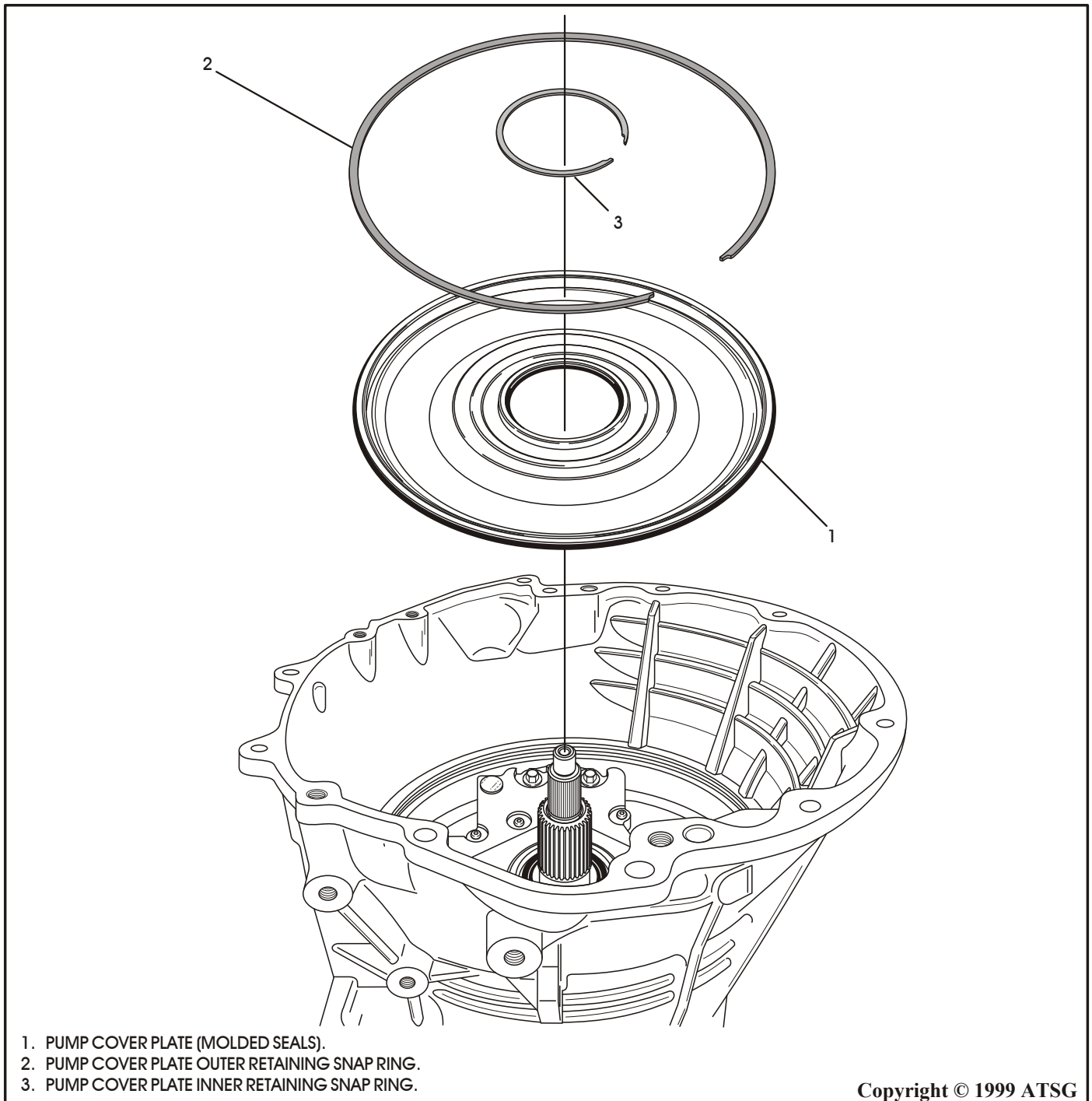

Copyright © 1999 ATSG

Figure 123

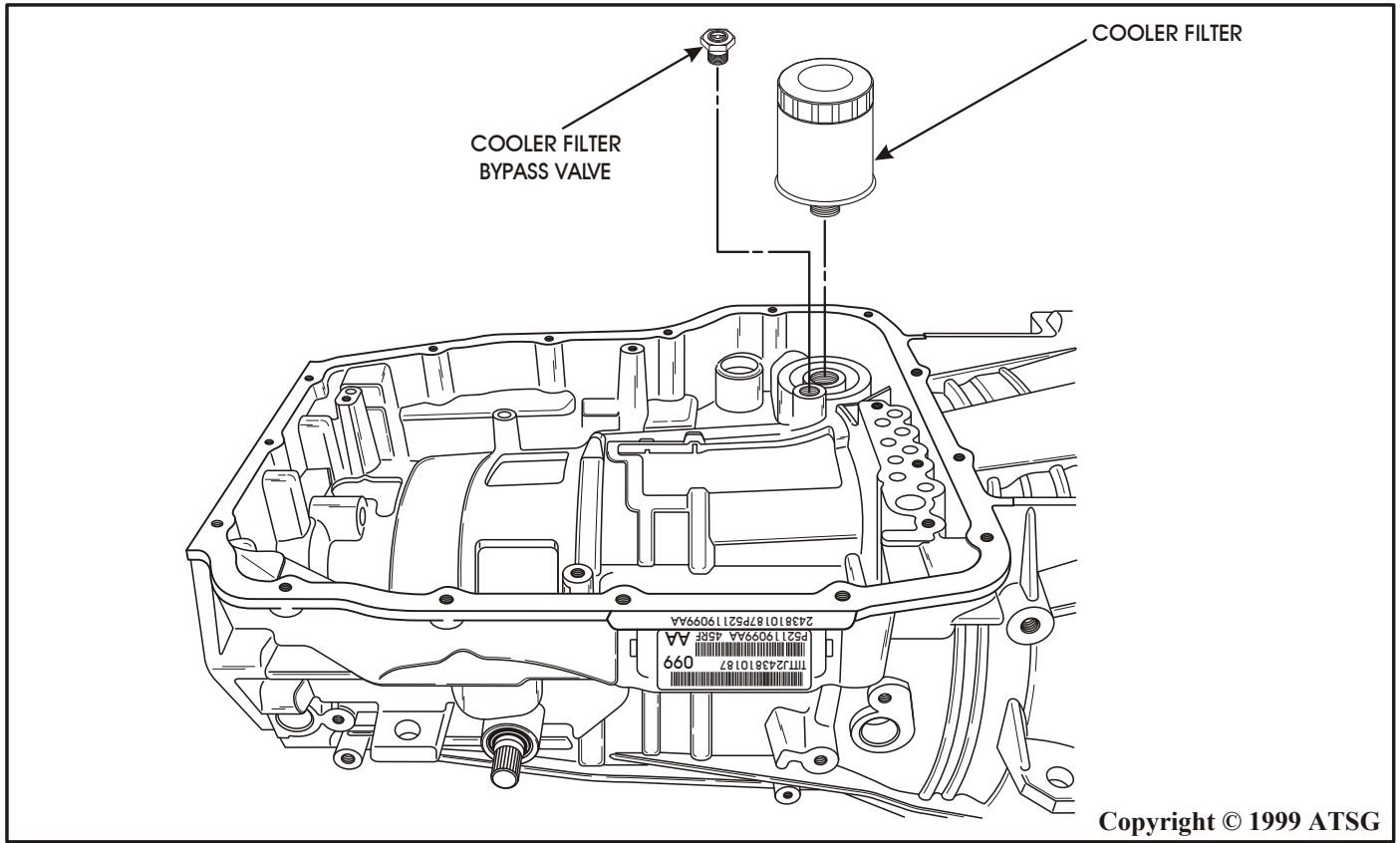

Figure 124

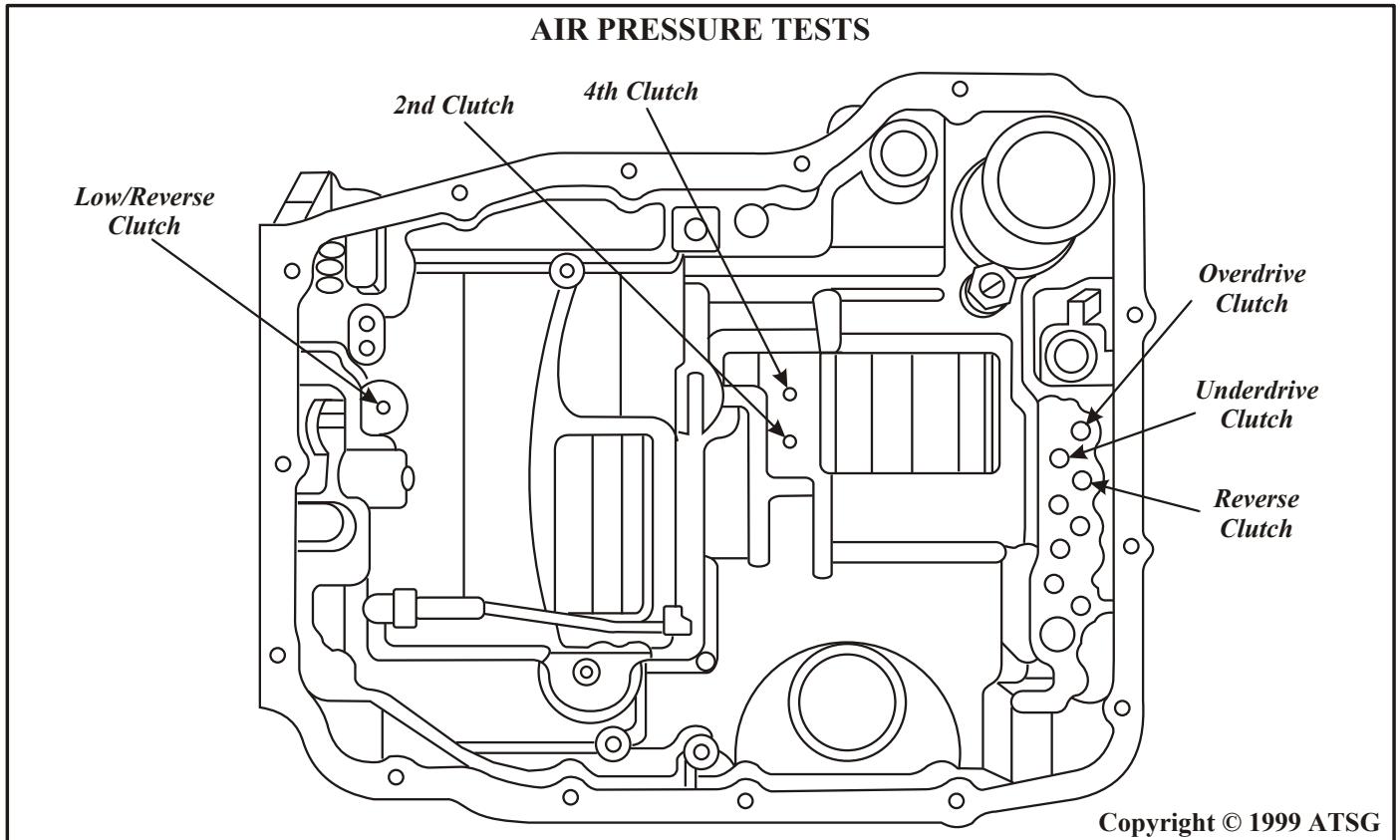

Figure 125

FINAL TRANSMISSION ASSEMBLY (Cont'd)

52. Install the pre-assembled valve body assembly as shown in Figure 126, using the 6 valve body to case bolts. Torque the valve body to case bolts to 12 Nm (105 in lb).
53. Use care when installing the valve body as the assembly has locating dowels that must line up with bores in case, and the 23 way connector seal must not be damaged.
54. Use the illustration in Figure 127 to identify the exact location of the valve body bolts.
55. Install a new primary bottom pan oil filter as shown in Figure 128.
56. Lubricate the oil filter seal before installing so as not to damage it as you install filter into the oil pump filter seal bore.
57. Torque the oil filter bolt to 4.5 Nm (40 in lb).

Continued on Page 94.

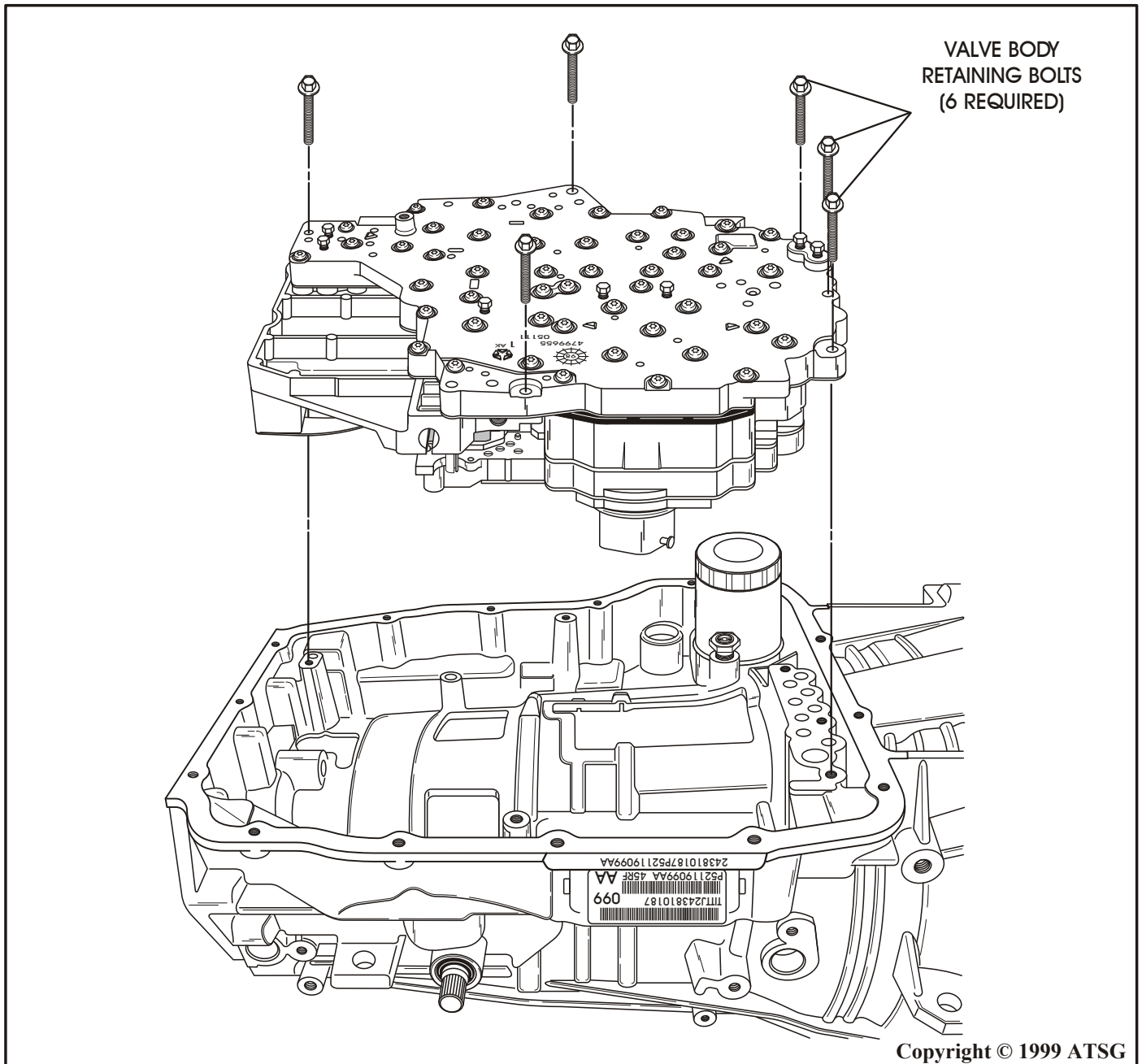

Figure 126

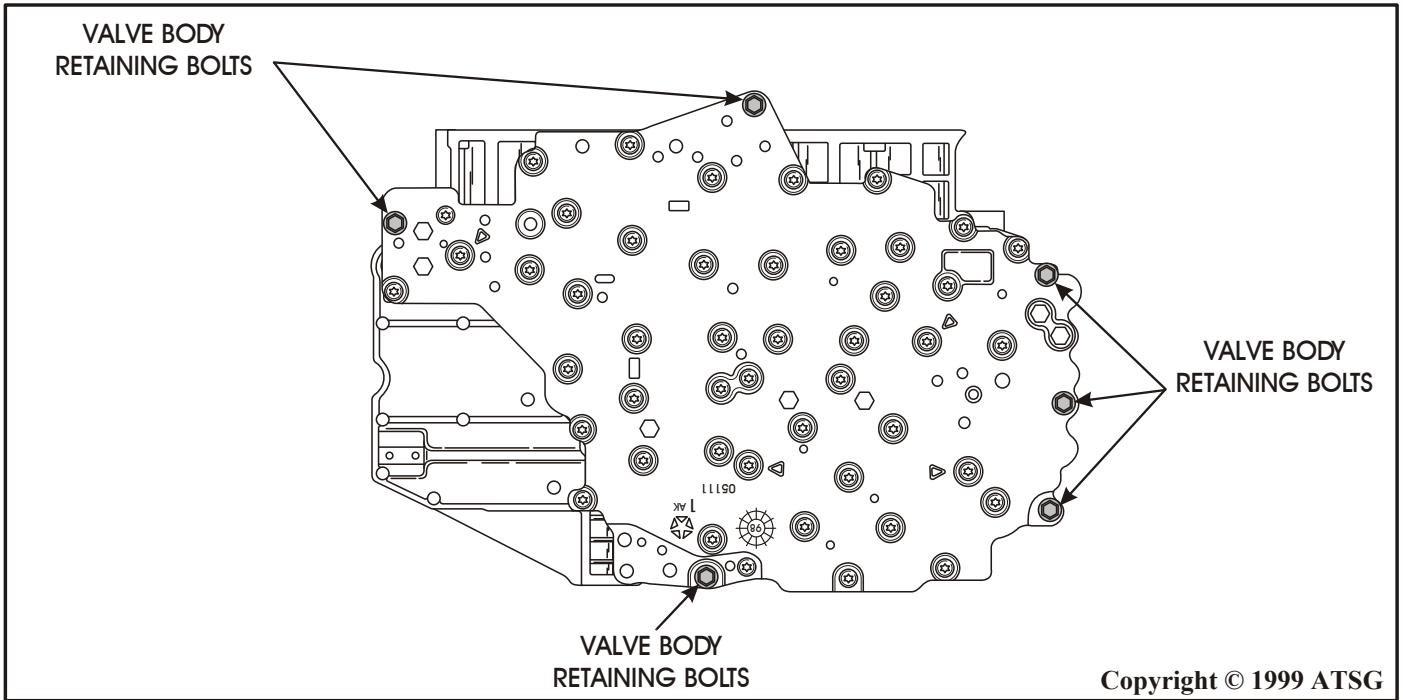

Figure 127

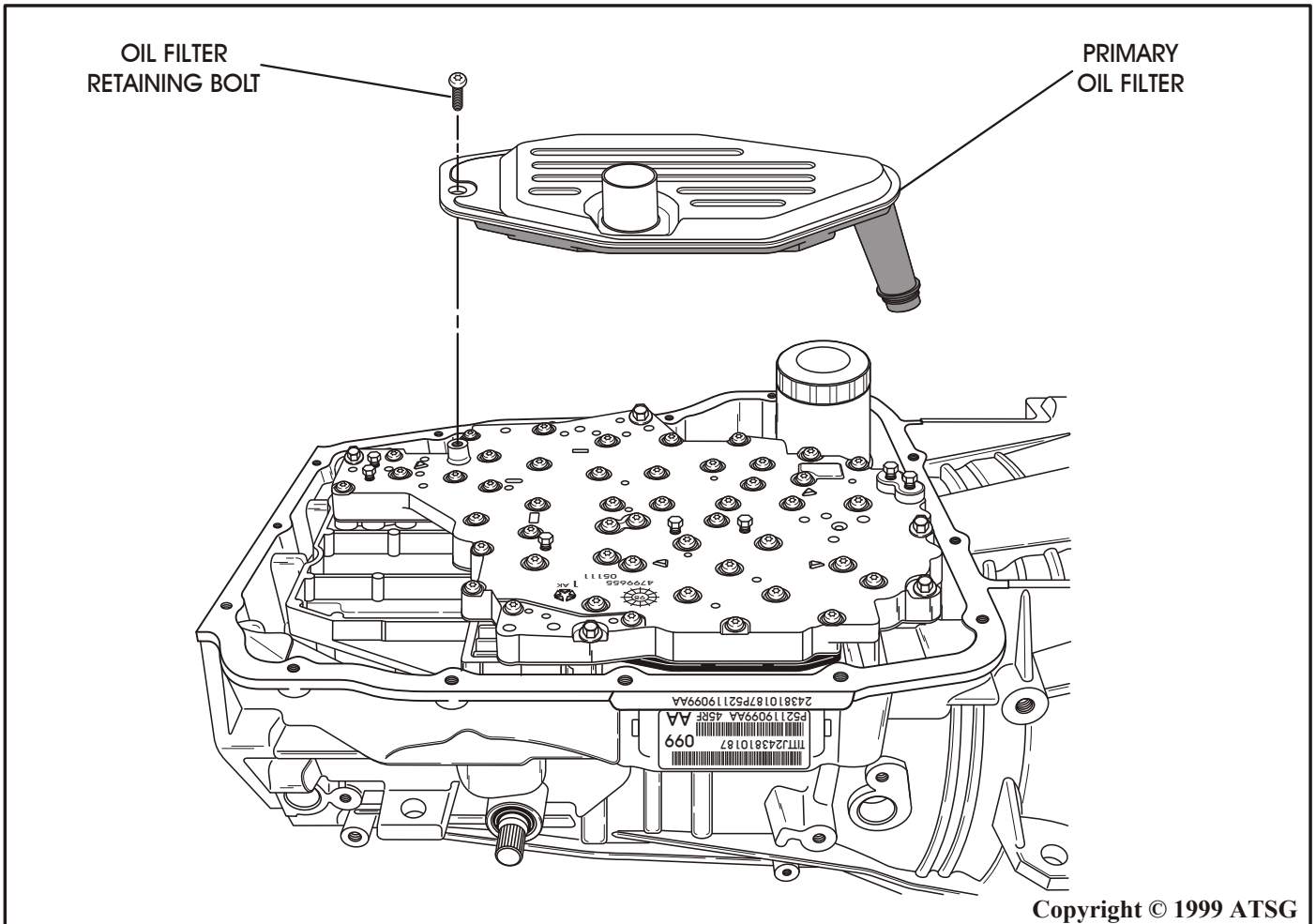
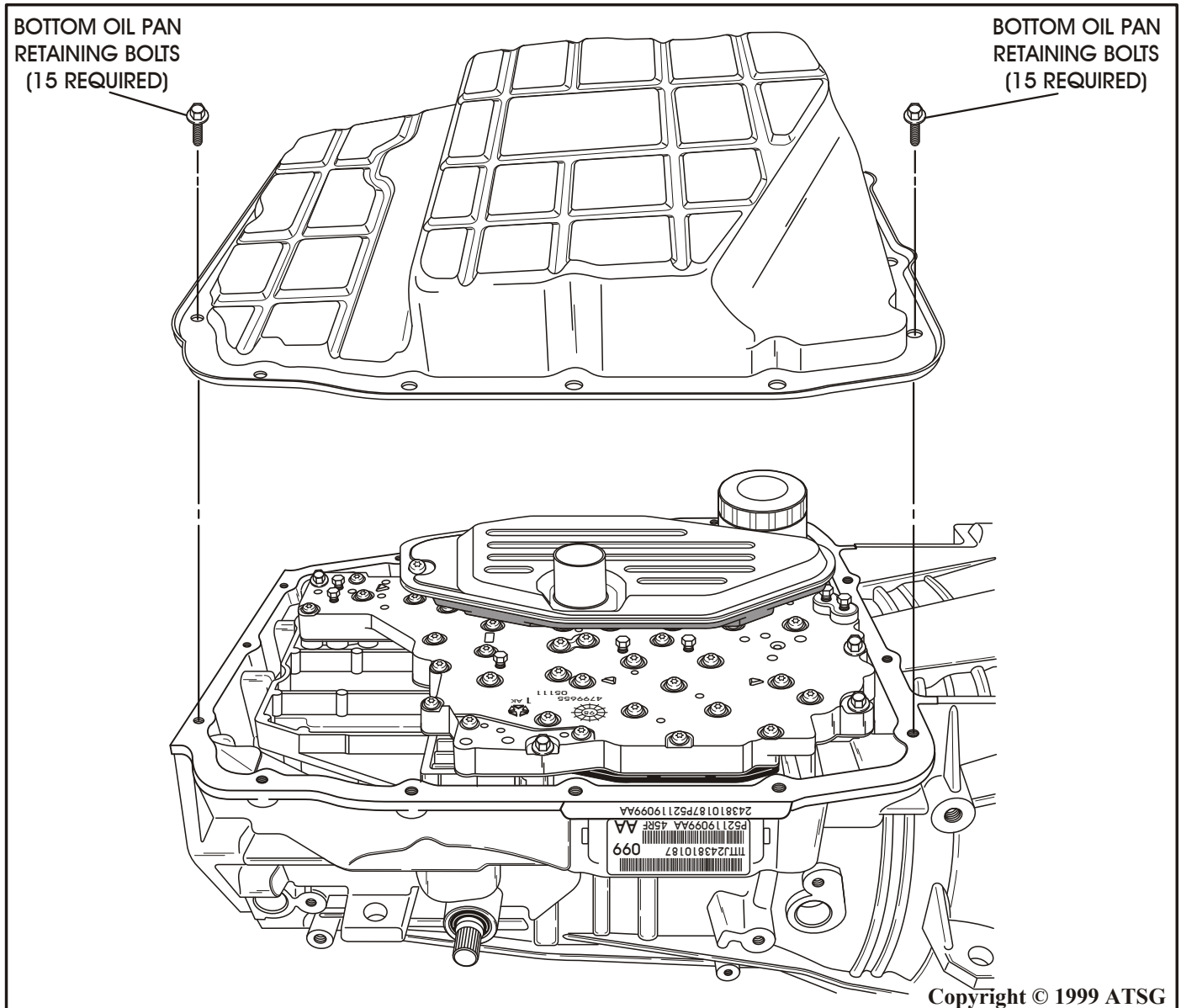

Figure 128

FINAL TRANSMISSION ASSEMBLY (Cont'd)

58. Apply a bead of RTV silicone to the bottom pan and install bottom pan on the transmission case, as shown in Figure 129.
59. Ensure that magnet is inside the oil pan before installation.
60. Install 15 bottom pan retaining bolts, as shown in Figure 129 and torque the pan bolts down to 12 Nm (105 in lb).
61. Turn transmission over on pan and install park gear and park gear retaining snap ring as shown in Figure 130.
62. Apply a bead of RTV silicone and install the extension housing onto the transmission case as shown in Figure 130.
63. Install 12 extension housing bolts/studs and, as shown in Figure 130, and torque bolts down to 54 Nm (40 ft lb).
64. Install input shaft speed sensor into case bore, as shown in Figure 131, and torque bolt down to 12 Nm (105 in lb).
65. Install output shaft speed sensor into case bore, as shown in Figure 131, and torque bolt down to 12 Nm (105 in lb).

Continued on Page 96.



Copyright © 1999 ATSG

Figure 129

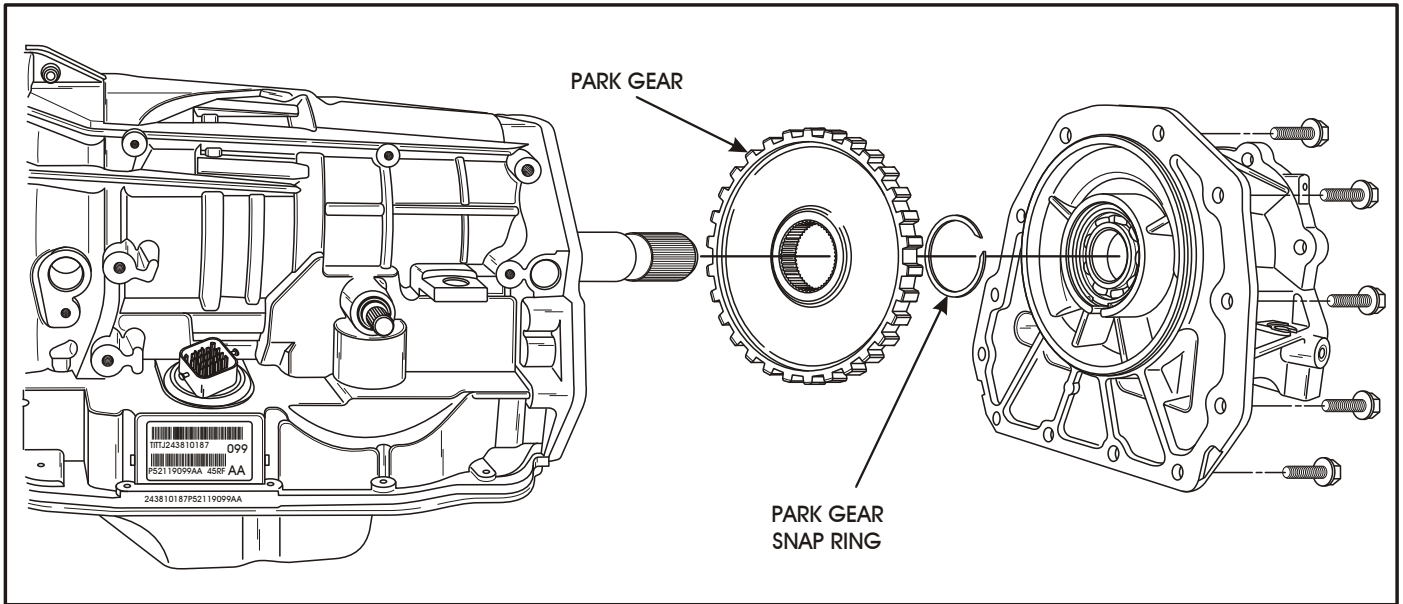

Figure 130

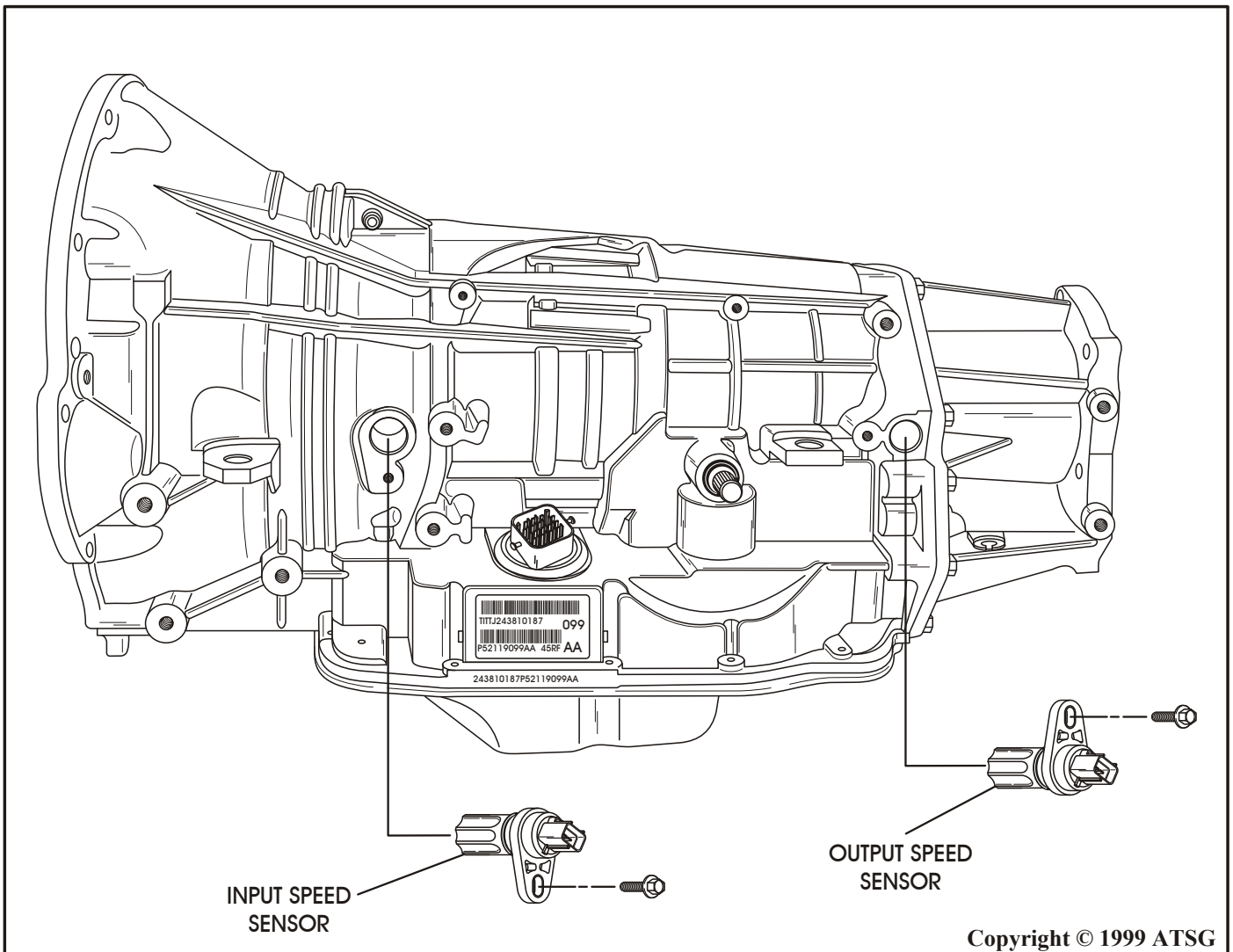

Figure 131

Copyright © 1999 ATSG

FINAL TRANSMISSION ASSEMBLY (Cont'd)

66. Install a new dipstick tube seal into the case bore as shown in Figure 132.
67. Install line pressure sensor into case bore, as shown in Figure 132, and torque bolt down to 12 Nm (105 in lbs).
68. If removed, install and torque both cooler line fittings in case to 17.5 Nm (155 in lbs).
69. This concludes transmission final assembly.

END-PLAY SPECIFICATIONS

Output Shaft End-Play	0.53-0.78 mm (.021"-.031")
Input Shaft End-Play	0.79-1.07 mm (.031"-.042")
2nd Clutch Clearance	0.53-1.27 mm (.021"-.050")
4th Clutch Clearance	0.81-1.35 mm (.032"-.053")
L/R Clutch Clearance	1.14-1.91 mm (.045"-.075")
OD Clutch Clearance	1.01-1.65 mm (.040"-.065")
UD Clutch Clearance	0.76-1.60 mm (.030"-.063")

ONLY RECOMMENDED FLUID

Mopar® ATF Plus 3, Type 7176

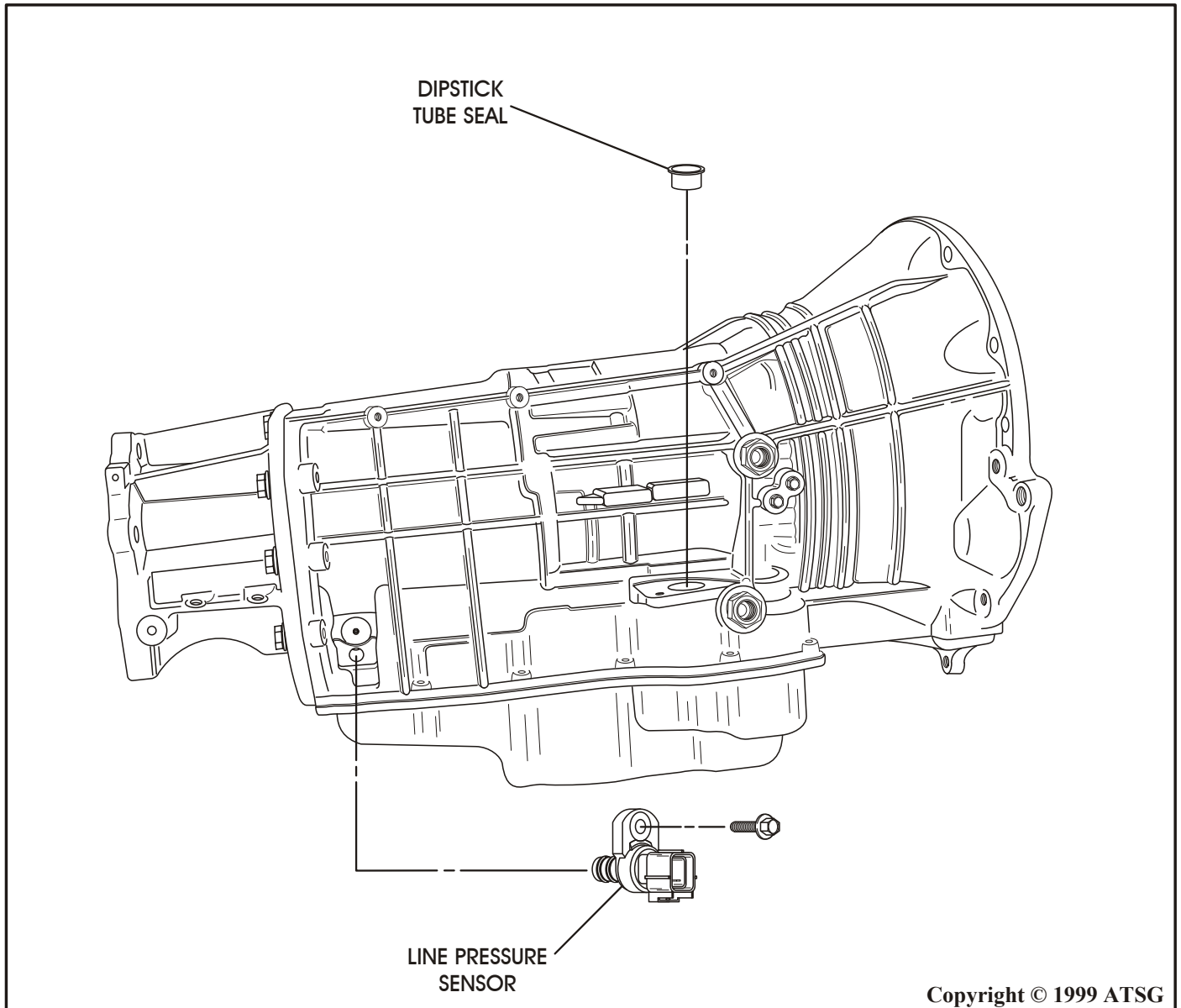

Copyright © 1999 ATSG

Figure 129

TORQUE SPECIFICATIONS

Cooler Line Fittings	17.5 Nm (155 in lbs)
Bottom Oil Pan Bolts	11.8 Nm (105 in lbs)
Main Oil Filter Screw	4.5 Nm (40 in lbs)
Cooler Return Filter	14 Nm (125 in lbs)
Oil Pump Assembly Bolts	28.2 Nm (250 in lbs)
Oil Pump Body To Oil Pump Cover Screws	4.5 Nm (40 in lbs)
Oil Pump Spacer Plate To Pump Body Screws	4.5 Nm (40 in lbs)
Pressure Test Port Plugs	5.1 Nm (45 in lbs)
Stator Support To Pump Body Screws	11.8 Nm (105 in lbs)
Transfer Plate to Valve Body Screws	4.5 Nm (40 in lbs)
TRS/Solenoid Pack To Transfer Plate Screws	5.7 Nm (50 in lbs)
Accumulator Cover To Valve Body Screws	4.5 Nm (40 in lbs)
Detent Spring Retaining Screw	4.5 Nm (40 in lbs)
Input Speed Sensor Bolt	11.8 Nm (105 in lbs)
Output Speed Sensor Bolt	11.8 Nm (105 in lbs)
Line Pressure Sensor Bolt	11.8 Nm (105 in lbs)
Extension Housing Bolts	54 Nm (40 ft lbs)
TRS Selector Plate To Valve Body Screw	4.5 Nm (40 in lbs)

Figure 130

BOLT IDENTIFICATION

Bolts Drawn Actual Size

- A. SOLENOID BODY GASKET TO SOLENOID BODY (2 REQUIRED).
- B. TRS SELECTOR PLATE TO VALVE BODY (1 REQUIRED).
- C. ACCUMULATOR COVER TO VALVE BODY (7 REQUIRED).
- C. PUMP SPACER PLATE TO PUMP BODY (2 REQUIRED).
- D. OIL PUMP BODY TO OIL PUMP COVER (24 REQUIRED).
- E. TRANSFER PLATE TO VALVE BODY, SILVER COLOR (50 REQUIRED).
- E. TRS/SOLENOID PACK COVER BOLTS, GOLD COLOR (6 REQUIRED).
- F. STATOR SUPPORT TO PUMP BODY (5 REQUIRED).
- G. OIL PAN TO TRANSMISSION CASE (15 REQUIRED).
- H. INPUT, OUTPUT, LINE PRESSURE SENSORS TO CASE (3 REQUIRED).
- J. VALVE BODY TO TRANSMISSION CASE (6 REQUIRED).
- K. OIL PUMP TO TRANSMISSION CASE (6 REQUIRED).
- L. EXTENSION HOUSING TO TRANSMISSION CASE (10 REQUIRED).
- M. EXTENSION HOUSING TO TRANSMISSION CASE (2 REQUIRED).
- N. MANUAL SHAFT RETAINING BOLT (1 REQUIRED).

Figure 131

OIL PUMP ASSEMBLY EXPLODED VIEW

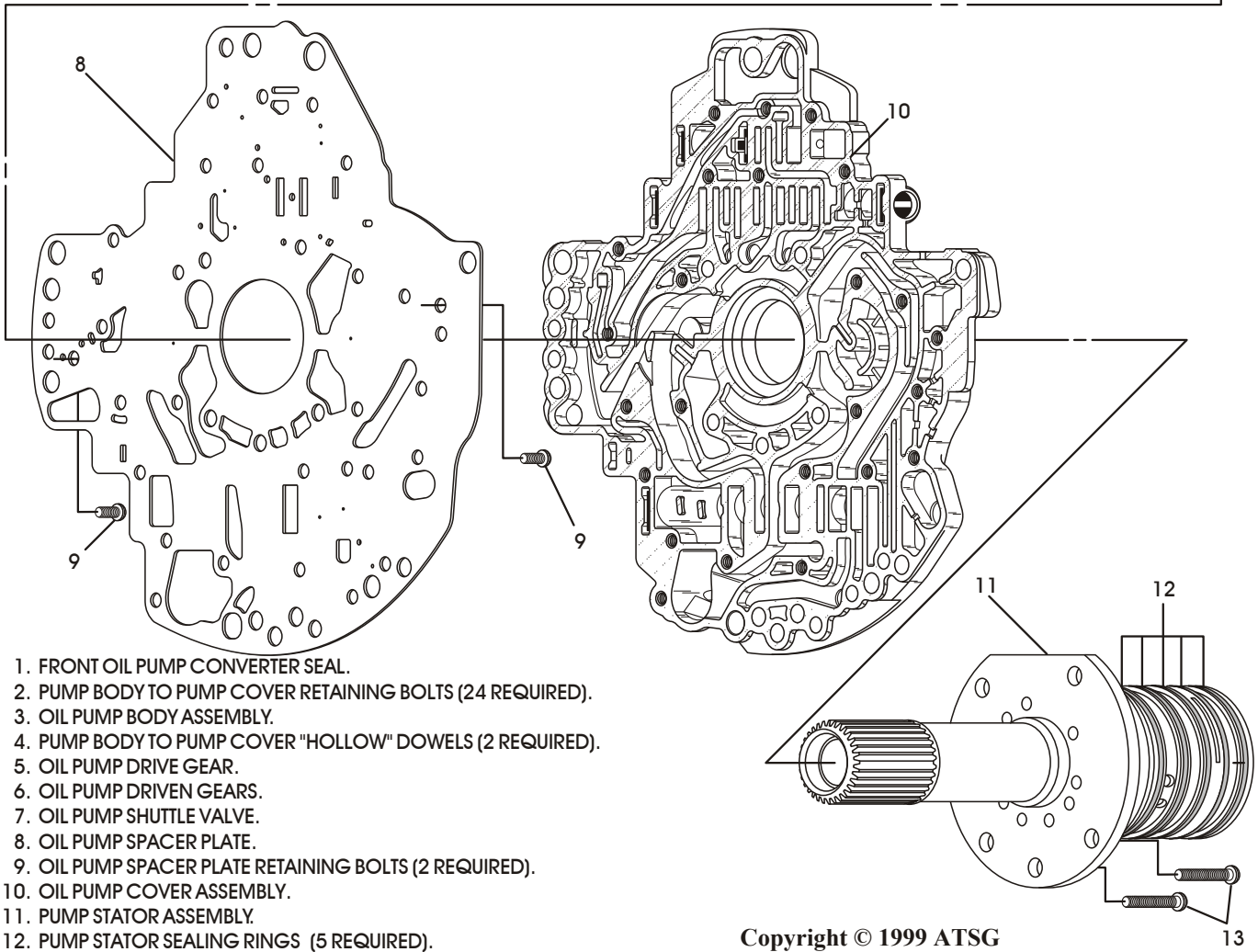
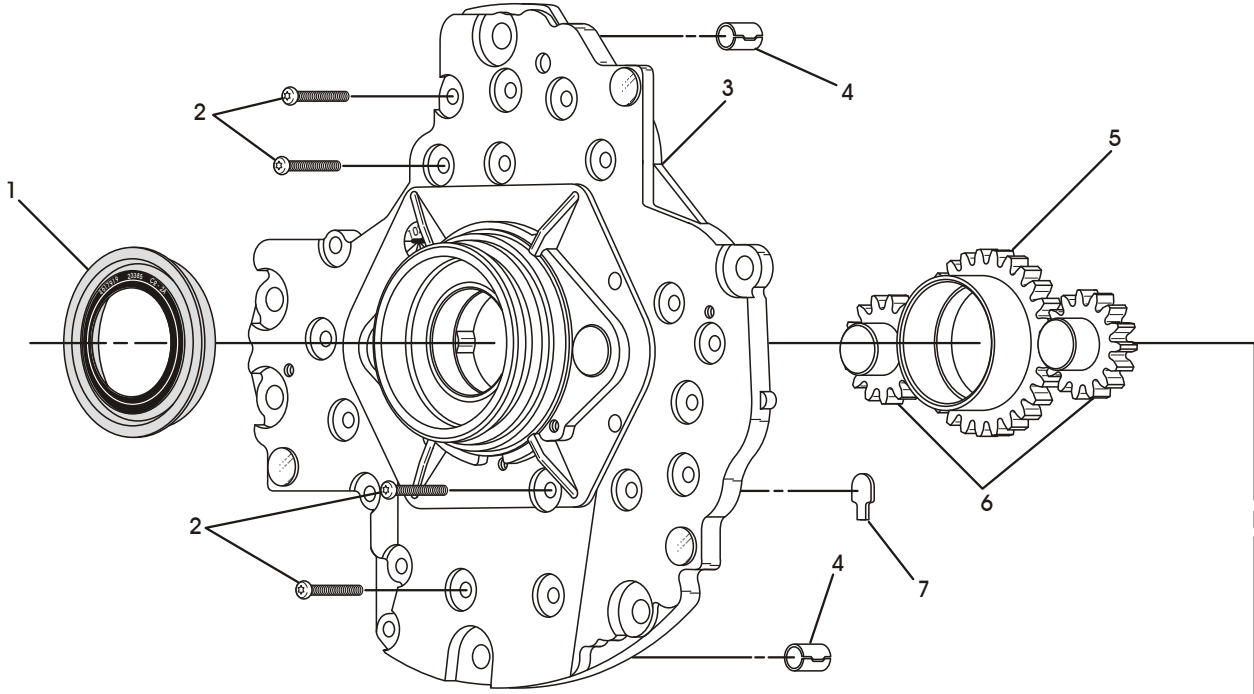

1. FRONT OIL PUMP CONVERTER SEAL.
2. PUMP BODY TO PUMP COVER RETAINING BOLTS (24 REQUIRED).
3. OIL PUMP BODY ASSEMBLY.
4. PUMP BODY TO PUMP COVER "HOLLOW" DOWELS (2 REQUIRED).
5. OIL PUMP DRIVE GEAR.
6. OIL PUMP DRIVEN GEARS.
7. OIL PUMP SHUTTLE VALVE.
8. OIL PUMP SPACER PLATE.
9. OIL PUMP SPACER PLATE RETAINING BOLTS (2 REQUIRED).
10. OIL PUMP COVER ASSEMBLY.
11. PUMP STATOR ASSEMBLY.
12. PUMP STATOR SEALING RINGS (5 REQUIRED).

Copyright © 1999 ATSG

13

Figure 132

GEAR TRAIN COMPONENTS EXPLODED VIEW

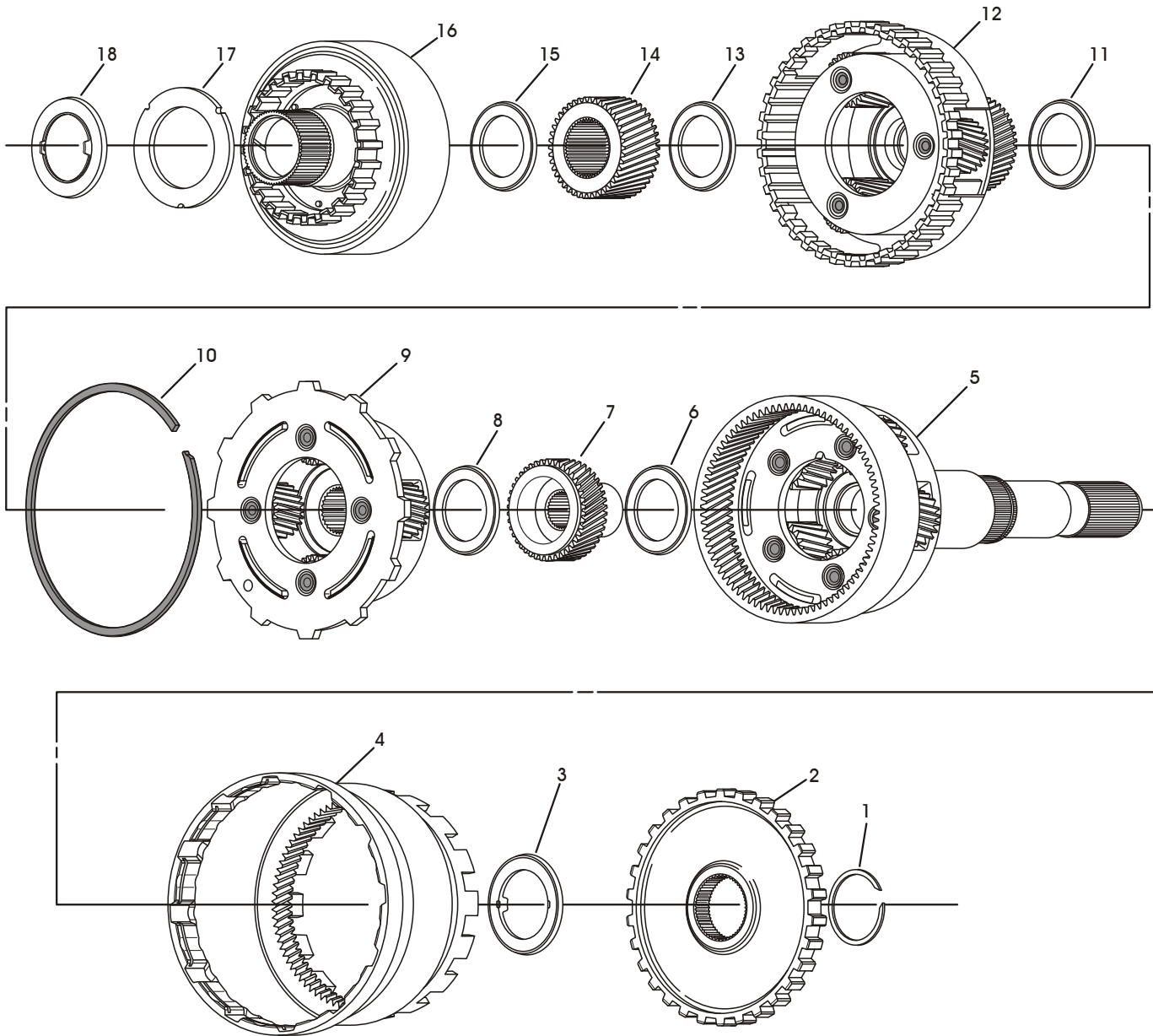

- | | |
|---|---|
| <ul style="list-style-type: none"> 1. PARK GEAR RETAINING SNAP RING. 2. PARK GEAR ASSEMBLY. 3. NUMBER 12 THRUST BEARING. 4. INPUT INTERNAL RING GEAR. 5. INPUT PLANETARY CARRIER/REVERSE INTERNAL RING GEAR. 6. NUMBER 11 THRUST BEARING. 7. INPUT SUN GEAR. 8. NUMBER 10 THRUST BEARING. 9. REVERSE PLANETARY CARRIER ASSEMBLY. | <ul style="list-style-type: none"> 10. REVERSE CARRIER/INPUT RING GEAR "FLAT" SNAP RING. 11. NUMBER 9 THRUST BEARING. 12. REACTION CARRIER/REVERSE SUN GEAR ASSEMBLY. 13. NUMBER 8 THRUST BEARING. 14. REACTION SUN GEAR. 15. NUMBER 7 THRUST BEARING. 16. REACTION INTERNAL RING GEAR ASSEMBLY. 17. SELECTIVE THRUST WASHER PLATE. 18. NUMBER 6 THRUST BEARING. |
|---|---|

Copyright © 1999 ATSG

Figure 133

INPUT CLUTCH HOUSING COMPONENTS EXPLODED VIEW

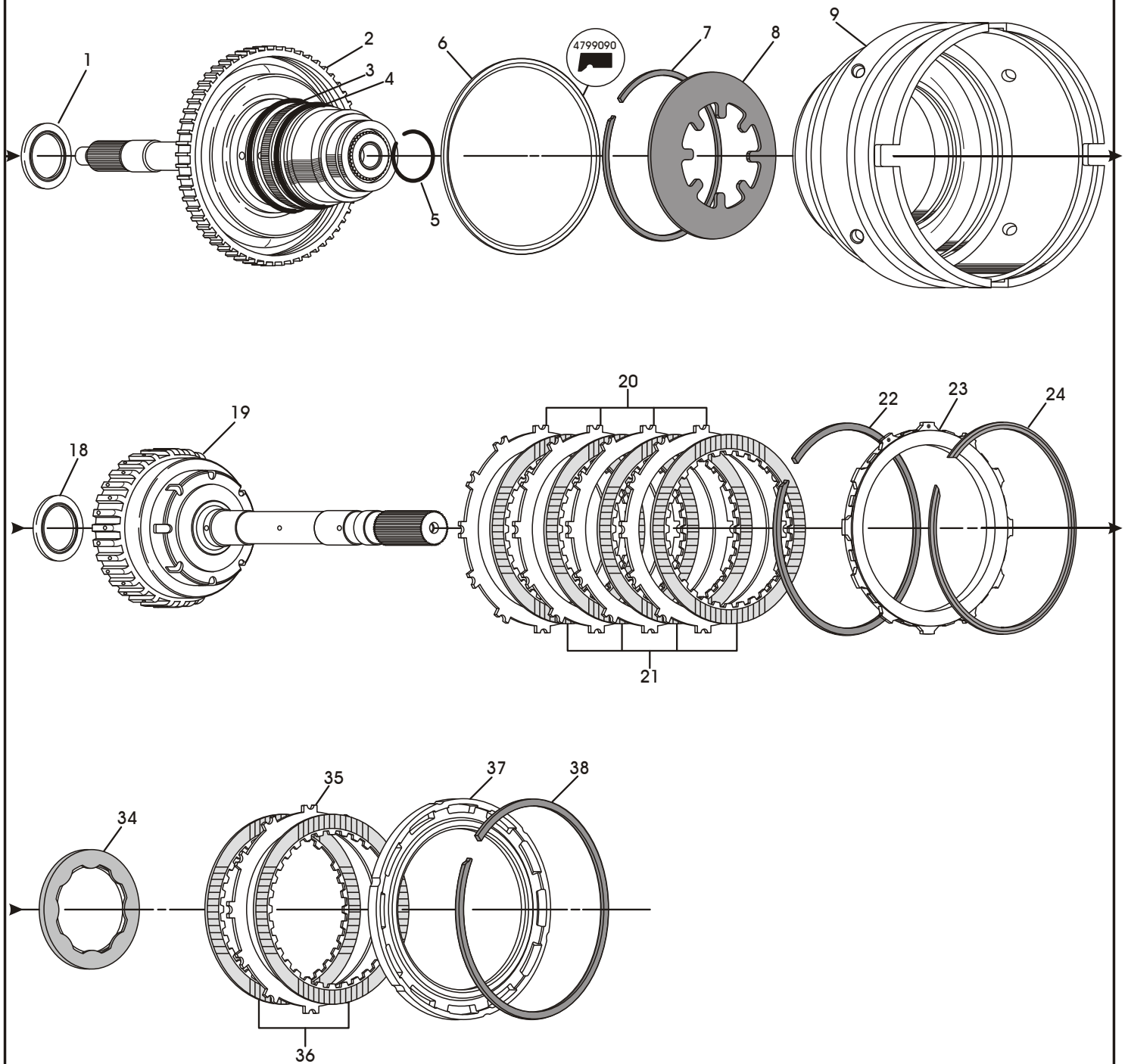

Copyright © 1999 ATSG

Figure 134

INPUT CLUTCH HOUSING COMPONENTS EXPLODED VIEW

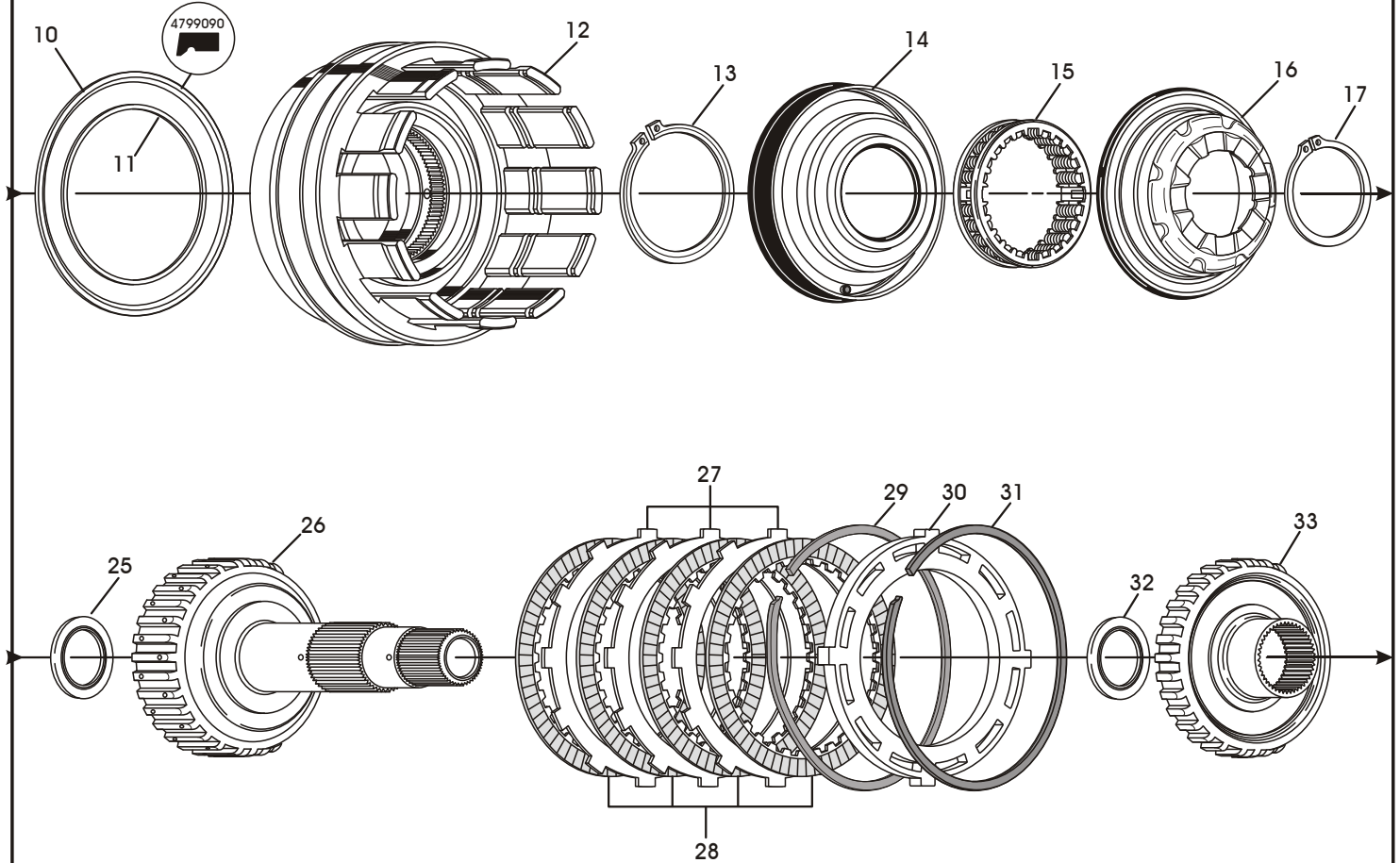

- | | |
|---|--|
| <ol style="list-style-type: none"> 1. NUMBER 1 THRUST BEARING. 2. INPUT CLUTCH HUB. 3. GREEN COLORED "O" RING. 4. RED COLORED "O" RING. 5. INPUT SHAFT RETAINING CIR-CLIP. 6. REVERSE OUTER LIP SEAL (INSIDE LIP). 7. OVERDRIVE/REVERSE PISTON BELLVILLE SNAP RING. 8. OVERDRIVE/REVERSE PISTON BELLVILLE PLATE. 9. OVERDRIVE/REVERSE PISTON ASSEMBLY. 10. OVERDRIVE OUTER LIP SEAL (INSIDE LIP). 11. OVERDRIVE/REVERSE INNER "O" RING. 12. INPUT CLUTCH RETAINER. 13. "BEVELED" SNAP RING (INSIDE BEVEL). 14. UNDERDRIVE CLUTCH PISTON ASSEMBLY. 15. UNDERDRIVE CLUTCH RETURN SPRING ASSEMBLY. 16. SPRING RETAINER AND BALANCE PISTON ASSEMBLY. 17. "FLAT" SNAP RING. 18. NUMBER 2 THRUST BEARING. | <ol style="list-style-type: none"> 20. UNDERDRIVE CLUTCH STEEL PLATES .067" THICK (4 REQUIRED). 21. UNDERDRIVE CLUTCH LINED PLATES .078" THICK (4 REQUIRED). 22. UNDERDRIVE/OVERDRIVE REACTION PLATE "FLAT" SNAP RING. 23. UNDERDRIVE/OVERDRIVE REACTION PLATE. 24. UNDERDRIVE/OD REACTION PLATE "TAPERED" SNAP RING. 25. NUMBER 3 THRUST BEARING. 26. OVERDRIVE CLUTCH HUB AND SHAFT ASSEMBLY. 27. OVERDRIVE CLUTCH STEEL PLATES .086" THICK (3 REQUIRED). 28. OVERDRIVE CLUTCH LINED PLATES .090" THICK (4 REQUIRED). 29. OVERDRIVE/REVERSE REACTION PLATE "WAVE" SNAP RING. 30. OVERDRIVE/REVERSE REACTION PLATE. 31. OVERDRIVE/REVERSE REACTION PLATE "FLAT" SNAP RING. 32. NUMBER 4 THRUST BEARING. 33. REVERSE CLUTCH HUB ASSEMBLY. 34. NUMBER 5 "SELECTIVE" THRUST BEARING ASSEMBLY. 35. REVERSE CLUTCH STEEL PLATE .067" THICK (1 REQUIRED). 36. REVERSE CLUTCH LINED PLATES .080" THICK (2 REQUIRED). 37. REVERSE CLUTCH BACKING PLATE. 38. REVERSE CLUTCH BACKING PLATE "FLAT" SNAP RING. |
|---|--|

Copyright © 1999 ATSG

Figure 135

2-4 CLUTCH RETAINER EXPLODED VIEW

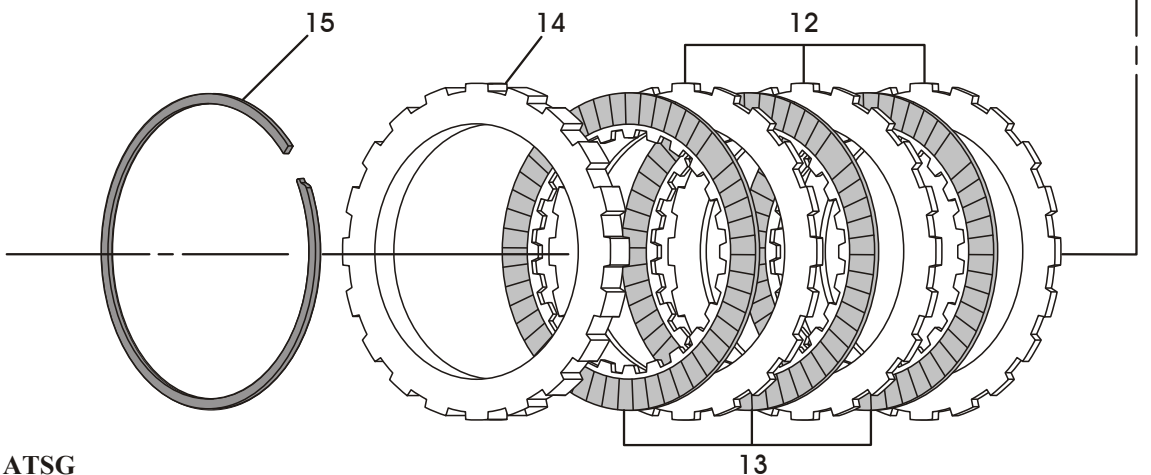
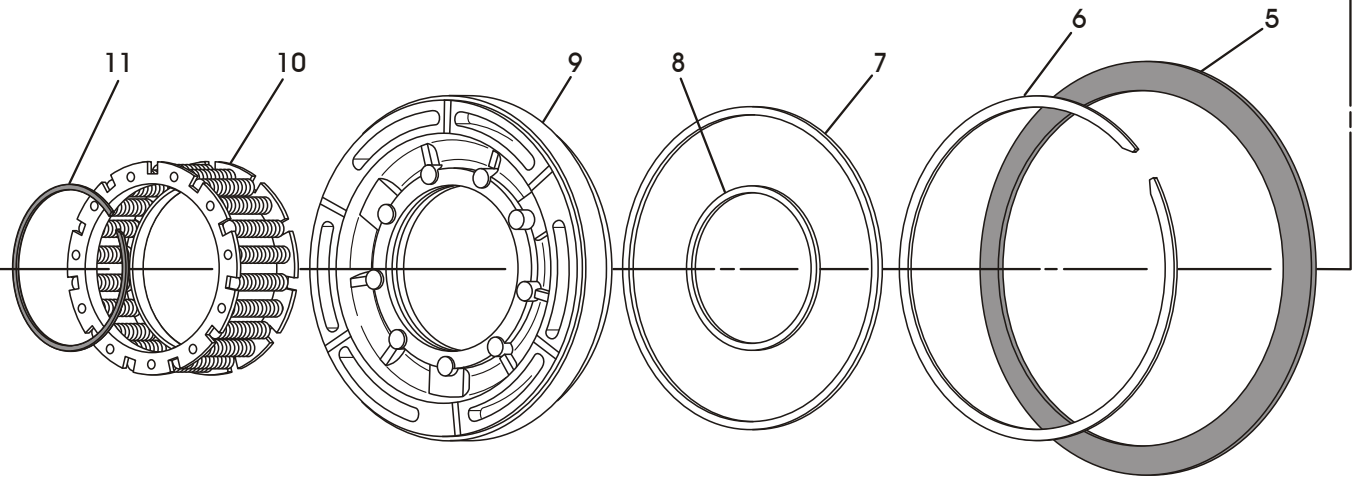
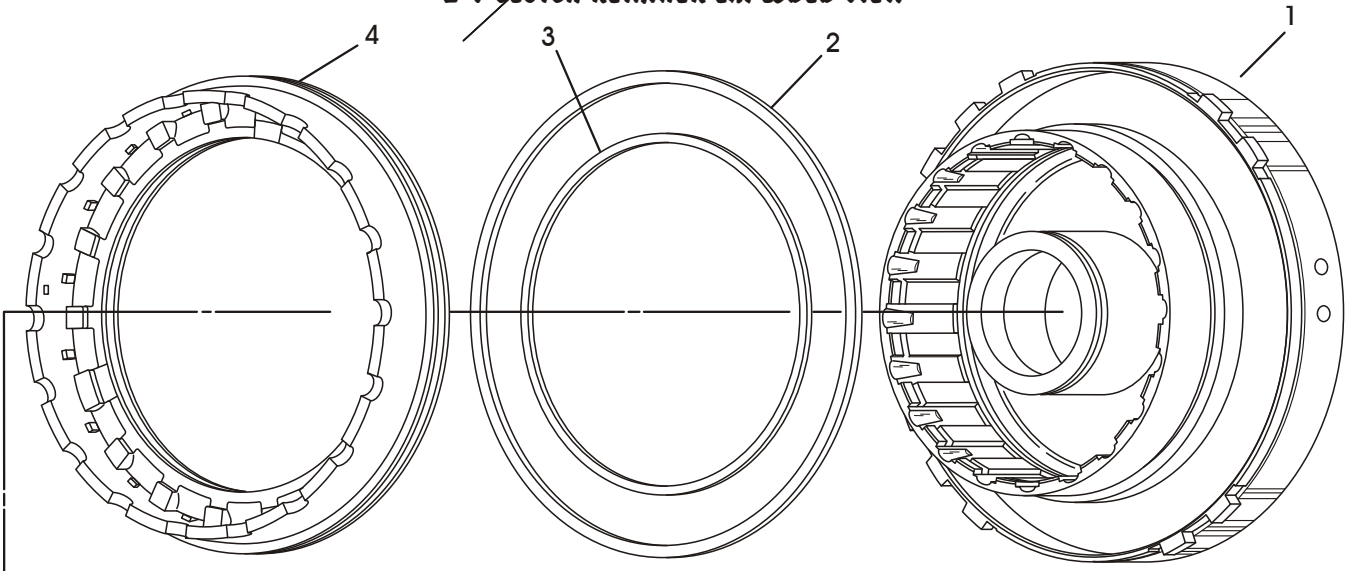

Copyright © 1999 ATSG

Figure 136

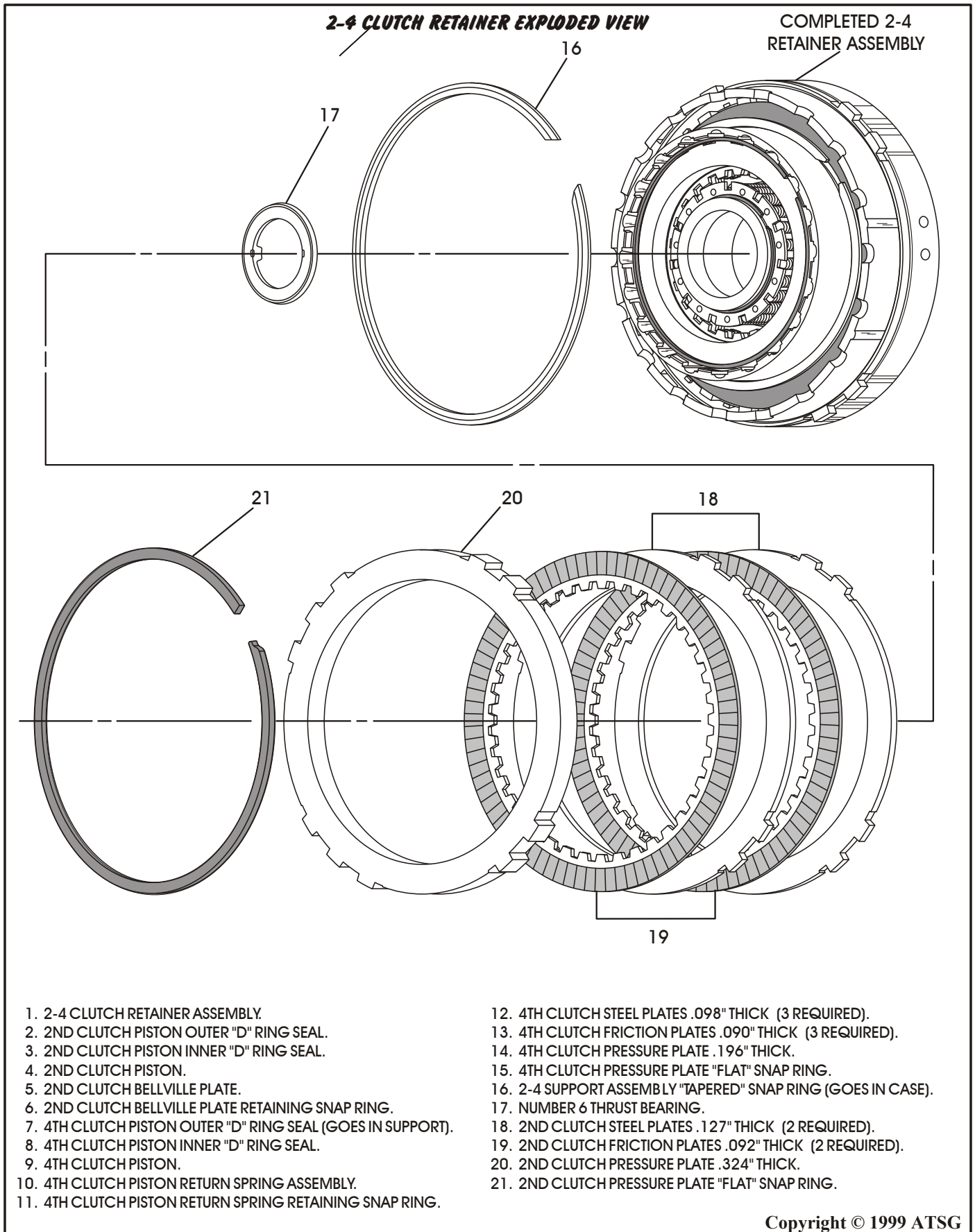

Copyright © 1999 ATSG

Figure 137

LOW/REVERSE CLUTCH HOUSING EXPLODED VIEW

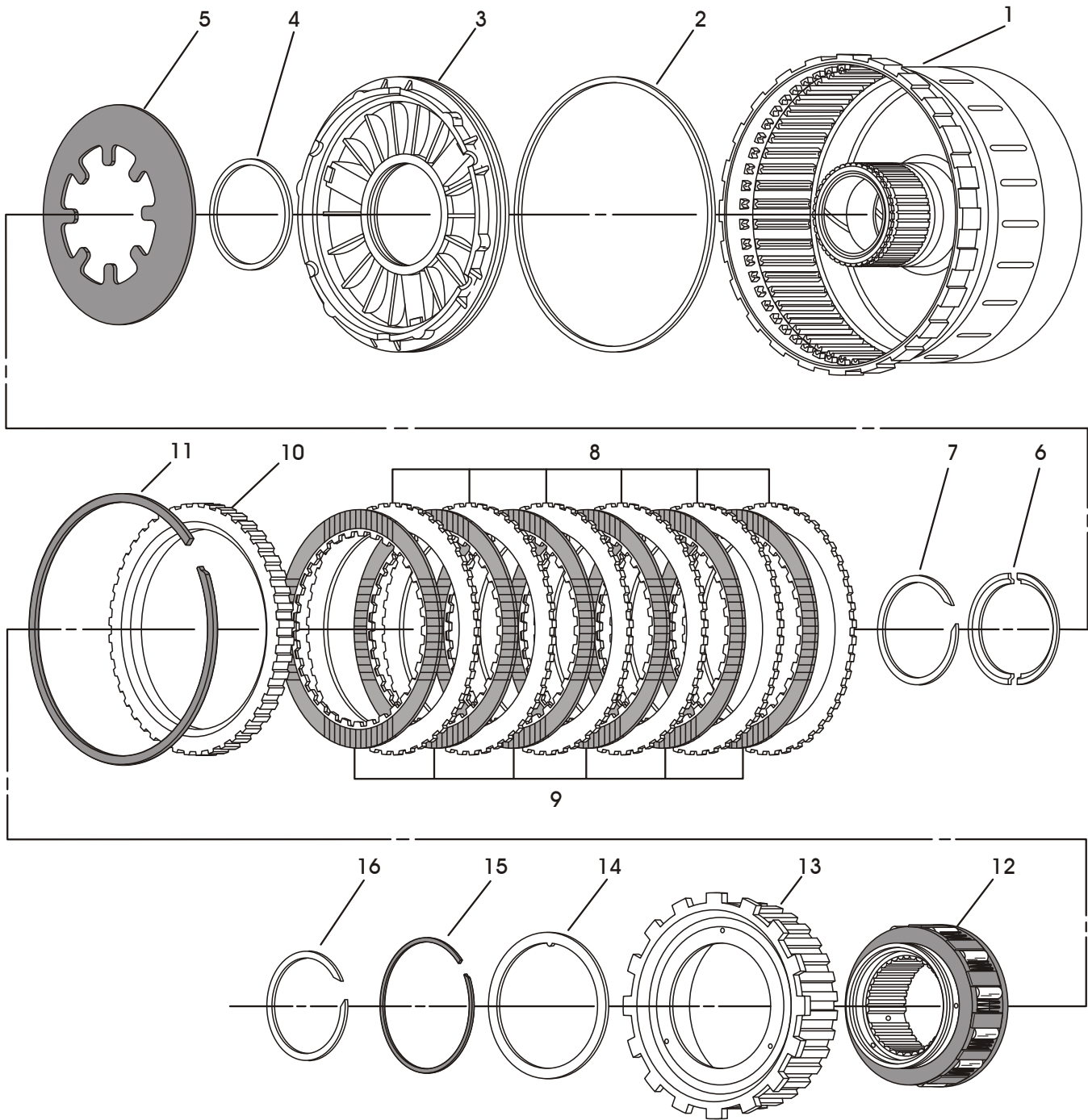

- | | |
|---|--|
| 1. LOW/REVERSE CLUTCH HOUSING | 9. LOW/REVERSE CLUTCH FRICTION PLATES (6 REQUIRED) |
| 2. LOW/REVERSE CLUTCH PISTON OUTER "D" RING | 10. LOW/REVERSE CLUTCH BACKING PLATE |
| 3. LOW/REVERSE CLUTCH PISTON | 11. LOW/REVERSE CLUTCH BACKING PLATE SNAP RING |
| 4. LOW/REVERSE CLUTCH PISTON INNER "D" RING | 12. LOW ROLLER CLUTCH AND INNER RACE ASSEMBLY |
| 5. LOW/REVERSE CLUTCH BELLVILLE PLATE | 13. LOW ROLLER CLUTCH OUTER RACE |
| 6. LOW/REVERSE BELLVILLE PLATE "SPLIT" RETAINING RING | 14. SPACER WASHER |
| 7. LOW ROLLER CLUTCH LOWER SNAP RING | 15. LOW ROLLER INNER RACE RETAINING SNAP RING |
| 8. LOW/REVERSE CLUTCH STEEL PLATES (6 REQUIRED) | 16. LOW ROLLER CLUTCH UPPER SNAP RING |

Copyright © 1999 ATSG

Figure 138

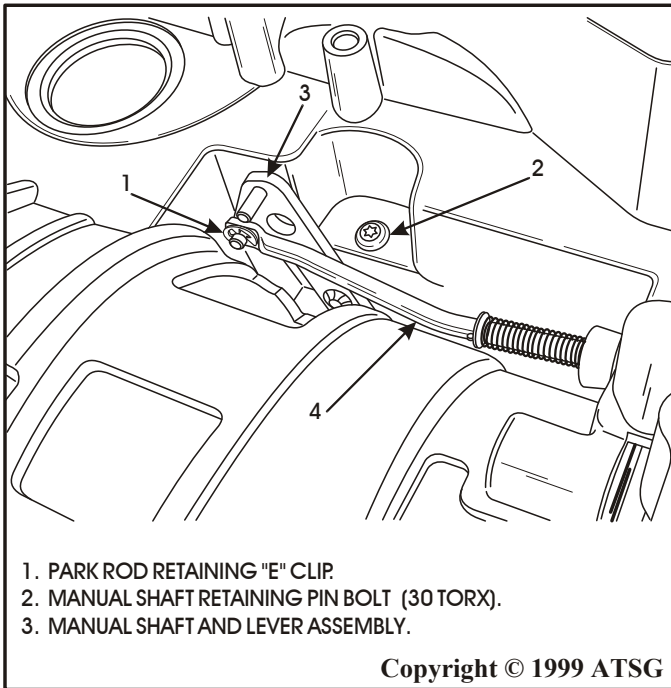

Figure 139

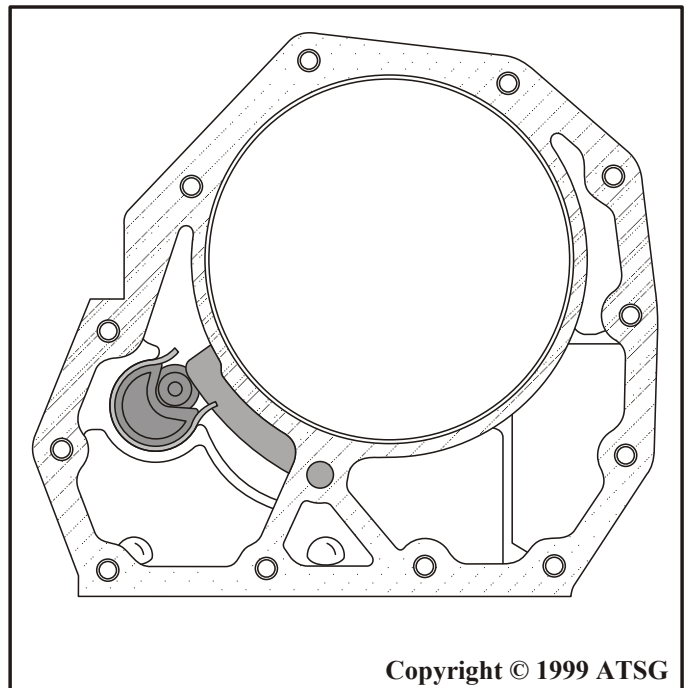

Figure 140

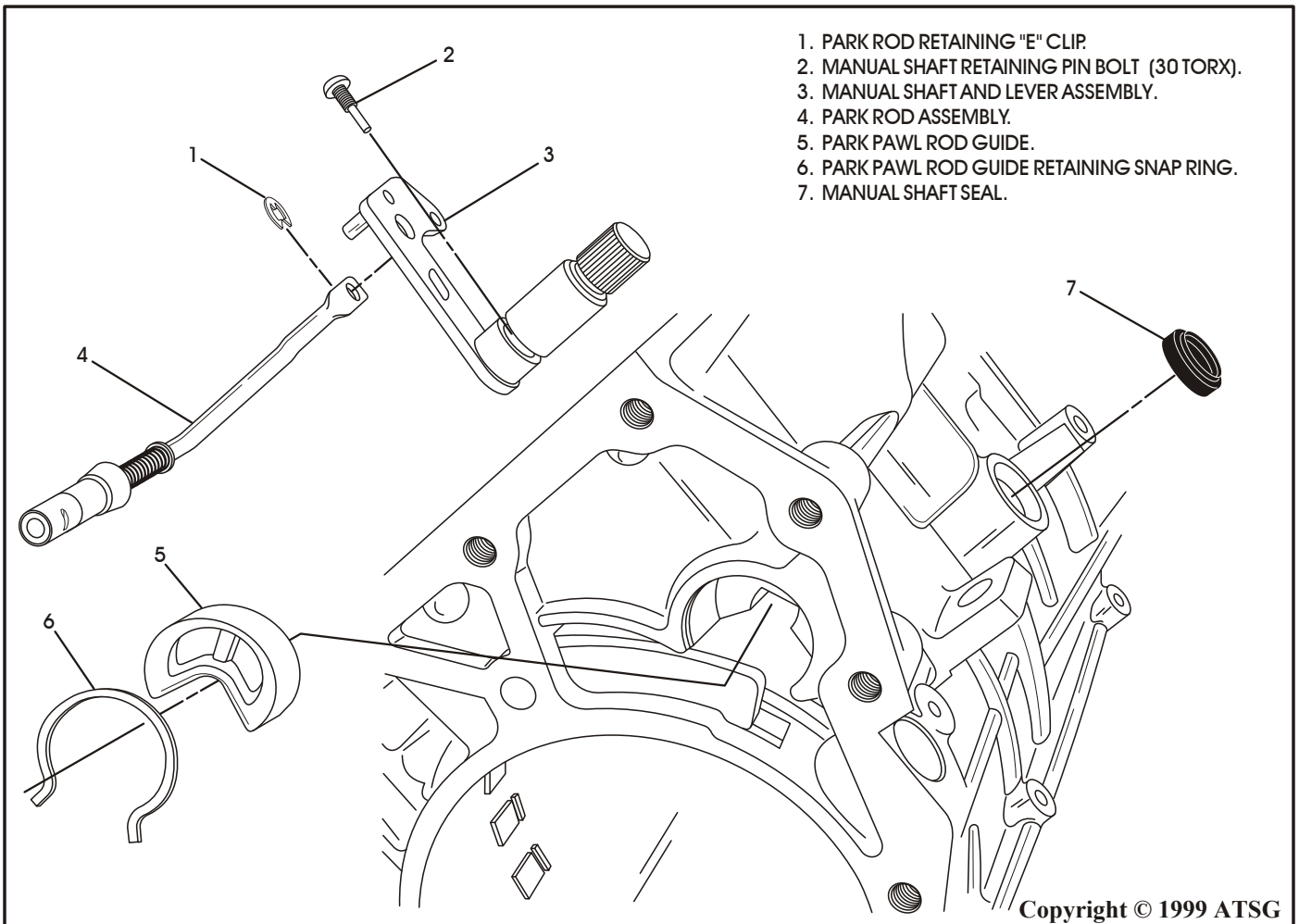
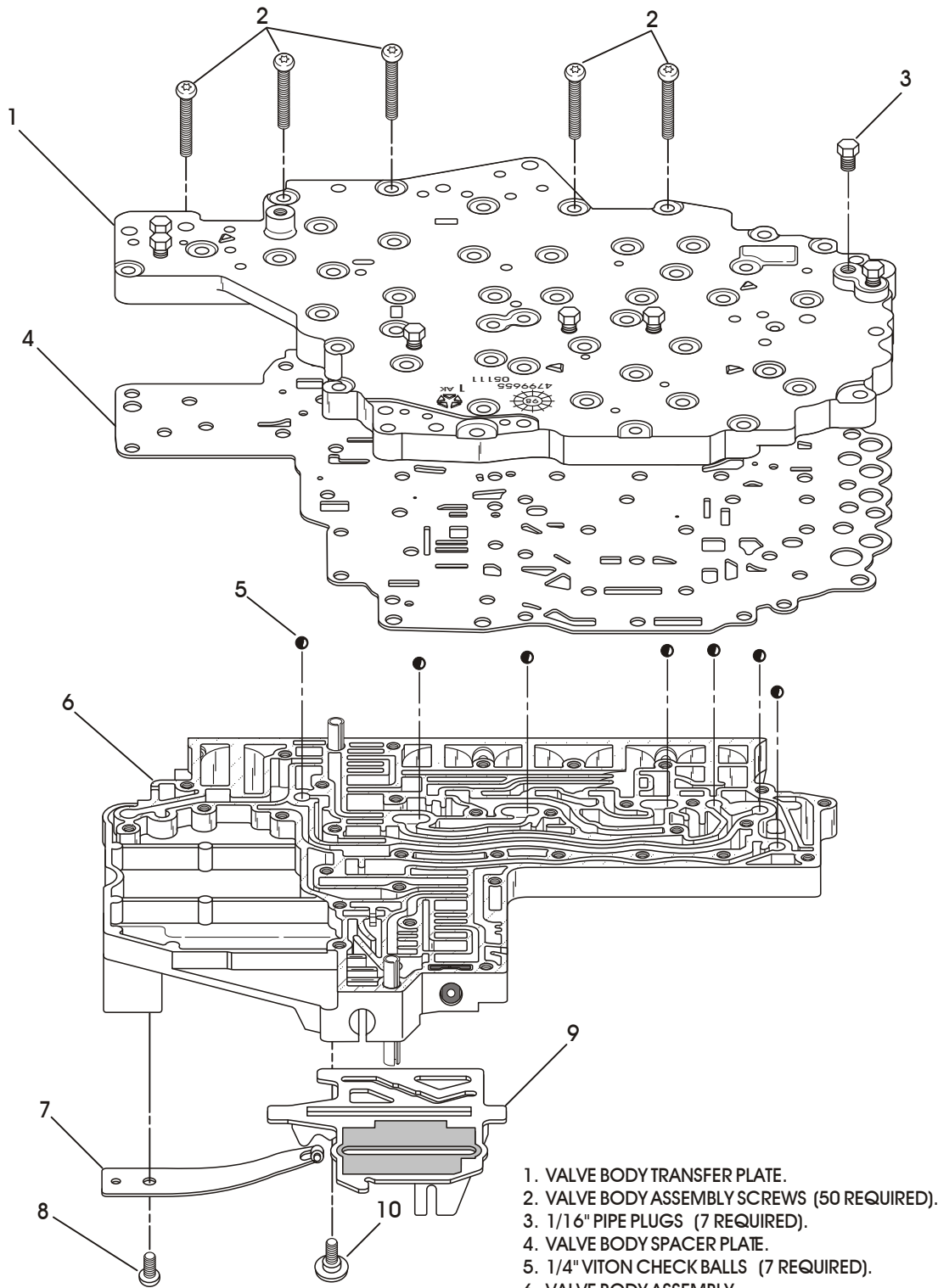

Figure 141

VALVE BODY ASSEMBLY EXPLODED VIEW



1. VALVE BODY TRANSFER PLATE.
2. VALVE BODY ASSEMBLY SCREWS (50 REQUIRED).
3. 1/16" PIPE PLUGS (7 REQUIRED).
4. VALVE BODY SPACER PLATE.
5. 1/4" VITON CHECK BALLS (7 REQUIRED).
6. VALVE BODY ASSEMBLY.
7. MANUAL VALVE DETENT SPRING.
8. MANUAL VALVE DETENT SPRING RETAINING BOLT.
9. TRANSMISSION RANGE SENSOR SELECTOR PLATE.
10. TRS SELECTOR PLATE "SHOULDERED" RETAINING BOLT.

Copyright © 1999 ATSG

Figure 142

MAIN VALVE BODY EXPLODED VIEW

1. MAIN VALVE BODY CASTING.
2. 1/4" VITON CHECKBALLS (7 REQUIRED).
3. SOLENOID SWITCH VALVE LINE-UP
4. SOLENOID SWITCH VALVE LINE-UP PLASTIC RETAINING CLIP
5. MANUAL VALVE.
6. OVERDRIVE CLUTCH ACCUMULATOR PISTON AND SEALS.
7. OVERDRIVE CLUTCH ACCUMULATOR SPRING (SINGLE).
8. UNDERDRIVE CLUTCH ACCUMULATOR PISTON AND SEALS.
9. UNDERDRIVE CLUTCH ACCUMULATOR SPRINGS (DOUBLE).
10. 4TH CLUTCH ACCUMULATOR PISTON AND SEALS.
11. 4TH CLUTCH ACCUMULATOR SPRINGS (DOUBLE).
12. 2ND CLUTCH ACCUMULATOR PISTON AND SEALS.
13. 2ND CLUTCH ACCUMULATOR SPRINGS (DOUBLE).
14. LOW/REVERSE SWITCH VALVE.
15. LOW/REVERSE SWITCH VALVE BORE PLUG.
16. LOW/REVERSE ACCUMULATOR PISTON AND SEALS.
17. LOW/REVERSE ACCUMULATOR SPRINGS (DOUBLE).
18. ACCUMULATOR COVER PLATE.

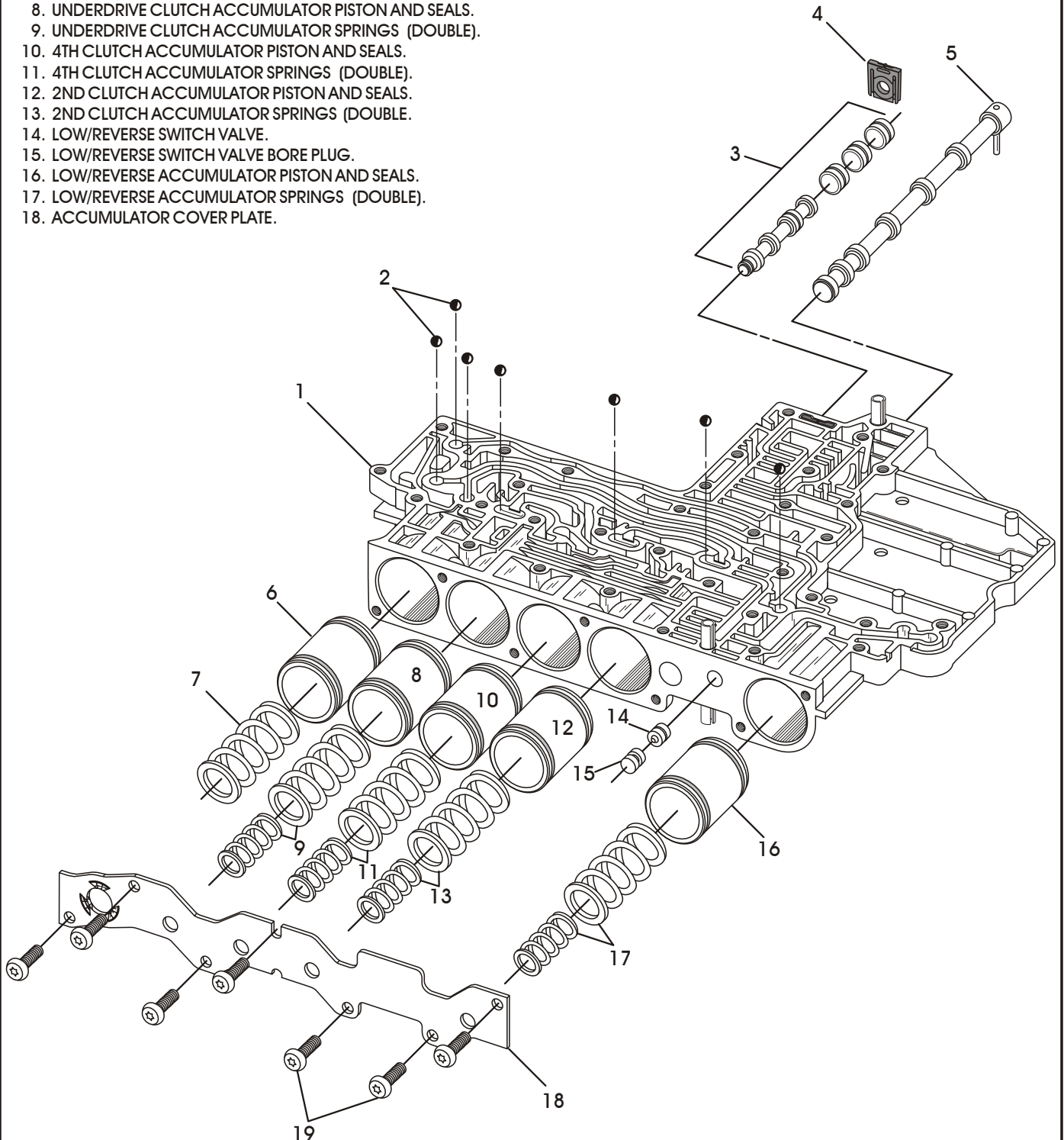

Copyright © 1999 ATSG

Figure 143

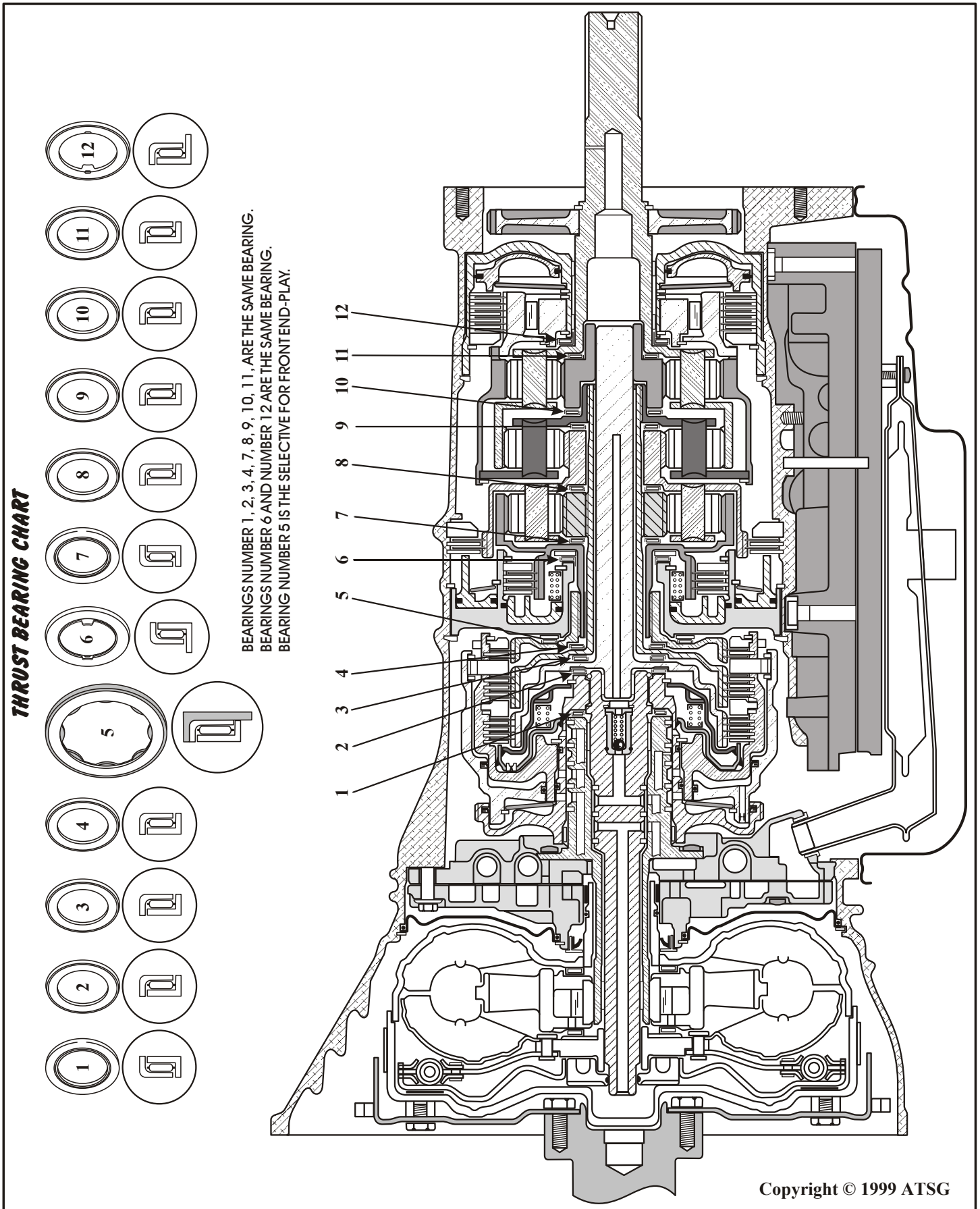

Copyright © 1999 ATSG

Figure 144

45RFE TRANSMISSION SPECIAL TOOLS

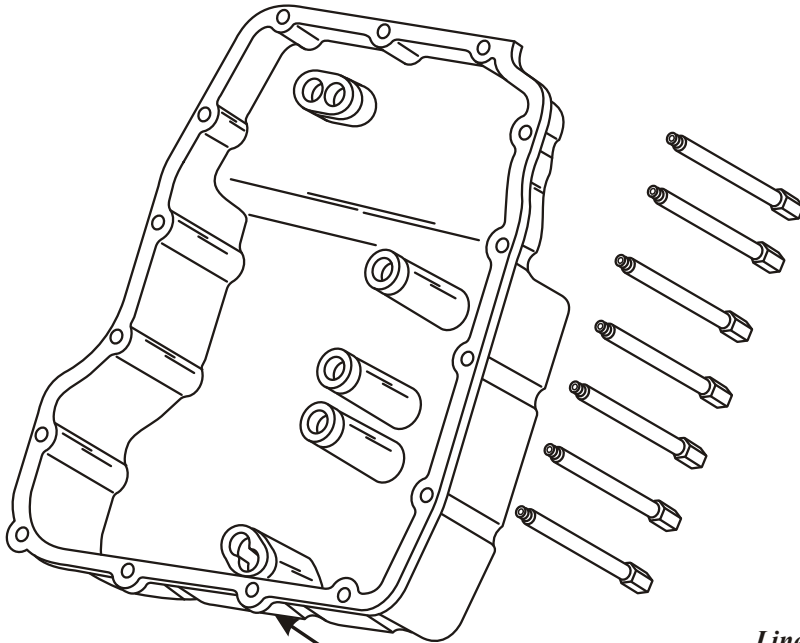

Pressure Tap Adapter Tool No. 8258, to check oil pressures through the valve body taps.

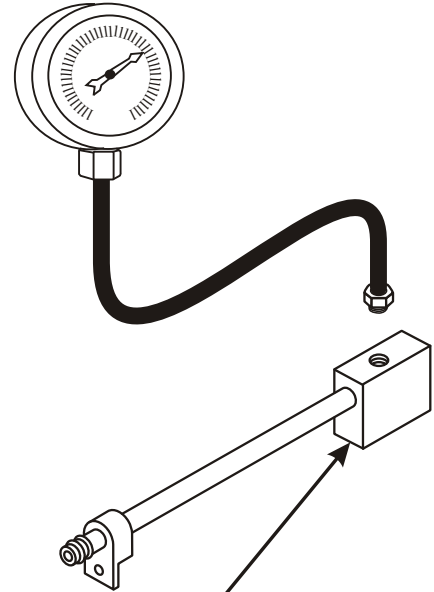

Line Pressure Adapter Tool No. 8259, to install into the line pressure sensor circuit, and then reinstall the sensor and pressure gage.

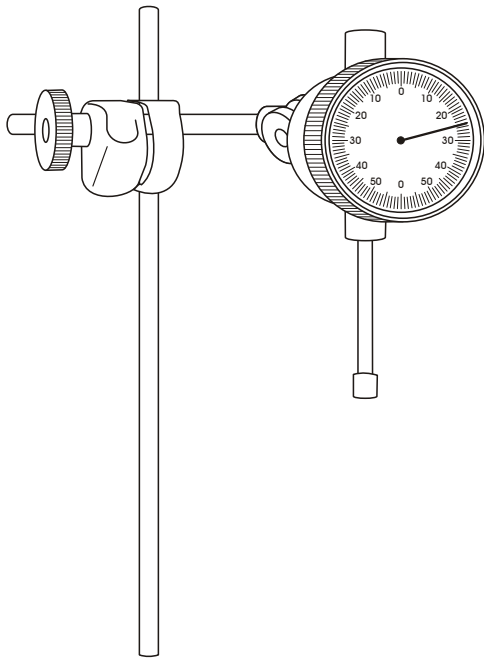

Universal Dial Indicator

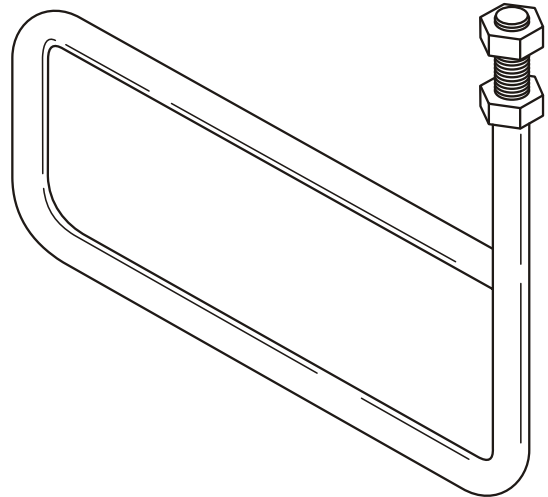

Transmission Case Support Fixture - 8257

Figure 145

45RFE TRANSMISSION SPECIAL TOOLS



*Dipstick Tube
Seal Installer - 8254*

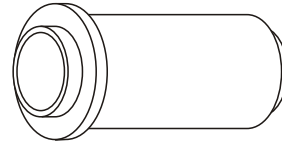

*Oil Pump Seal
Installer - C-3860-A*

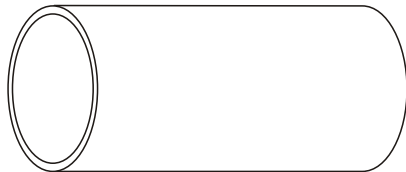

*Front Cover Inner
Sna Ring Installer - 8255*

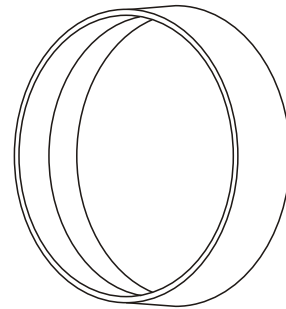

*UD/OD Balance Piston
Seal Protector - 8252*



*Manual Shaft
Seal Installer - 8253*

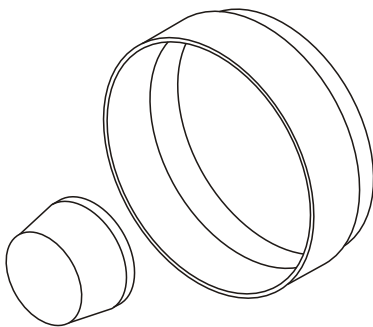

*Input Clutch Piston
Lip Seal Protector - 8504*

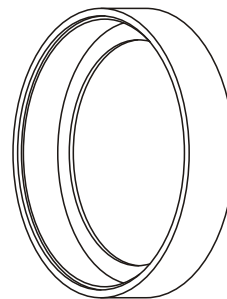

*2nd Clutch Bellville Spring
and Snap Ring Installer - 8249*

Copyright © 1999 ATSG

Figure 146

45RFE TRANSMISSION SPECIAL TOOLS

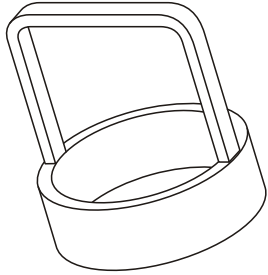

*4th Clutch Piston Return
Spring Compressor - 8250*

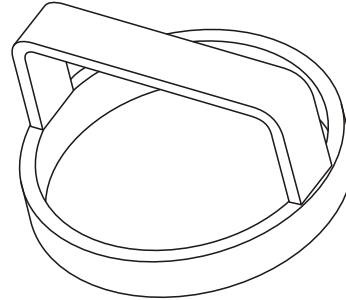

*UD/OD Balance Piston
Spring Compressor - 8251*

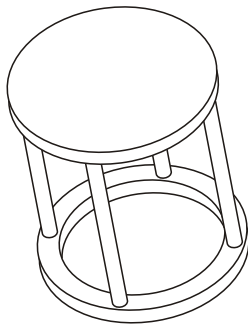

*Low/Reverse Bellville
Spring Compressor - 8285*

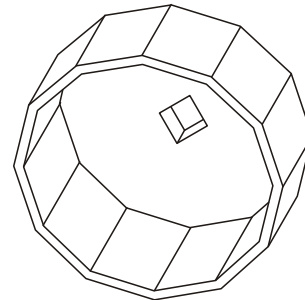

*Cooler Filter
Wrench - 8321*

Figure 147

45RFE IDENTIFICATION TAG LOCATION

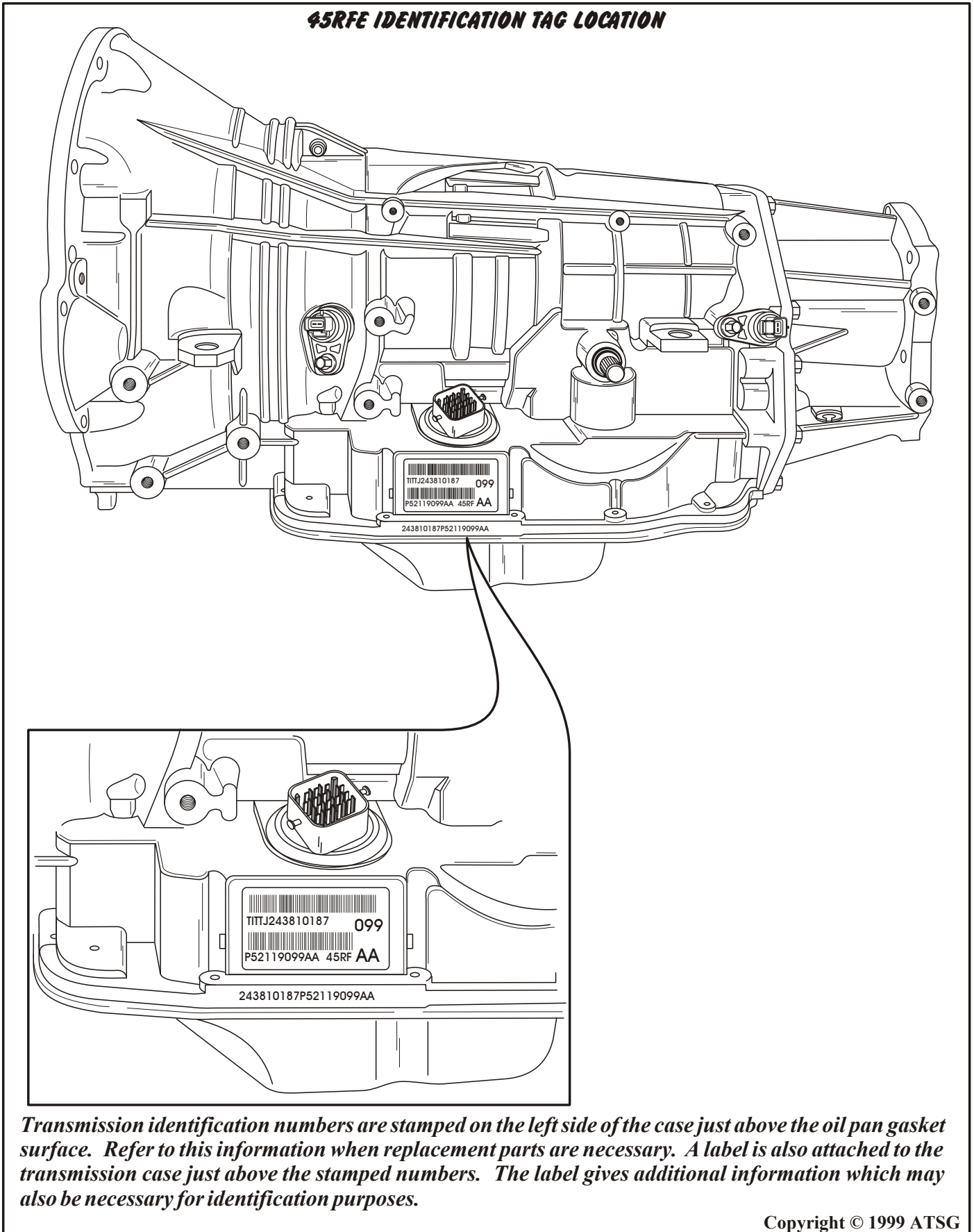

Transmission identification numbers are stamped on the left side of the case just above the oil pan gasket surface. Refer to this information when replacement parts are necessary. A label is also attached to the transmission case just above the stamped numbers. The label gives additional information which may also be necessary for identification purposes.

Copyright © 1999 ATSG

Figure 148